

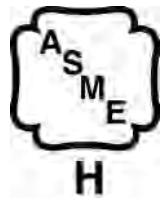
# INSTALLATION, OPERATING AND SERVICE INSTRUCTIONS

## EVA/EVO SERIES BOILER

### INDOOR/OUTDOOR MODULATION



File Number MH25585



For Service and repairs to the heating plant, call your heating contractor. When seeking information on the water heater from the manufacturer, provide water heater model and serial number as shown on rating label.

Water Heater Model	Installation Date	Serial Number	Type System
Heating Contractor			
Address			Phone Number

Your Local Thermal Solutions Representative:



Save this manual for future reference.

---

## IMPORTANT INFORMATION - READ CAREFULLY

---

Post these instructions and maintain in legible condition.

It is critical all personnel read and adhere to all information contained in DANGER, WARNING, and CAUTIONS. All DANGERS, WARNINGS, and CAUTIONS are for reference and guidance purpose, and, therefore, do not substitute for strict adherence to applicable jurisdictional and professional codes and regulations.

All wiring on boilers installed in the USA shall be in accordance with the National Electrical Code and/or local regulations.

All wiring on boilers installed in Canada shall be in accordance with the Canadian Electrical Code and/or local regulations.

**The following terms are used throughout this manual to bring attention to the presence of hazards of various risk levels, or to important information concerning product life.**

Les termes suivants sont utilisés dans tout le manuel pour attirer l'attention sur la présence de risques à différents niveaux ou pour apporter des informations importantes concernant la vie du produit.

### **⚠ DANGER**

**Indicates a hazardous situation** that, if not avoided, will result in death or serious injury.

**Indique une situation dangereuse** qui, si elle n'est pas évitée, entraînera la mort ou des blessures graves.

### **⚠ CAUTION / ATTENTION**

**Indicates a hazardous situation** that, if not avoided, could result in minor or moderate injury.

**Indique une situation dangereuse qui, si elle n'est pas évitée, pourrait entraîner des blessures mineures ou modérées.**

### **⚠ WARNING / AVERTISSEMENT**

**Indicates a hazardous situation** that, if not avoided, could result in death or serious injury.

**Indique une situation dangereuse** qui, si elle n'est pas évitée, pourrait entraîner la mort ou des blessures graves.

### **NOTICE / AVIS**

Indicates special instructions on installation, operation, or maintenance which are important but not related to personal injury hazards.

Indique des instructions particulières relatives à l'installation, au fonctionnement ou à la maintenance, qui sont importantes mais sans rapport avec les risques de blessures corporelles.

### **⚠ DANGER**

**DO NOT store or use gasoline or other flammable vapors or liquids in the vicinity of this or any other appliance. If you smell gas vapors, DO NOT try to operate any appliance - DO NOT touch any electrical switch or use any phone in the building. Immediately, call the gas supplier from a remotely located phone. Follow the gas supplier's instructions or if the supplier is unavailable, contact the fire department.**

NE PAS stocker ou utiliser de l'essence ou autres vapeurs ou liquides inflammables à proximité de cet appareil ou de tout autre appareil. Si vous sentez des vapeurs de gaz, NE PAS essayer de faire fonctionner un quelconque appareil – NE PAS toucher d'interrupteur électrique ou utiliser un quelconque téléphone dans le bâtiment. Appeler immédiatement le fournisseur de gaz à partir d'un téléphone situé à distance. Suivre les instructions du fournisseur de gaz ou si le fournisseur n'est pas disponible, contacter le service d'incendie.

## **▲ WARNING**

**This boiler requires regular maintenance and service to operate safely. Follow the instructions contained in this manual.**

**Improper installation, adjustment, alteration, service or maintenance can cause property damage, personal injury or loss of life. Read and understand the entire manual before attempting installation, start-up operation, or service. Installation and service must be performed only by an experienced, skilled, and knowledgeable installer or service agency**

**This boiler must be properly vented.**

**This boiler needs fresh air for safe operation and must be installed so there are provisions for adequate combustion and ventilation air.**

**The interior of the venting system must be inspected and cleaned before the start of the heating season and should be inspected periodically throughout the heating season for any obstructions. Clean and unobstructed venting and air intake systems are necessary to allow noxious fumes that could cause injury or loss of life to vent safely and will contribute toward maintaining the boiler's efficiency.**

**This boiler is supplied with safety devices which may cause the boiler to shut down and not re-start without service. If damage due to frozen pipes is a possibility, the heating system should not be left unattended in cold weather; or appropriate safeguards and alarms should be installed on the heating system to prevent damage if the boiler is inoperative.**

**This boiler contains very hot water under high pressure. Do not unscrew any pipe fittings nor attempt to disconnect any components of this boiler without positively assuring the water is cool and has no pressure. Always wear protective clothing and equipment when installing, starting up or servicing this boiler to prevent scald injuries. Do not rely on the pressure and temperature gauges to determine the temperature and pressure of the boiler. This boiler contains components which become very hot when the boiler is operating. Do not touch any components unless they are cool.**

**Boiler materials of construction, products of combustion and the fuel contain alumina, silica, heavy metals, carbon monoxide, nitrogen oxides, aldehydes and/or other toxic or harmful substances which can cause death or serious injury and which are known to the state of California to cause cancer, birth defects and other reproductive harm. Always use proper safety clothing, respirators and equipment when servicing or working nearby the appliance.**

**Failure to follow all instructions in the proper order can cause personal injury or death. Read all instructions, including all those contained in component manufacturers manuals which are provided with the boiler before installing, starting up, operating, maintaining or servicing.**

**Keep boiler area clear and free from combustible materials, gasoline and other flammable vapors or liquids.**

**All cover plates, enclosures and guards must be in place at all times.**

**This product must be installed by a licensed plumber or gas fitter when installed within the Commonwealth of Massachusetts.**

## **NOTICE / AVIS**

**This boiler has a limited warranty, a copy of which is printed on the back of this manual. It is the responsibility of the installing contractor to see that all controls are correctly installed and are operating properly when the installation is complete.**

## ⚠ AVERTISSEMENT

Cette chaudière exige un entretien et une maintenance régulière pour un fonctionnement sûr. Suivre les instructions contenues dans ce manuel.

Une installation, un réglage, une dégradation, un entretien ou une maintenance incorrecte peuvent causer des dommages matériels, des blessures corporelles ou une perte de vie. Lire et comprendre la totalité du manuel avant d'essayer d'installer, de démarrer la mise en exploitation ou de réaliser des entretiens. L'installation et l'entretien doivent n'être réalisés que par un installateur expérimenté, qualifié ou une agence d'entretien.

Cette chaudière doit être correctement ventilée.

Cette chaudière nécessite de l'air frais pour un fonctionnement sûr et elle doit être installée de façon à ce qu'il existe des conditions pour une ventilation d'air et une combustion appropriées.

L'intérieur du système de ventilation doit être inspecté et nettoyé avant le démarrage de la saison de chauffe et devra être inspecté périodiquement tout au long de la saison de chauffe à la recherche de toute obstruction. Des systèmes de ventilation et d'admission d'air dégagés et propres sont nécessaires pour permettre aux fumées toxiques, qui pourraient conduire à des blessures corporelles ou pertes de vies, d'être ventilées de façon sûre et vont contribuer à un maintien de l'efficacité de l'appareil.

Cet appareil est fourni avec des dispositifs de sécurité qui peuvent conduire à l'arrêt de l'appareil et à ne pas pouvoir redémarrer sans avoir recours à une intervention. Si des dommages dus à des tuyaux gelés sont une possibilité, le système de chauffage ne devra pas être laissé sans surveillance par temps froid ; sinon des alarmes ou dispositifs de protections devront être installés sur le système de chauffage afin d'empêcher tout dommage si la chaudière est inopérante.

Cette chaudière contient de l'eau très chaude sous haute pression. Ne pas dévisser de raccords de tuyauterie, ni d'essayer de déconnecter tout composant de cette chaudière sans s'assurer formellement que l'eau est refroidie et n'est plus sous pression. Porter toujours un équipement et des vêtements de protection lors de l'installation, de la mise en service ou de l'entretien de cette chaudière afin d'empêcher toute blessure par brûlure. Ne pas se fier aux jauges de pression et de température pour déterminer la température et la pression de la chaudière. Cette chaudière contient des composants qui deviennent très chauds lors de son fonctionnement. Ne toucher aucun de ces composants à moins qu'ils ne soient refroidis.

Les matériaux de construction de la chaudière, les produits de combustion et le combustible contiennent de l'alumine, de la silice, des métaux lourds, du monoxyde de carbone, des oxydes d'azote, des aldéhydes et/ou autres substances nocives ou toxiques qui peuvent causer la mort ou conduire à des blessures sérieuses ; ceux-ci sont connus par l'état de Californie pour causer des cancers, des malformations à la naissance et autres dommages au fœtus. Porter toujours des vêtements de sécurité adaptés, des respirateurs et un équipement lors de l'entretien ou de tout travail à proximité de l'appareil.

Le fait de ne pas suivre toutes les instructions dans le bon ordre peut causer des blessures corporelles ou la mort. Lire toutes les instructions, incluant toutes celles contenues dans les manuels des fabricants de composants fournis avec la chaudière avant d'installer, de mettre en service, de faire fonctionner, de réaliser la maintenance ou l'entretien.

Maintenir la zone de la chaudière dégagée et à l'écart de matières combustibles, d'essence et autres vapeurs ou liquides inflammables.

Toutes les plaques de recouvrement, boîtiers et protections doivent être en place à tout moment.

Ce produit doit être installé par un plombier agréé ou un monteur d'installation au gaz lors de toute installation dans le Commonwealth du Massachusetts.

## AVIS

Cette chaudière a une garantie limitée, une copie de celle-ci est imprimée au verso de ce manuel. Il est de la responsabilité de l'entreprise d'installation de vérifier que toutes les commandes sont correctement installées et fonctionnent adéquatement lorsque l'installation est achevée.

## Table of Contents

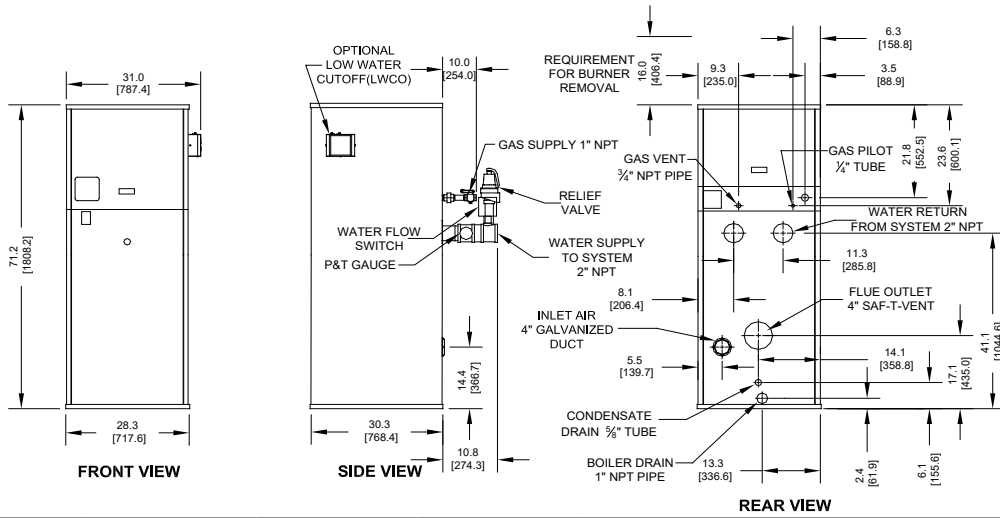
<b>I. Pre-Installation</b>	<b>10</b>	<b>VII. Modular Systems</b>	<b>34</b>
A. General	10	A. MODULAR SYSTEMS	34
B. NFPA guidelines	10	B. CONDENSATE DRAINS	41
<b>II. Unpack the Boiler</b>	<b>12</b>	<b>VIII. System Start-up</b>	<b>42</b>
A. Unpacking	12	A. System Checks	42
<b>III. Venting</b>	<b>13</b>	B. Flame Safeguard Operation Check	43
A. General Venting Requirements	13	C. Commissioning the Boiler	44
B. Positive Pressure Venting Requirements	15	D. Finish Commissioning the Boiler	44
C. Negative Pressure Venting Requirements	15	E. Water Treatment	44
D. General Guidelines	15	<b>IX. Boiler Operational Sequence</b>	<b>47</b>
E. IMPORTANT	18	<b>X. Service/Maintenance</b>	<b>48</b>
F. COMBUSTION AIR	20	A. Safety Controls, Operation, and Shut Down	50
<b>IV. Water</b>	<b>22</b>	B. Troubleshooting Guide	51
A. WATER TREATMENT	22	C. Periodic Maintenance/Service List	53
B. WATER PIPING AND TRIM	23	D. Inspection and Cleaning Procedures	54
<b>V. Gas Piping</b>	<b>26</b>	<b>XI. Repair Parts</b>	<b>55</b>
A. Gas Piping	26	<b>XII. Temperature Controller Operation</b>	<b>75</b>
<b>VI. Electrical</b>	<b>30</b>	A. Description	75
A. ELECTRICAL	30	B. Set-Up	75
		C. Adjustments	76
		D. Other	76
		<b>Warranty</b>	<b>80</b>

Clearances to Combustible Materials (in.)					
Left Side	Right Side	Front	Rear	Top	Flue Connector
6	6	24	6	6	18
Recommended Clearances for Service					
Model Size	Left	Right	Front*	Rear*	Top
500	24	24	24	24	16
750	24	24	24	24	16
1000	24	24	24	24	16
1500	24	24	24	24	19
2000	24	24	24	24	31
2000s	24	24	36	36	13
2500	24	24	36	36	20
3000	24	24	36	36	26.5
* When 3 or more units are mounted side-by-side, front service clearance increases by 12" and the rear service clearance increases by 24".					
<b>NOTE: Verify clearances with local codes</b>					

### Net AHRI Ratings

- The Net AHRI Water Ratings shown are based on a piping and pickup allowance of 1.15.
- Max input ratings are based on 0-2000 ft elevation. Reduce gas input four percent (4%) for each additional 1000 feet above sea level.
- The manufacturer should be consulted before selecting a boiler for installations having unusual piping and pickup requirements, such as intermittent system operation, extensive piping systems, etc.
- The ratings have been determined under the provisions governing forced draft boiler-burner units.

EVA-500



- Notes:**
1. Piping removed for visual clarity (rear view).
  2. See notes concerning Net AHRI Ratings on page 4.

BOILER MODEL NUMBER	AHRI CERTIFIED www.ahridirectory.org			CAPACITIES		
	INPUT (MBH)	GROSS OUTPUT (MBH)	NET AHRI RATING (MBH) <sup>2</sup>	WATER VOLUME (gallons)	DRY WEIGHT (lbs.)	WET WEIGHT (lbs.)
EVA-500	500	431	375	6.1	772	823
EVA-750	750	638	555	15.9	1,097	1,230

BOILER MODEL RANGE	ELECTRICAL		
	SUPPLY (volts/Hz/phase)	Blower Motor (hp)	Nominal power draw (amps)
EVA-500	120/60/1	1/2	4.5
	208/60/1		3.5
	230/60/1		3.4
	208/60/3		3.0
	230/60/3		2.9
	460/60/3		1.5
EVA-750	120/60/1	1-1/2	7.5
	208/60/1		6.6
	230/60/1		6.4
	208/60/3		6.0
	230/60/3		6.0
	460/60/3		3.0

EVA-750

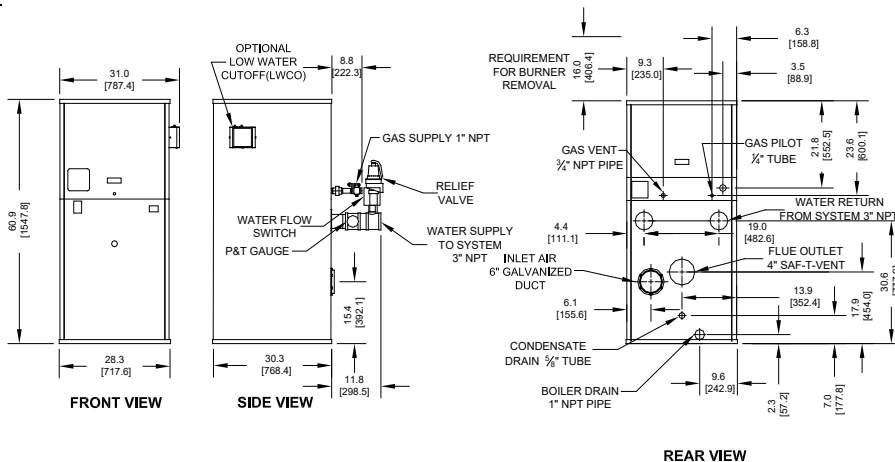
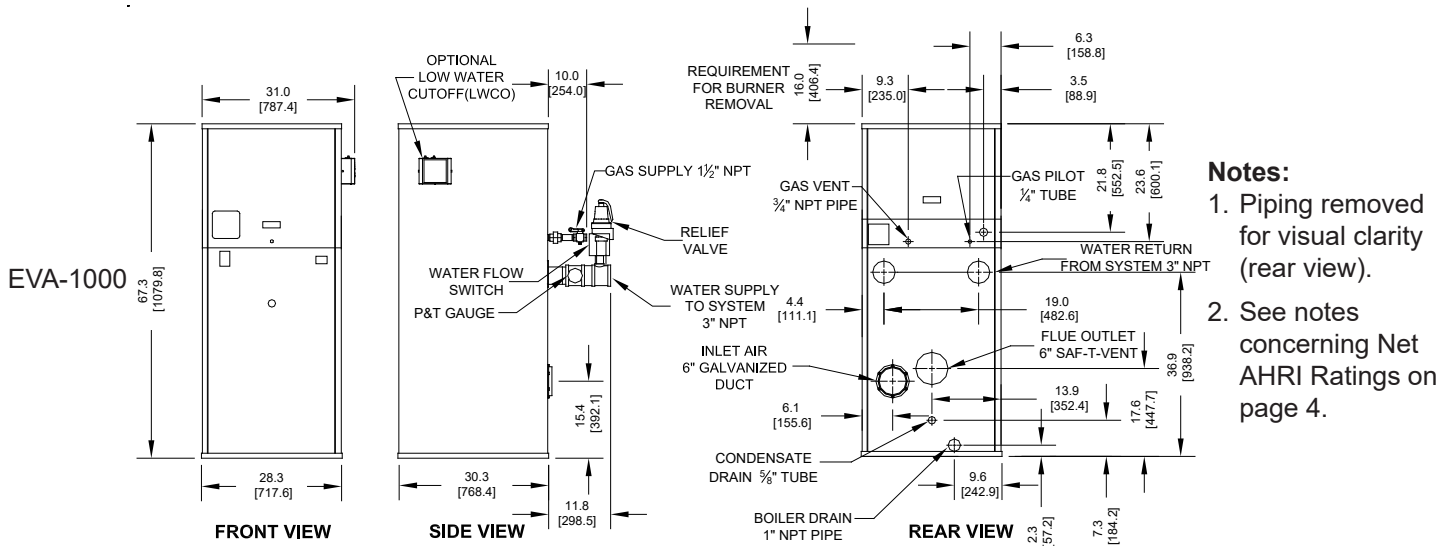
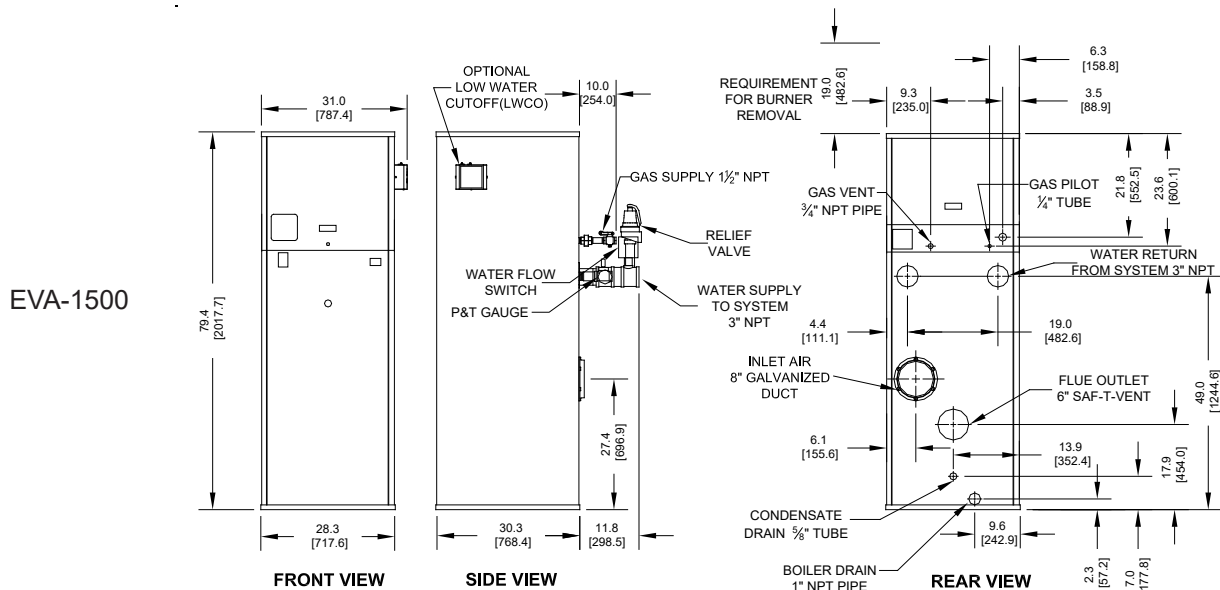


Figure 1a: Dimensions and capacities EVA 500 & 750



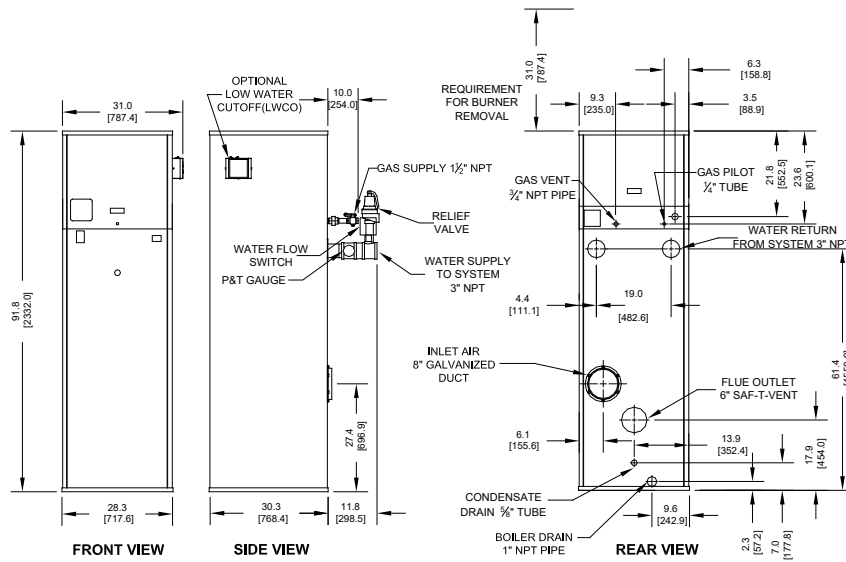
BOILER MODEL NUMBER	AHRI CERTIFIED® www.ahridirectory.org			CAPACITIES		
	INPUT (MBH)	GROSS OUTPUT (MBH)	NET AHRI RATING (MBH) <sup>2</sup>	WATER VOLUME (gallons)	DRY WEIGHT (lbs.)	WET WEIGHT (lbs.)
EVA-1000	1,000	850	739	16.4	1,185	1,322
EVA-1500	1,500	1,275	1,109	17.4	1,327	1,472

BOILER MODEL RANGE	ELECTRICAL		
	SUPPLY (volts/Hz/phase)	Blower Motor (hp)	Nominal power draw (amps)
EVA-1000/1500	120/60/1	1-1/2	7.5
	208/60/1		6.6
	230/60/1		6.4
	208/60/3		6.0
	230/60/3		6.0
	460/60/3		3.0




**Figure 1b: Dimensions and capacities EVA 1000 & 1500**

EVA-2000



- Notes:**
1. Piping removed for visual clarity (rear view).
  2. See notes concerning Net AHRI Ratings on page 4.

BOILER MODEL NUMBER				CAPACITIES		
	INPUT (MBH)	GROSS OUTPUT (MBH)	NET AHRI RATING (MBH) <sup>2</sup>	WATER VOLUME (gallons)	DRY WEIGHT (lbs.)	WET WEIGHT (lbs.)
EVA-2000	2,000	1,696	1,475	18.5	1,461	1,615
EVA-2000S	2,000	1,732	1,506	40.1	1,835	2,169

BOILER MODEL RANGE	ELECTRICAL		
	SUPPLY (volts/Hz/phase)	Blower Motor (hp)	Nominal power draw (amps)
EVA-2000/2000S	120/60/1	1-1/2	7.5
	208/60/1		6.6
	230/60/1		6.4
	208/60/3		6.0
	230/60/3		6.0
	460/60/3		3.0

EVA-2000S \* (no on/off option)

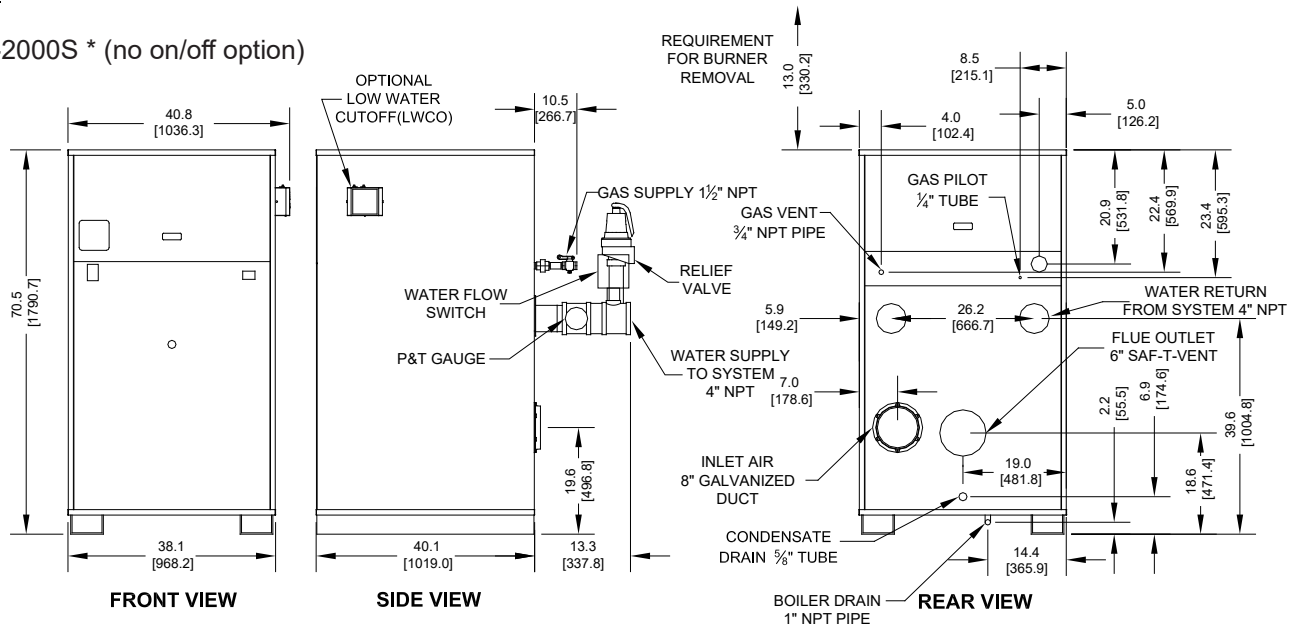
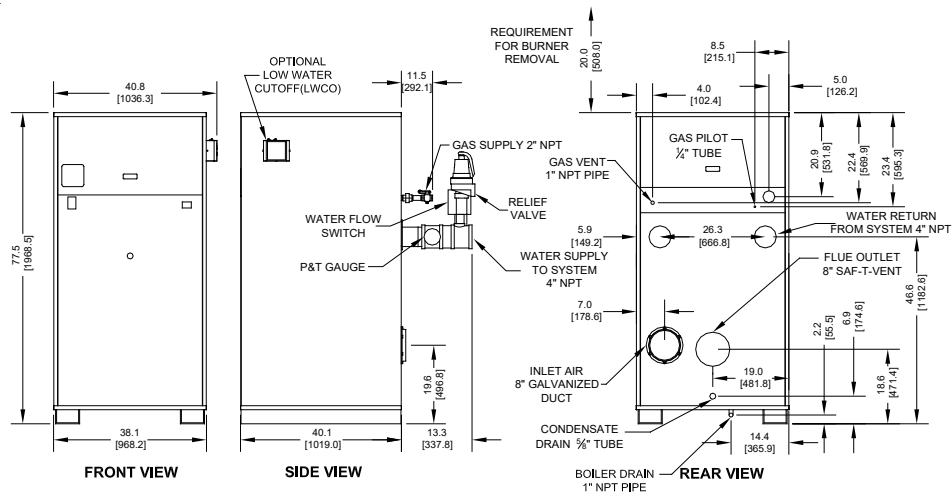


Figure 1c: Dimensions and capacities EVA 2000 & 2000S

EVA-2500



- Notes:**
1. Piping removed for visual clarity (rear view).
  2. See notes concerning Net AHRI Ratings on page 4.

BOILER MODEL NUMBER	AHRI CERTIFIED® www.ahridirectory.org			CAPACITIES		
	INPUT (MBH)	GROSS OUTPUT (MBH)	NET AHRI RATING (MBH) <sup>2</sup>	WATER VOLUME (gallons)	DRY WEIGHT (lbs.)	WET WEIGHT (lbs.)
EVA-2500	2,500	2,170	1,887	41.6	2,052	2,399
EVA-3000	3,000	2,610	2,270	43.1	2,193	2,552

BOILER MODEL RANGE	ELECTRICAL		
	SUPPLY (volts/Hz/phase)	Blower Motor (hp)	Nominal power draw (amps)
EVA-2500	208/60/1	1-1/2	8.0
	230/60/1		7.8
	208/60/3		7.4
	230/60/3		7.3
	460/60/3		3.7
EVA-3000	208/60/1	2	8.0
	230/60/1		7.8
	208/60/3		7.4
	230/60/3		7.3
	460/60/3		3.7

EVA-3000

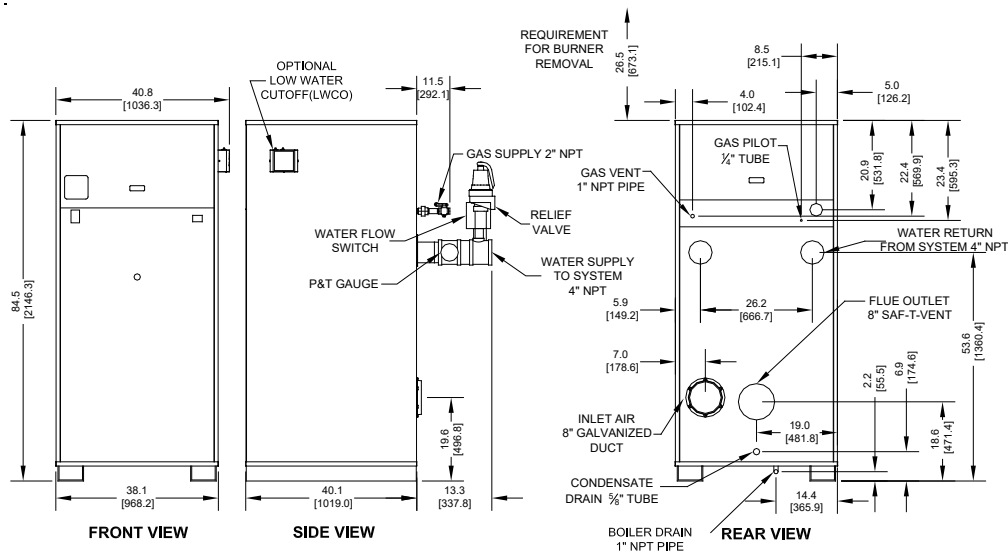


Figure 1d: Dimensions and capacities EVA 2500 & 3000

## I. Pre-Installation

### ⚠ WARNING / AVERTISSEMENT

**Carefully read all instructions before installing boiler. Failure to follow all instructions in proper order can cause personal injury or death.**

Lire avec attention toutes les instructions avant d'installer la chaudière. Le fait de ne pas suivre toutes les instructions dans le bon ordre peut causer des blessures corporelles ou la mort

### ⚠ WARNING / AVERTISSEMENT

**Adequate combustion and ventilation air must be provided to assure proper combustion.**

Une combustion et une ventilation d'air adéquates doivent être fournies pour assurer une combustion correcte.

#### A. General

1. Installation must conform to the requirements of the authority having jurisdiction. In the absence of such requirements, installation must conform to the *National Fuel Gas Code*, NFPA 54/ANSI Z223.1, and/or CAN/CSA B149 Installation Codes. Where required by the authority having jurisdiction, the installation must conform to the *Standard for Controls and Safety Devices for Automatically Fired Boilers*, ANSI/ASME CSD-1.
2. The boiler is not design certified for installation on combustible flooring. The boiler must not be installed on carpeting.
3. Provide clearance between boiler jacket and combustible material in accordance with local fire ordinance. Refer to page 4 of this manual for minimum listed clearance from combustible material.
4. Install on level floor. For basement installation provide concrete base if floor is not perfectly level or if water may be encountered on floor around boiler. Floor must be able to support weight of boiler, water and all additional system components.
5. Protect gas ignition system components from water (dripping, spraying, rain, etc.) during boiler operation and service (circulator replacement, condensate trap service, control replacement, etc.).
6. Provide combustion and ventilation air in accordance with applicable provisions of local building codes or: USA - *National Fuel Gas Code*, NFPA 54/ANSI Z223.1, Section 5.3, Air for Combustion and Ventilation; Canada - Natural Gas Installation Code, CAN/CSA - B149.1, or Propane Installation Code, CAN/CSA - B.149.2, Part 5, Venting Systems and Air Supply for Appliances.

#### B. NFPA guidelines

The following guideline is based on the *National Fuel Gas Code*, NFPA 54/ANSI Z223.1.

1. Determine volume of space (boiler room). Rooms communicating directly with space (through openings not furnished with doors) are considered part of space.
2. Volume [ft<sup>3</sup>] = Length [ft] x Width [ft] x Height [ft]
3. Determine Total Input of all appliances in space. Round result to nearest 1,000 Btu per hour (Btuh).
4. Determine type of space. Divide Volume by Total Input.
  - a. If result is greater than or equal to 50 ft<sup>3</sup> per 1,000 Btuh, space is considered an *unconfined space*.
  - b. If result is less than 50 ft<sup>3</sup> per 1,000 Btuh, space is considered a *confined space*.
5. Determine building type. A building of *unusually tight construction* has the following characteristics:
  - a. Walls and ceiling exposed to outside atmosphere have a continuous water vapor retarder with a rating of 1 perm or less with openings gasketed and sealed, and;
  - b. Weather-stripping has been added on openable windows and doors, and;
  - c. Caulking or sealants applied in joints around window and door frames, between sole plates and floors, between wall-ceiling joints, between wall panels, at plumbing and electrical penetrations, and at other openings.
6. For boiler located in an *unconfined space in a building of other than unusually tight construction*, adequate combustion and ventilation air is normally provided by fresh air infiltration through cracks around windows and doors.

### NOTICE / AVIS

**Boilers operated with sealed combustion are exempt from needing provisions for combustion air from the room, provided air intake piping is installed per code and the instructions in this manual.**

Les chaudières fonctionnant avec une combustion hermétique n'ont pas besoin de disposition spécifique pour l'air de combustion de la pièce, sous réserve que le conduit d'air d'admission ait été installé selon le code et les instructions dans ce manuel.

7. For boiler located within *unconfined space in building of unusually tight construction* or within *confined space*, provide outdoor air through two permanent openings which communicate directly or by duct with the outdoors or spaces (crawl or attic) freely communicating with the outdoors. Locate one opening within 12 inches of top of space. Locate remaining opening within 12 inches of bottom of space. Minimum dimension of air opening is 3 inches. Size each opening per the following:
  - a. Direct communication with outdoors. Minimum free area of 1 square inch per 4,000 Btu per hour input of all equipment in space.
  - b. Vertical ducts. Minimum free area of 1 square inch per 4,000 Btu per hour input of all equipment in space. Duct cross-sectional area shall be same as opening free area.
  - c. Horizontal ducts. Minimum free area of 1 square inch per 2,000 Btu per hour input of all equipment in space. Duct cross-sectional area shall be same as opening free area.
8. Alternate method for boiler located within confined space. Use indoor air if two permanent openings communicate directly with additional space(s) of sufficient volume such that combined volume of all spaces meet criteria for unconfined space. Size each opening for minimum free area of 1 square inch per 1,000 Btu per hour input of all equipment in spaces, but not less than 100 square inches.
9. Ventilation Duct Louvers and Grilles. Equip outside openings with louvers to prevent entrance of rain and snow, and screens to prevent entrance of insects and rodents. Louvers and grilles must be fixed in open position or interlocked with equipment to open automatically before burner operation. Screens must not be smaller than ¼ inch mesh.
10. Consider the blocking effect of louvers, grilles and screens when calculating the opening size to provide the required free area. If free area of louver or grille is not known, assume wood louvers have 20-25 percent free area and metal louvers and grilles have 60-75 percent free area.

#### NOTICE

**For installation and operation where the ambient temperature will not be less than 32 °F (0 °C).**

#### **⚠ DANGER**

**Do not install boiler where gasoline or other flammable vapors or liquids, or sources of hydrocarbons (i.e. bleaches, cleaners, chemicals, sprays, paint removers, fabric softeners, etc.) are used or stored.**

Ne pas installer la chaudière là où de l'essence ou autres vapeurs ou liquides inflammables, ou des sources d'hydrocarbures (par exemple blanchisseurs, produits de nettoyage, produits chimiques, vaporisateurs, décapants pour peintures, adoucisseurs de tissus, etc.) sont utilisés ou stockés.

#### NOTICE / AVIS

**Due to the low water content of the boiler, incorrect sizing of the boiler with regard to the heating system load will result in excessive boiler cycling and accelerated component failure. Thermal Solutions DOES NOT warrant failures caused by incorrectly sized boiler applications. DO NOT oversize the boiler to the system. Modular boilers greatly reduce the likelihood of boiler oversizing.**

Étant donné le faible contenu d'eau dans la chaudière, un dimensionnement incorrect de la chaudière vis-à-vis de la charge du système de chauffage va résulter en des cycles excessifs de la chaudière et accélérer la défaillance des composants. Thermal Solutions NE garantit PAS les défaillances dues à des applications incorrectement dimensionnées de la chaudière. NE PAS surdimensionner la chaudière par rapport au système. Les chaudières modulaires réduisent grandement la probabilité de surdimensionnement de chaudière.

#### **⚠ WARNING**

**Carbon monoxide is an odorless, deadly gas that may be introduced into the building by any malfunctioning fuel burning product or vent system failure. The installer must verify that at least one carbon monoxide alarm has been installed within a residential living space or home following the alarm manufacturer's instructions and applicable local codes before putting the appliance into operation. Consider installing CO alarms in boiler room and all potential living spaces to warn occupants in a case of CO exposure.**

## II. Unpack the Boiler

### NOTICE / AVIS

**Boiler crate is equipped with a tip and tell label. If label indicates boiler has been tipped over during shipping, remove crate and inspect before trucker leaves.**

La caisse de la Chaudière est équipée d'une étiquette hautbas. Si l'étiquette indique que la chaudière a été retournée lors de l'expédition, retirer la caisse et faire une inspection avant que le camionneur ne s'en aille.

### ⚠ WARNING / AVERTISSEMENT

**Installation of this boiler should be undertaken only by trained and skilled personnel from a qualified service agency.**

L'installation de cette chaudière devra être entreprise par un personnel formé et spécialisé d'une agence de services qualifiée.

### ⚠ CAUTION / ATTENTION

**Do not drop boiler. Do not bump boiler jacket against floor.**

Ne pas faire tomber la chaudière. Ne pas cogner l'enveloppe de la chaudière contre le sol.

### NOTICE

**For installation and operation where the ambient temperature will not be less than 32 °F (0 °C).**

**For outdoor installation only: Do not install this boiler under an overhang less than 3 feet from its top. The area under the overhang must be open on 3 sides. Installer à l'extérieur seulement.»**

**Ne pas installer ce chauffe-eau sous une saillie mesurant moins de 3 pi de hauteur. La partie sous la saillie doit être couverte sur 3 côtés.**

### A. Unpacking

1. Move boiler to approximate installed position.
2. Remove all crate fasteners.
3. Open outside container and remove all inside protective spacers and bracing.
4. Remove all boiler hold-down fasteners. Remove unit from shipping skid (if provided).
  - a. Tilt the boiler to one side and slide a small roller under the raised base.
  - b. Tilt the boiler to the other side and slide another roller under the base.
  - c. Place a larger pipe roller on floor behind the skid.
  - d. Roll the boiler forward or backward off the skid and onto the pipe roller.
5. Move boiler to its permanent location.

## III. Venting

### **⚠ WARNING**

**Improper venting may result in property damage and the release of flue gasses which contain deadly carbon monoxide (CO) into the building, which can cause severe personal injury and/or death.**

#### **A. General Venting Requirements**

1. In order to properly vent this boiler, the installer must select and install a vent system that meets all requirements specified in this section (VENTING) as well as following the instructions provided by the vent system manufacturer.
2. The vent system shall be designed and constructed in accordance with the National Fuel Gas Code/ NFPA 54 ANSI Z223.1 and applicable local building codes to develop a positive flow adequate to convey flue or vent gasses to the outdoors.
3. If this boiler is being installed in Massachusetts, follow the Massachusetts Code instructions printed later in this section.
4. Consult the vent pipe manufacturer's instructions for vent system assembly and system specific installation requirements.

### **⚠ WARNING**

**Vent pipe system must be made of materials approved for use with condensing flue gasses.**

5. Vent pipe system shall be acceptable for use with boiler fuel type.
6. Vent pipe system shall be compatible either by directly connecting, or by use of an adapter, to the boiler vent connection.
  - a. This boiler is shipped with a Heat-Fab Saf-T-Vent connection.
  - b. Alteration of the boiler vent connection is prohibited.
7. Do not reduce the diameter of the vent pipe. The vent pipe must not be smaller than the vent connector on the boiler.
8. Vent pipe system must be adequately supported at intervals no less than five (5) feet apart. The completed vent system must be rigid and able to withstand impacts without collapse.
9. If any point of the vent pipe system is higher than the boiler flue collar, the vent system must have adequate condensate drain loop(s) to prevent condensate from running back into the boiler.
10. It is permissible to run vent pipe through a vertical or horizontal chase provided minimum clearances to combustible materials are maintained.

11. The minimum clearance to combustible material is six (6) inches, unless otherwise specified by the vent system manufacturer.
12. Horizontal vent pipe must slope no less than one (1) inch in four (4) feet of run.
13. The vent termination location is restricted as follows:
  - a. Minimum twelve (12) inches above grade plus normally expected snow accumulation or seven (7) feet above grade if located adjacent to public walkways. **DO NOT INSTALL** over public walkway where local experience indicates condensation or vapor from the boiler creates a nuisance or hazard.
  - b. Minimum three (3) feet above any forced air inlet located within ten (10) feet of the vent termination.
  - c. Minimum four (4) feet below, four (4) feet horizontally or one (1) foot above any door, window or gravity air inlet.
  - d. Minimum four (4) feet horizontally from electric meters, gas meters, regulators and relief valves. This distance may be reduced if equipment is protected from damage due to condensation or vapor by enclosure, overhangs, etc.
  - e. Minimum twelve (12) inches from corners of building.
14. Use appropriately designed thimbles when passing through combustible walls or roofs.
15. Install fire-stops where vent passes through floors, ceilings or framed walls. The fire-stop must close the opening between the vent pipe and the structure.
16. Enclose vent passing through occupied or unoccupied spaces above the boiler with materials having a fire resistance rating at least equal to the rating of the adjoining floor or ceiling. Maintain minimum clearance to combustible materials.

## Venting Warnings - French

### **⚠ AVERTISSEMENT**

Une ventilation incorrecte peut conduire à des dommages matériels et le relâchement de fumées de combustion qui contiennent du monoxyde de carbone (CO) mortel dans le bâtiment, ce qui peut provoquer de graves blessures corporelles et/ou la mort.

### **⚠ AVERTISSEMENT**

Le système de conduit de ventilation doit être fabriqué avec des matériaux approuvés pour une utilisation avec des fumées de combustion se condensant.

### **⚠ AVERTISSEMENT**

Ne pas utiliser de volets motorisés ou de volets barométriques avec les systèmes de ventilation à pression positive.

### **⚠ AVERTISSEMENT**

Ne pas réduire la taille de la tuyauterie d'admission d'air.

Lire, comprendre et suivre les restrictions relatives aux instructions d'air de combustion contenues dans les instructions de pré-installation de ce manuel.

### **⚠ ATTENTION**

L'utilisation d'air sale, contaminé ou poussiéreux pour la combustion va diminuer la durée de vie du filtre d'air de la chaudière. Utiliser l'air extérieur si la qualité de l'air intérieur pose problème. Utiliser de l'air extérieur si la chaudière est installée dans des usines de fabrication, laveries, nettoyeurs à sec ou autres sites avec des particules lourdes dans l'air.

### **⚠ AVERTISSEMENT**

Ne pas positionner l'admission d'air là où des distillats de pétrole, CFC, détergents, vapeurs volatiles ou autres produits chimiques sont présents. Une corrosion conséquente et une défaillance de la chaudière pourraient en résulter. Thermal Solutions ne garantit pas les défaillances provoquées par de l'air contaminé.

Ne pas positionner la terminaison de l'admission d'air là où la convection naturelle ou les conditions de vent peuvent causer les gaz évacués de la chaudière à être AVERTISSEMENT entraînés dans l'admission d'air.

17. Locate vent terminal above combustion air intake terminal (if used) and no closer than one (1) foot horizontally.
18. Vertical venting requires flashing and a storm collar to prevent moisture from entering the structure.
19. Vertical vent termination must be at least two (2) feet plus the expected snow accumulation above roof penetration height.
20. This boiler's venting may be Category IV (positive vent pressure, flue condensing) or Category II (non-positive vent pressure, flue condensing), with regards to National Fuel Gas Code/NFPA 54 ANSI Z223.1.

**B. Positive Pressure Venting Requirements**

1. Vent pipe system must be fully sealed.

**⚠ WARNING**

**Do not use vent dampers or barometric dampers with positive pressure vent systems.**

2. Direct vent applications: For direct vent (ducted combustion air) installations, the maximum vent length is 50 equivalent feet. The vent length is equal to the total length of straight pipe plus the equivalent length of vent fittings.
  - a. 90° elbow = 5 ft. and 45° elbow = 3 ft.
3. Non-direct vent applications: For non-direct vent installations (those without ducted combustion air), design the vent system so that the pressure measured at the outlet of the boiler is between 0" w.c. and 0.3" w.c. at high fire.
4. For sidewall venting, slope pipe toward vent termination, if possible.
5. See Figures 2, 3 and 4 for examples of positive pressure venting arrangements.

**C. Negative Pressure Venting Requirements**

This section outlines requirements for conventional venting installations, where a negative pressure at

the boiler flue outlet is achieved by means of natural convection through a vertical length of vent pipe or lined chimney.

1. Refer to Figure 5 for an example of a typical conventional venting arrangement.
2. A lined chimney or vertical length of vent pipe may be used. Chimney lining must be acceptable for use with condensing flue gas.
3. The minimum chimney/vertical vent height is 15 feet.
4. Install a condensate drain to collect any condensate that may form in the lined chimney/vertical vent.
5. Install a double acting barometric damper with integral flue spillage interlock.
6. The chimney/vertical vent and flue connector must be sized and configured to provide a minimum - 0.04 inch w.c. pressure (draft) at the boiler flue outlet.
7. The chimney must be protected from down drafts, rain and debris by using a chimney cap or star.

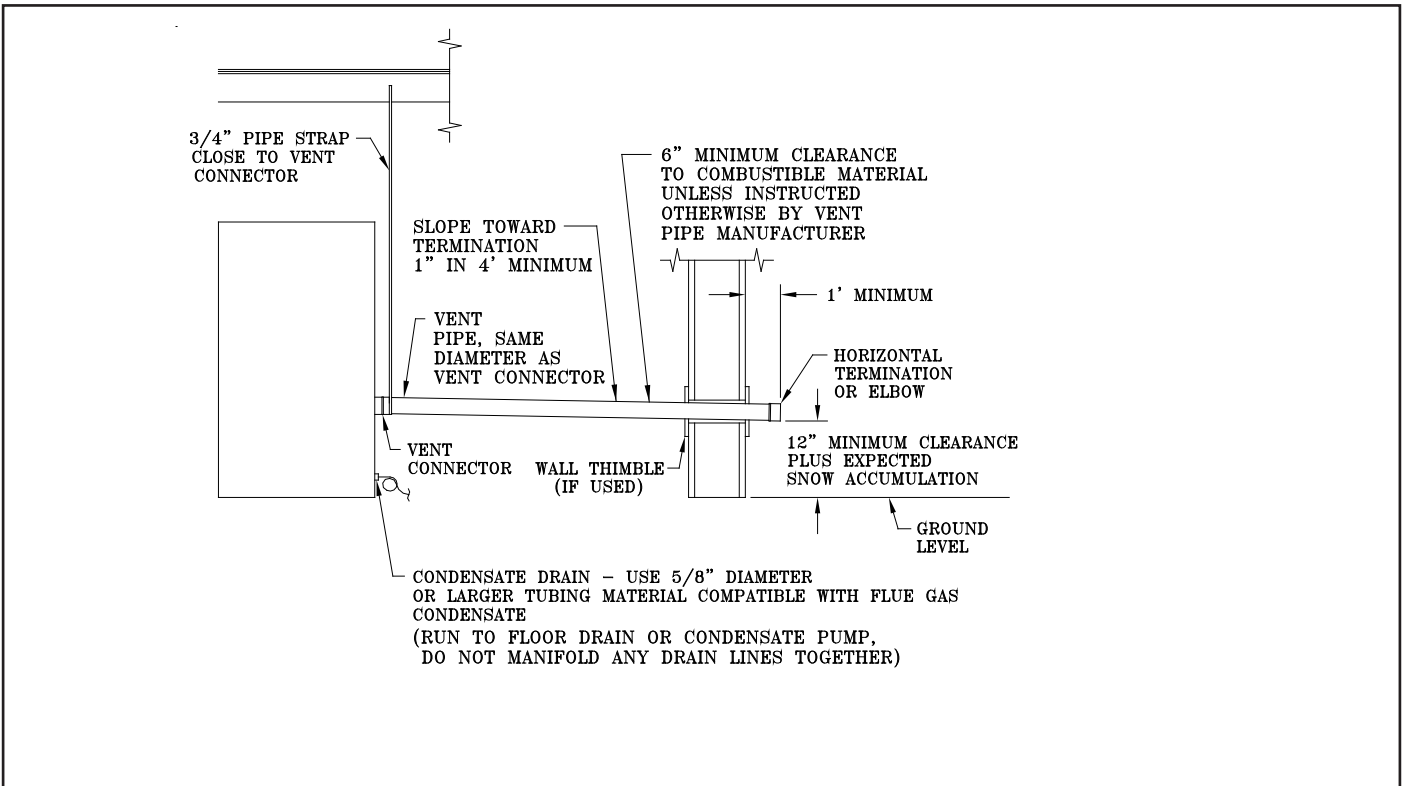
**D. General Guidelines**

1. This boiler has been certified with AL29-4C® venting. Select a vent material that is approved for use with condensing flue gasses.
2. Install vent system before installing air intake, water, gas or electrical connections.
3. For instances where the vent system manufacturer's instructions do not make a specification, refer to the below points.
  - a. Make sure pipe and fittings are clean by swabbing with alcohol. Use Dow Corning 736 or 732 RTV, Polybar #500 RTV or Sil-bond 4500 or 6500 to seal vent pipe.
  - b. Refer to the appropriate drawings in this section of this manual to determine common acceptable configurations of venting system.

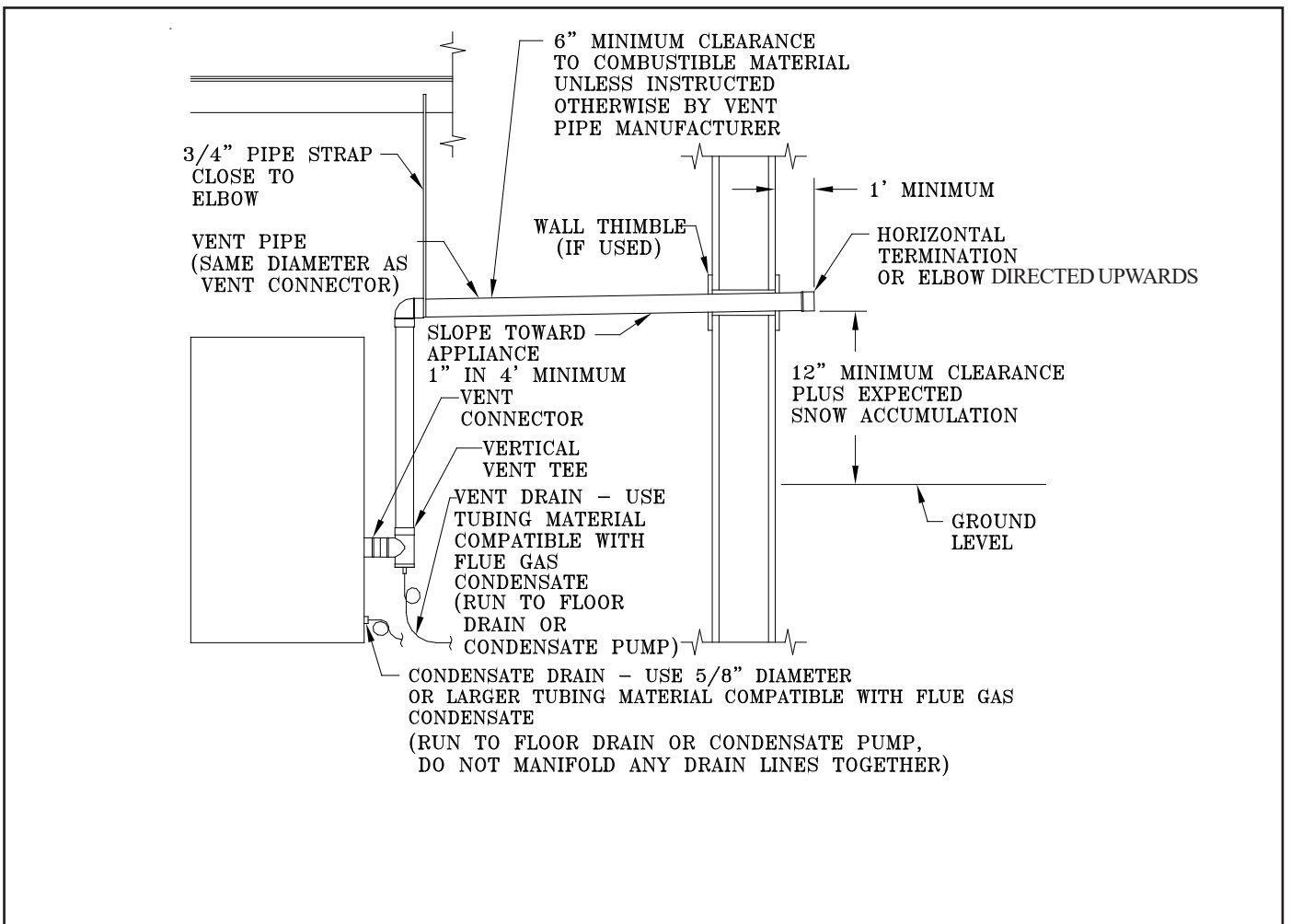
**Combustion Air Required and Flue Gas Flow Rate**

Model	At Maximum Input Rate		At Minimum Input Rate	
	Flue Gas Flow, ACFM @ 30% Excess Air, 325 °F	Combustion Air, SCFM @ 30% Excess Air, 60 °F	Flue Gas Flow, ACFM @ 30% Excess Air, 325 °F	Combustion Air, SCFM @ 30% Excess Air, 60 °F
500	167	102	56	34
750	251	153	84	51
1000	335	205	112	68
1500	502	307	167	102
2000/2000S	669	409	223	136
2500	836	511	279	171
3000	1004	614	335	205

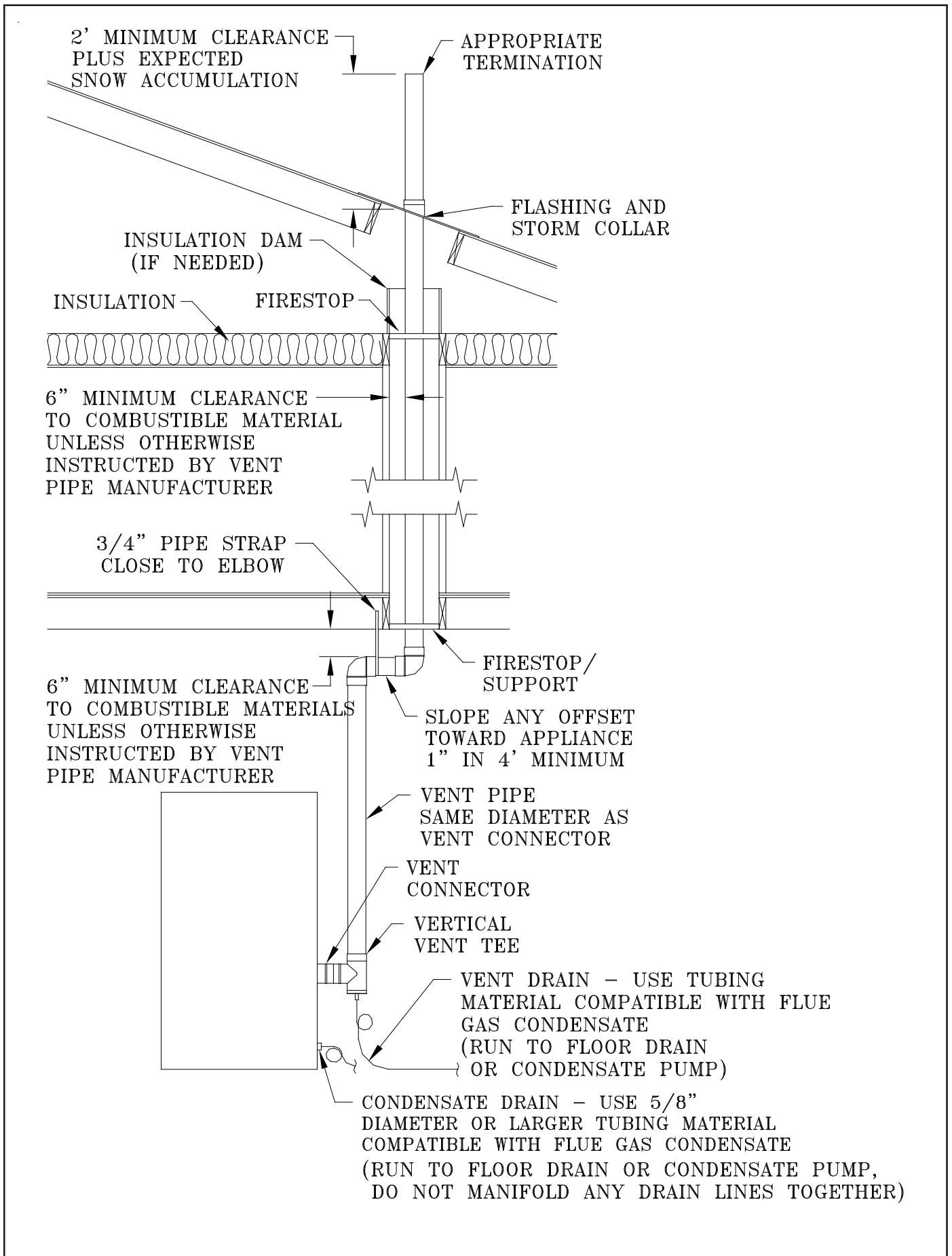
Note: Flow rates are based on the combustion of natural gas.



**Figure 2: Sidewall Positive Pressure Venting**



**Figure 3: Sidewall Positive Pressure Venting (Optional)**



**Figure 4: Vertical Pressurized Venting**

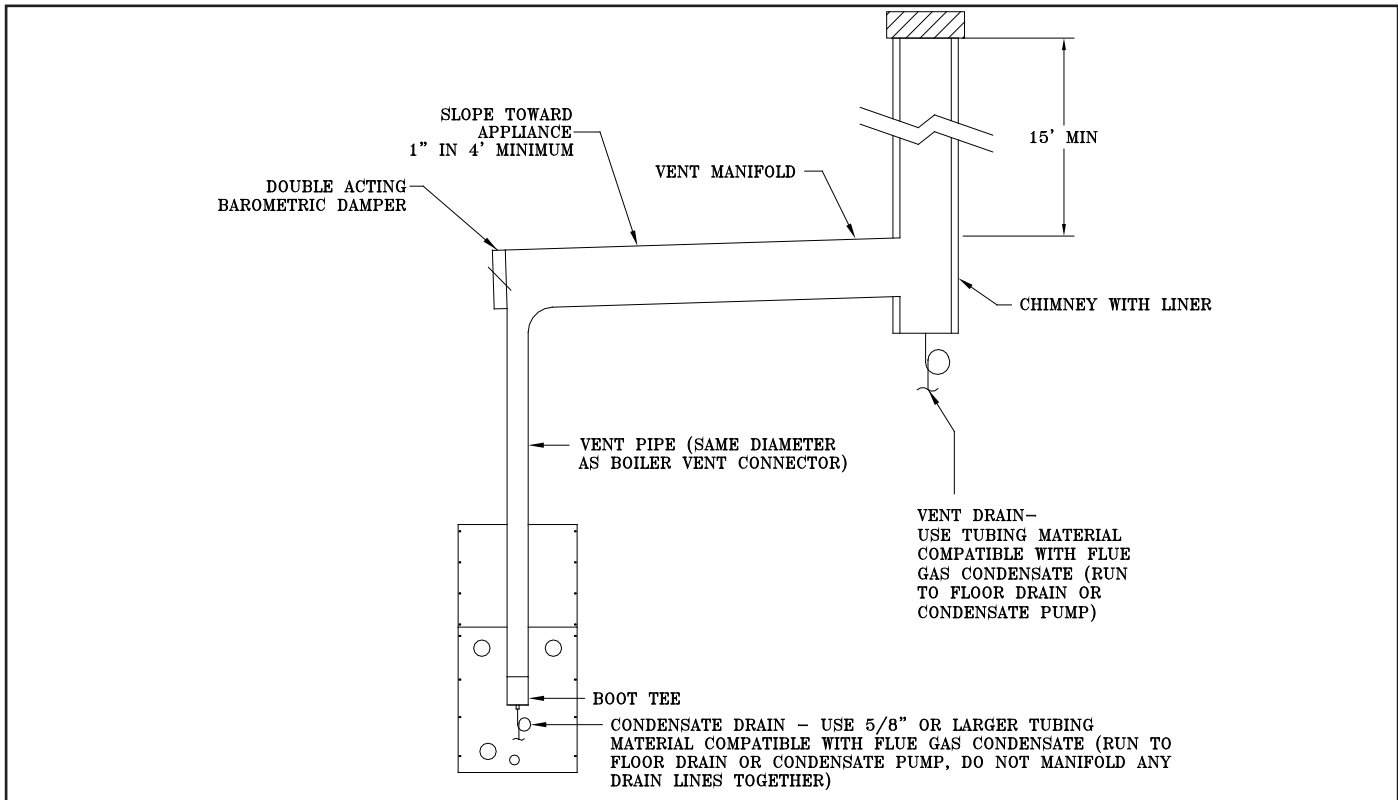


Figure 5: Typical Negative Pressure (Conventional) Venting

### E. IMPORTANT

The Commonwealth of Massachusetts requires compliance with regulation 248 CMR 4.00 and 5.00 for installation of side-wall vented gas appliances as follows:

1. For all side wall horizontally vented gas fueled equipment installed in every dwelling, building or structure used in whole or in part for residential purposes, including those owned or operated by the Commonwealth and where the side wall exhaust vent termination is less than seven (7) feet above finished grade in the area of the venting, including but not limited to decks and porches, the following requirements shall be satisfied:

- a. INSTALLATION OF CARBON MONOXIDE DETECTORS. At the time of installation of the side wall horizontal vented gas fueled equipment, the installing plumber or gasfitter shall observe that a hard wired carbon monoxide detector with an alarm and battery back-up is installed on the floor level where the gas equipment is to be installed. In addition, the installing plumber or gasfitter shall observe that a battery operated or hard wired carbon monoxide detector with an alarm is installed on each additional level of the dwelling, building or structure served by the side wall horizontal vented gas fueled equipment. It shall be the responsibility of the property owner to secure the services of qualified licensed professionals for the installation of hard wired carbon monoxide detectors.
- b. In the event that the side wall horizontally vented gas fueled equipment is installed in a crawl space or an attic, the hard wired carbon monoxide detector with alarm and battery back-up may be installed on the next adjacent floor level.

- c. In the event that the requirements of this subdivision can not be met at the time of completion of installation, the owner shall have a period of thirty (30) days to comply with the above requirements; provided, however, that during said thirty (30) day period, a battery operated carbon monoxide detector with an alarm shall be installed.
2. APPROVED CARBON MONOXIDE DETECTORS. Each carbon monoxide detector as required in accordance with the above provisions shall comply with NFPA 720 and be ANSI/UL 2034 listed and IAS certified.
3. SIGNAGE. A metal or plastic identification plate shall be permanently mounted to the exterior of the building at a minimum height of eight (8) feet above grade directly in line with the exhaust vent terminal for the horizontally vented gas fueled heating appliance or equipment. The sign shall read, in print size no less than one-half (1/2) inch in size, "GAS VENT DIRECTLY BELOW. KEEP CLEAR OF ALL OBSTRUCTIONS".
4. INSPECTION. The state or local gas inspector of the side wall horizontally vented gas fueled equipment shall not approve the installation unless, upon inspection, the inspector observes carbon monoxide detectors and signage installed in accordance with the provisions of 248 CMR 5.08(2)(a) 1 through 4.
  - a. EXEMPTIONS: The following equipment is exempt from 248 CMR 5.08(2)(a)1 through 4:
  - b. The equipment listed in Chapter 10 entitled "Equipment Not Required To Be Vented" in the most current edition of NFPA 54 as adopted by the Board; and
  - c. Product Approved side wall horizontally vented gas fueled equipment installed in a room or structure separate from the dwelling, building or structure used in whole or in part for residential purposes.
5. MANUFACTURER REQUIREMENTS - GAS EQUIPMENT VENTING SYSTEM PROVIDED. When the manufacturer of Product Approved side wall horizontally vented gas equipment provides a venting system design or venting system components with the equipment, the instructions provided by the manufacturer for installation of the equipment and the venting system shall include:
  - a. Detailed instructions for the installation of the venting system design or the venting system components; and
  - b. A complete parts list for the venting system design or venting system.
6. MANUFACTURER REQUIREMENTS - GAS EQUIPMENT VENTING SYSTEM NOT PROVIDED. When the manufacturer of a Product Approved side wall horizontally vented gas fueled equipment does not provide the parts for venting the flue gases, but identifies "special venting systems", the following requirements shall be satisfied by the manufacturer:
  - a. The referenced "special venting system" instructions shall be included with the appliance or equipment installation instructions; and
  - b. The "special venting systems" shall be Product Approved by the Board, and the instructions for that system shall include a parts list and detailed installation instructions.
7. A copy of all installation instructions for all Product Approved side wall horizontally vented gas fueled equipment, all venting instructions, all parts lists for venting instructions, and/or all venting design instructions shall remain with the appliance or equipment at the completion of the installation.

## F. COMBUSTION AIR

1. The boiler may be operated with inside or outside air.
2. Refer to air intake piping drawings in this section for proper outside air installation details.
3. Combustion air conduit can be galvanized smoke pipe, PVC, CPVC, or flexible aluminum conduit.
4. The maximum air intake pipe length is fifty (50) equivalent feet. Air intake pipe length is equal to the total length of straight pipe plus the equivalent length of fittings.
  - a. 90° elbow = 5 ft. and 45° elbow = 3 ft.
5. Consult air intake pipe manufacturer's instructions for proper method of sealing vent pipe sections and fittings. Do not use other adhesives or sealants except as expressly permitted by the vent pipe manufacturer's instructions.

### ⚠ WARNING

**Do not reduce size of air intake pipe.**

**Read, understand and follow combustion air instruction restrictions contained in the Pre-Installation instructions of this manual.**

6. Air intake termination must be located at least twelve (12) inches above grade plus the expected snow accumulation.
7. Boiler may be installed with vertical venting and sidewall intake air or visa versa.

8. The horizontal air intake pipe must be adequately supported with straps or supports no less than five (5) feet apart. The completed air intake pipe system must be rigid and able to withstand impacts without collapse.

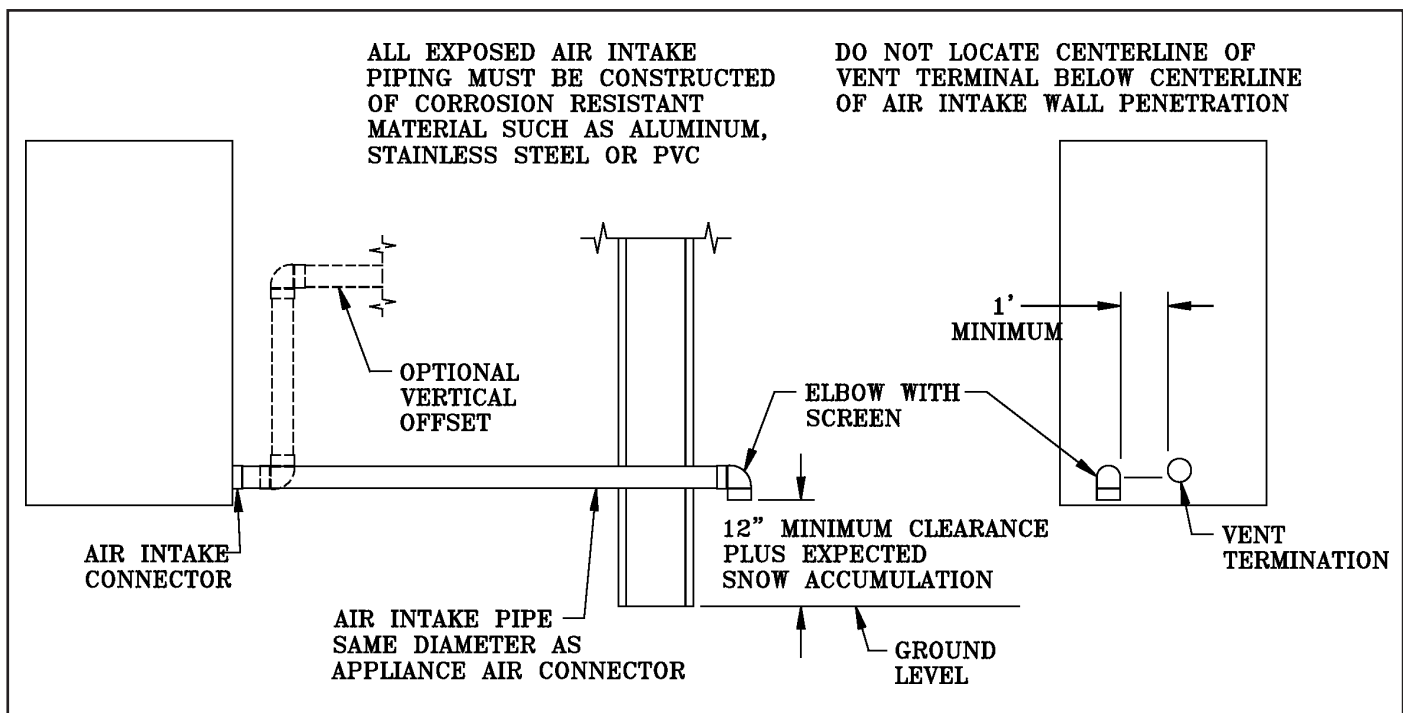
### ⚠ CAUTION

**Dirty, contaminated or dusty air used for combustion will decrease the useful life of the boiler air filter. Use outside air if inside air quality is questionable. Use outside air if the boiler is installed in manufacturing plants, laundries, dry cleaners or other locations with heavy particulates in the air.**

### ⚠ CAUTION

**Do not locate air intake where petroleum distillates, CFCs, detergents, volatile vapors or any other chemicals are present. Severe boiler corrosion and failure will result. Thermal Solutions does not warrant failures caused by contaminated air.**

**Do not locate air intake termination where natural convection or wind conditions may cause the boiler exhaust gases to be drawn into the air intake.**



**Figure 6: Horizontal Air Intake Piping**

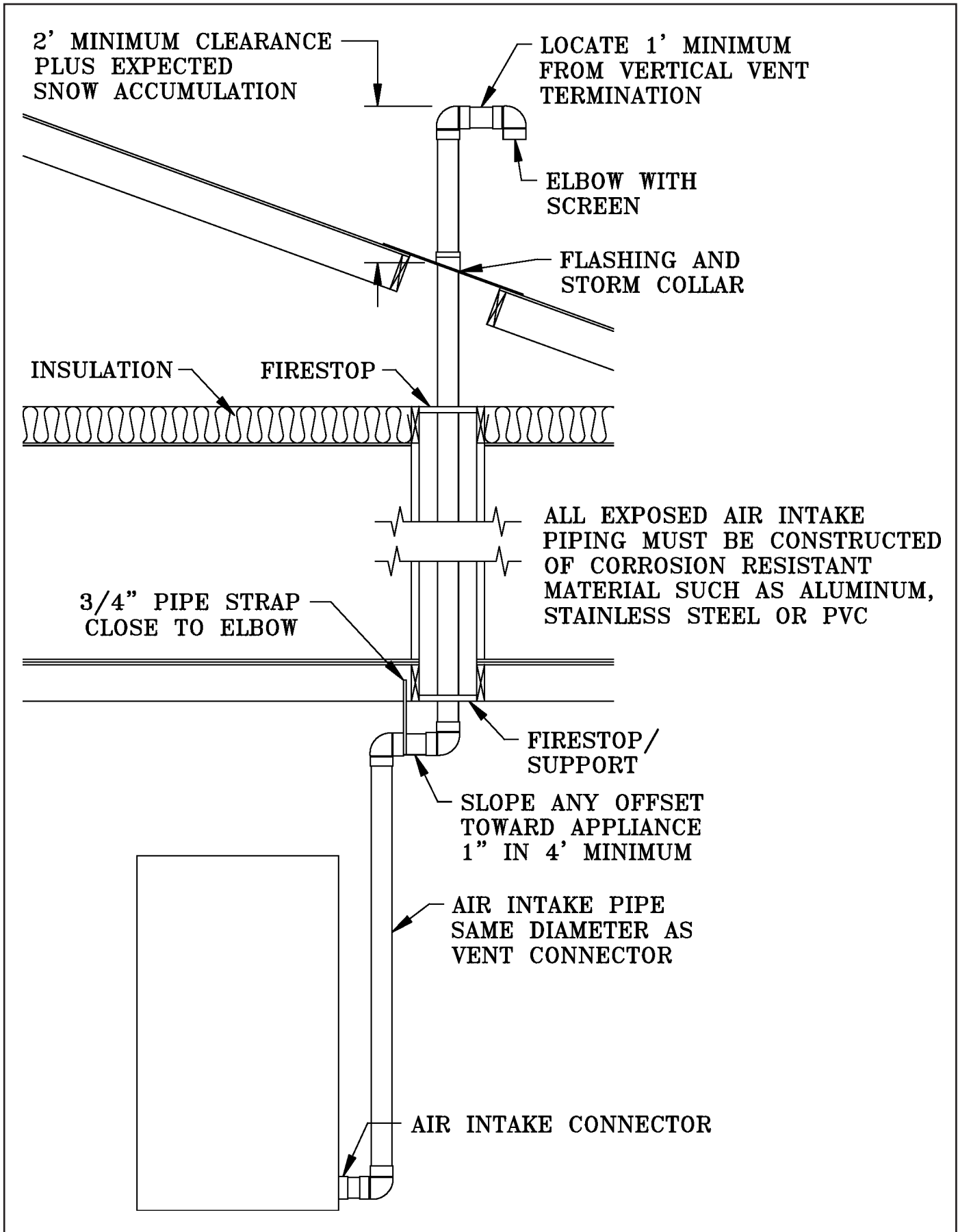


Figure 7: Vertical Air Intake Piping

## IV. Water

### A. WATER TREATMENT

1. The water directly in contact with the appliance must meet the requirements in this section. Failure to adhere to the water treatment requirements in this manual can cause damage not covered by warranty to the appliance, pumps, or other components in the system.
2. It will be necessary to gain knowledge of the impurities dissolved in the water and consult with a qualified industrial water treatment professional to establish a treatment plan. In addition, a periodic testing/sampling plan should be developed.
3. To minimize corrosion and scale effects, adhere to the water quality requirements in Table 1.
  - a. If the water hardness is higher than 340 ppm (20 gpg), a water softener must be used.
  - b. Water with a hardness of less than 50 ppm (3 gpg) before treated with a water softener (naturally soft water) can have a pH level that is corrosive.
4. Total Dissolved Solids (TDS) contribute to scale buildup. The TDS or combined water hardness and TDS shall not exceed 1000 ppm.
5. Chlorine and Chloride can be very corrosive to stainless steel. Ensure the level of chlorine is less than 5 ppm and the level of chloride is less than 150 ppm.
6. Before connecting the appliance, insure the system is free of impurities, grease, sediment, construction dust, and any other contaminants.
  - a. Flush the system thoroughly and repeatedly, if needed.

Table 1: Water Quality Requirements

Quality Parameter	Min.	Max.
Water Hardness (gpg)	-	20
Total Dissolved Solids (ppm)	-	1000
Chlorine (ppm)	-	5
Chloride (ppm)	-	150
pH (cold)	6.5	9.5
pH (systems with aluminum)	7.5	8.5

Note: 1 grain per gallon = 17.1 ppm

#### NOTICE

**This appliance is not designed for the heating of swimming pool water.**

#### NOTICE

**Oxygen contamination of boiler water will cause corrosion of iron and steel boiler components, and can lead to boiler failure. Thermal Solutions Standard Warranty does not cover problems caused by oxygen contamination of boiler water.**

**Proper water treatment and boiler maintenance is required to avoid scale build-up on the inside of the boiler. Thermal Solutions Standard Warranty does not cover problems caused by scale build-up.**

**When using Glycol products, all Glycol manufacturers' requirements, including rust inhibitors, must be adhered. Max 50% Glycol.**

#### NOTICE

**La contamination par l'oxygène de l'eau de la chaudière va provoquer la corrosion des composants en fer et en acier de la chaudière et peut conduire à la défaillance de la chaudière. La garantie standard de Thermal Solutions ne couvre pas les problèmes causés par la contamination par l'oxygène de l'eau de la chaudière.**

**Un traitement de l'eau et une maintenance de la chaudière corrects sont nécessaires afin d'éviter le dépôt de calcaire à l'intérieur de la chaudière. La garantie standard de Thermal Solutions ne couvre pas les problèmes causés par le dépôt de calcaire.**

**Lors de l'utilisation de produits Glycol, toutes les exigences des fabricants de Glycol, incluant les inhibiteurs de rouille, doivent être respectées. Max 50% de Glycol.**

## B. WATER PIPING AND TRIM

### NOTICE

**Failure to properly pipe boiler may result in improper operation and damage to boiler or structure.**

**All piping either new or existing must be cleaned with a tri sodium phosphate (TSP) solution to remove mill scale and oils from the system. Failure to do so could result in premature failure of the heat exchanger (not covered by Thermal Solutions Standard Warranty).**

**On an existing or retrofit system, a filter or strainer must be installed on the system return prior to the boilers.**

**Return water temperature below 130°F will cause flue gas condensation inside the boiler. Flue gas condensate can lead to boiler failure. Thermal Solutions Standard Warranty does not cover problems caused by flue gas condensation.**

**Supply and return water temperature differences greater than 40°F at high fire can lead to boiler failure. Thermal Solutions Standard Warranty does not cover problems caused by temperature differences greater than 40°F at high fire.**

1. Design and install boiler and system piping to prevent oxygen contamination of boiler water and frequent water additions.
  - a. There are many possible causes of oxygen contamination such as:
    - i. Addition of excessive make-up water as a result of system leaks.
    - ii. Absorption through open tanks and fittings.
    - iii. Oxygen permeable materials in the distribution system.
  - b. In order to insure long product life, oxygen sources must be eliminated. This can be accomplished by taking the following measures:
    - i. Repairing system leaks to eliminate the need for addition of make-up water.
    - ii. Eliminating and/or repairing fittings which allow oxygen absorption.
    - iii. Using of non-permeable materials in the distribution system.
    - iv. Isolating the boiler from the system water by installing a heat exchanger.
    - v. Using properly designed and operating air elimination devices in water piping.
2. Connect system supply and return piping to boiler.
  - a. Refer to Figure 8.
  - b. Consult I=B=R Installation and Piping Guides.

- c. Maintain ½" minimum distance between water piping and combustible material.
- d. Consult Thermal Solutions for unusual system requirements.

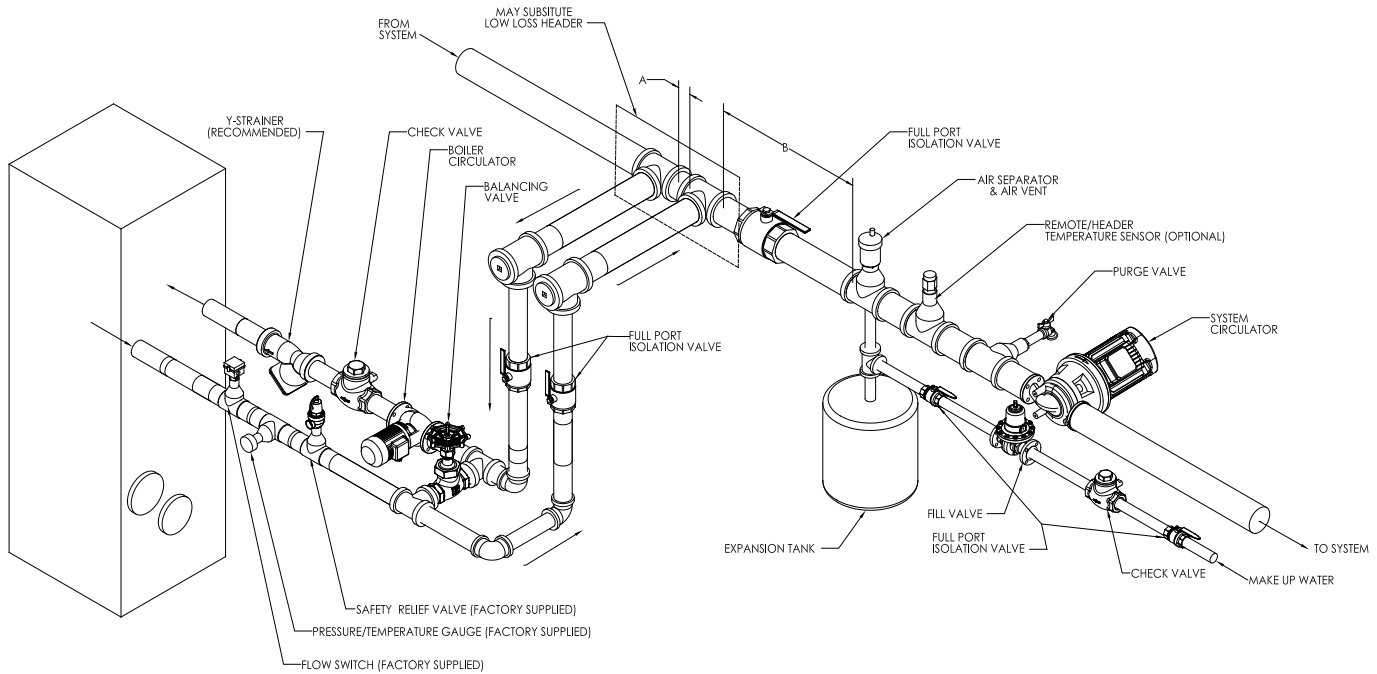
### ⚠ CAUTION

**Support weight of system piping adequately.**

- e. Design and install system piping to prevent return water temperatures below 120°F. Refer to Table 2 for boiler flow and pressure drop requirements.
3. Remove protective cap from boiler drain line located in the rear of the boiler .
4. Install drain valve in the boiler drain line at bottom rear of the boiler.
5. If this boiler is used in connection with refrigeration systems, the boiler must be installed so that the chilled medium is piped in parallel with the boiler using appropriate valves to prevent the chilled medium from entering the boiler. Also consult I=B=R Installation and Piping Guides. If this boiler is connected to heating coils located in air handling units where they may be exposed to refrigerated air, the boiler piping must be equipped with flow control valves to prevent gravity circulation of boiler water during operation of the cooling system.
6. Install optional low water cut-off in system piping above the boiler, if not shipped with boiler.
7. Install an air eliminating device to remove air from the system.

TABLE 2 - EVA BOILER FLOW AND PRESSURE DROP

BOILER MODEL	20°ΔT (at high fire)		40°ΔT (at high fire)		Minimum Flow Rate (gpm)	Maximum Flow Rate (gpm)	Supply/Return Pipe (inch dia.)
	ΔP (Ft.)	Flow (GPM)	ΔP (Ft.)	Flow (GPM)			
EVA-500	2.93	43	0.74	22	22	43	2
EVA-750	1.81	62	0.46	31	31	62	3
EVA-1000	3.24	82	0.81	41	41	82	3
EVA-1500	7.37	125	1.85	63	63	125	3
EVA-2000	13.27	170	3.32	85	85	170	3
EVA-2000S	4.27	173	1.36	87	87	173	4
EVA-2500	4.34	217	1.43	109	109	217	4
EVA-3000	4.41	261	1.73	131	131	261	4



NOTES:  
 1. This is a suggested piping configuration. It is the installer's responsibility to confirm with local codes and ordinances for additional requirements.  
 2. Pressure relief valve setting shall not exceed pressure rating of any component in the system.  
 3. Boiler Pump must be sized to overcome pressure drop across entire boiler loop.

A. NO FURTHER APART THAN 12 INCHES OR FOUR PIPE DIAMETERS, WHICHEVER IS SMALLER  
 B. AT LEAST 18' OF STRAIGHT PIPE FOR CONVENTIONAL AIR SCOOP.

Figure 8: Near Boiler Water Piping (Single Boiler)

Required Common Pipe Size for Multiple Appliances

Model Size	Number of Appliances							
	2	3	4	5	6	7	8	
500	3	4	4	5	5	5	6	
750	3	4	5	5	6	6	8	
1000	4	5	5	6	8	8	8	
1500	5	6	8	8	8	10	10	
2000	6	8	8	10	10	10	12	
2000S	6	8	8	10	10	10	12	
2500	6	8	10	10	10	12	12	
3000	8	8	10	10	12	12	14	

Note: Nominal pipe sizes are listed. Based on 20°F temperature rise.

**⚠ WARNING**

Failure to operate the unit with the proper water flow rate can lead to appliance failure. Always verify proper water flow switch operation so that the unit stops operating if improper water flow is present.

Pressure relief valve discharge piping must be piped such that the potential of severe burns is eliminated. **DO NOT** pipe in any area where freezing could occur. **DO NOT** install any shut-off valves, plugs or caps. Consult Local Codes for proper discharge piping arrangement.

If a high head system pump is installed, ensure that the boiler relief valve and system piping are capable of operating properly at the combined pressure of the system fill pressure plus the pump static head pressure.

Do not install valves, plugs or caps in pressure relief valve piping.

Pressure relief valve piping must be terminated such that in the event the pressure relief valve opens, the discharge will not cause personal injury or damage.

Do not operate the boiler with flow rates in excess of the maximum flow rates listed in Table 2. Tube erosion and pitting will occur. Thermal Solutions Standard Warranty does not cover problems caused by excessive water flow rates.

8. There must be a minimum of five pipe diameters of straight horizontal run downstream of the flow switch. Otherwise, premature failure of flow switch paddle may occur. See flow switch instruction manual included with boiler.
9. If the boiler is installed in a closed water supply system, such as one having a back flow preventer in the cold water supply line, means shall be provided to control thermal expansion. Contact the water supplier or local plumbing inspector on how best to control this situation.
10. A pressure relief valve is supplied with each boiler. No valve is to be placed between the relief valve and appliance.
  - a. Pipe the pressure relief discharge to a suitable place for disposal when relief occurs.
  - b. Do not install reducing couplings or other restrictive devices in the pressure relief discharge line.
  - c. The pressure relief discharge line must allow for complete drainage of both the valve and line.
11. If the relief valve discharges periodically, this may be due to thermal expansion in a closed water supply system. Contact the water supplier or local plumbing inspector on how to correct this situation. **DO NOT PLUG THE RELIEF VALVE.**

**Water Piping Warnings - French**

**⚠ ATTENTION**

Le fait de ne pas connecter correctement a tuyauterie à la chaudière peut conduire à un fonctionnement incorrect et à des dommages à la chaudière ou à la structure.

Toute tuyauterie soit neuve, soit existante doit être nettoyée avec une solution de phosphate tri sodium (TSP) afin d'éliminer les incrustations et les huiles du système. Le fait de ne pas respecter cette procédure pourrait conduire à une défaillance prématurée de l'échangeur de chaleur (non couverte par la garantie standard par Thermal Solutions).

Sur un système existant ou rénové, un filtre ou un tamis doit être installé sur le retour du système avant les chaudières.

Une température d'eau de retour inférieure à 55 °C (130°F) va conduire à une condensation des fumées de combustion à l'intérieur de la chaudière. Le condensat de fumées de combustion peut conduire à une défaillance de la chaudière. La garantie standard de Thermal Solutions ne couvre pas les problèmes causés par la condensation des fumées de combustion.

Des différences de température entre l'eau de retour et l'eau d'alimentation de plus de 22 °C (40 °F) à haut feu peuvent conduire à la défaillance de la chaudière. La garantie standard de Thermal Solutions ne couvre pas les problèmes causés par des différences de température de plus de 22 °C (40°F) à haut feu.

**⚠ ATTENTION**

Assurer un support approprié du poids de la tuyauterie du système. La tuyauterie en boucle de la Chaudière n'est pas conçue pour supporter le poids de la tuyauterie.

## V. Gas Piping

### ⚠ AVERTISSEMENT

Le fait de faire fonctionner l'appareil sans débit correct de l'eau peut conduire à une défaillance de l'appareil. Toujours vérifier le fonctionnement correct de l'interrupteur du débit d'eau afin que l'appareil s'arrête de fonctionner en cas de débit d'eau incorrect.

La tuyauterie de décharge de la soupape de sécurité doit être montée de telle façon que la possibilité de brûlures sévères soit éliminée. **NE PAS** positionner de tuyauterie en toute zone où le gel peut survenir. **NE PAS** installer de vanne d'arrêt, d'obturateurs ou de capuchons. Consulter les Codes Locaux pour un montage correct de la tuyauterie de décharge.

Si une pompe à système de refoulement élevé est installée, s'assurer que la soupape de sécurité et la tuyauterie du système de la chaudière sont capables de fonctionner correctement à la pression combinée de la pression de remplissage du système plus la pression de la pompe à tête statique.

Ne pas installer de clapets, d'obturateurs ou de capuchons dans la tuyauterie de la soupape de sécurité.

La tuyauterie de la soupape de sécurité doit comporter une terminaison de façon à ce qu'en cas d'ouverture de la soupape de sécurité, la décharge ne pourra pas conduire à des blessures corporelles ou des dommages matériels.

Ne pas faire fonctionner la chaudière avec des débits d'eau au-delà des taux de débit maximum listés dans le tableau 2. Une érosion et des piqûres de tube pourraient survenir. La garantie standard de Thermal Solutions ne couvre pas les problèmes causés par des taux excessifs de débit d'eau.

### ⚠ WARNING

Failure to properly pipe gas supply to boiler may result in improper operation and damage to the boiler or structure. Always assure gas piping is absolutely leak free and of the proper size and type for the connected load.

An Additional gas pressure regulator may be needed. Consult gas supplier.

#### A. Gas Piping

1. Size gas piping. Design system to provide adequate gas supply to boiler. Consider these factors.
  - a. Allowable pressure drop from point of delivery to boiler. Refer to Table 3 for minimum and maximum boiler gas train inlet pressure at steady state. If gas supply pressure is higher than maximum as listed in Table 3, an additional field supplied pressure regulator will be required.
  - b. If a lower minimum gas pressure is needed, the low gas pressure build can be used. The minimum gas pressure on all the low gas pressure builds is 4.0 in. w.c. Consult factory if this option is desired. This option is not available on the EVA-500, 2000S, 2500 or 3000.
  - c. Maximum gas demand. Table 7 lists boiler input rate. Also consider existing and expected future gas utilization equipment (i.e., water heater, cooking equipment).
  - d. Length of piping and number of fittings. Refer to Table 4 for maximum capacity of schedule 40 pipe. Table 6 lists equivalent pipe length for standard fittings.
    - i. Specific gravity of gas correction factor, to be applied to the value found in Table 4, can be found in Table 5.
    - ii. For gas piping material other than schedule 40 pipe, refer to the National fuel gas code, NFPA 54/ANSI Z223.1 and/or CAN/GCA B149 Installation codes.
2. If step down regulator is required, it must be used in conjunction with the factory supplied regulator and be located as far away from the boiler as possible to prevent nuisance shutdowns. The minimum and maximum inlet gas pressure must not exceed the value specified in Table 3.
3. Install field supplied sediment trap, ground-joint union and manual non-displacable shut-off valve upstream of factory supplied shut-off valve outside the boiler jacket. Use methods and materials in accordance with Local Codes and requirements of gas supplier. In absence of such requirements, follow National Fuel Gas Code, NFPA 54/ANSI Z223.1 and/or CAN/CSA B149 Installation Codes.

4. Use thread joint compound resistant to the action of liquefied petroleum gas.

**⚠ WARNING**

**Failure to use proper thread compounds on all gas connectors may result in leaks of flammable gas.**

5. All above ground gas piping upstream from field supplied manual gas valve must be electrically continuous and bonded to a grounding electrode. Do not use gas piping as grounding electrode. Refer to National Electrical Code, ANSI/NFPA 70 and /or CSA C22.1 Electrical Codes.

**⚠ WARNING**

**Gas supply to boiler and system must be absolutely shut off prior to installing or servicing boiler gas piping.**

**NOTICE**

**Use an additional gas pressure regulator where the gas pressure is greater than 14"WC. Using one additional regulator for multiple boilers may result in unsafe boiler operation. The additional regulator must be able to properly regulate gas pressure flow at the lowest input of a single boiler. If the regulator cannot do this, two or more additional regulators are required. Consult regulator manufacturer's instructions for minimum gas flow rate.**

6. Pressure test. The boiler and its gas connection must be leak tested before placing boiler in operation.
  - a. Protect boiler gas control valve. For all testing over ½ psig, boiler and its individual shutoff valve must be disconnected from gas supply piping. For testing at ½ psig or less, isolate boiler from gas supply piping by closing boiler's individual manual shutoff valve.
  - b. Locate leaks using approved combustible gas detector, soap and water, or similar nonflammable solution.

**⚠ DANGER**

**Do not use matches, candles, open flames or other ignition source to check for leaks.**

**⚠ AVERTISSEMENT**

**Un défaut d'acheminement correct de l'alimentation en gaz vers la chaudière peut résulter en un fonctionnement incorrect et des dommages à la chaudière ou à la structure. S'assurer toujours que la tuyauterie du gaz est absolument dépourvue de fuites et de la taille et du type corrects pour la charge connectée. Un régulateur supplémentaire de pression de gaz peut être nécessaire. Consulter le fournisseur de gaz.**

**⚠ AVERTISSEMENT**

**L'alimentation en gaz vers la chaudière et le système doit être absolument fermée avant d'installer ou d'entretenir la tuyauterie de gaz de la chaudière.**

**AVIS**

**Utiliser un régulateur de pression de gaz additionnel lorsque la pression de gaz est supérieure à 0,35 bar (5 psig). Utiliser un (1) régulateur additionnel pour de multiples chaudières peut résulter en un fonctionnement dangereux de chaudière. Le régulateur additionnel doit être capable de réguler correctement le débit de gaz à l'entrée la plus basse d'une seule chaudière. Si des régulateurs sont nécessaires. Consulter les instructions du fabricant de régulateurs pour le taux minimum de débit de gaz.**

**Table 3: Inlet Gas Pressures and Pressure Switch Settings**

Model Size	Measured Inlet Pressure			Factory Pressure Switch Setting	
	NG MIN. ("w.c.)	LP MIN ("w.c.)	MAX. ("w.c.)	Low	High
500	5.0	8.0	14.0	3.5	7.0
750	7.0*				
1000	7.0*				
1500	7.0*				
2000	9.0*	9.0			
2000s	7.0	8.0			
2500	6.0				
3000	6.0				

\*Optional natural gas train with 4" w.c. minimum inlet gas pressure.

**TABLE 4: MAXIMUM GAS CAPACITY OF SCHEDULE 40 PIPE.**  
**(Based on Gas Pressure less than 2 psi, pressure drop of 0.3 in w.c. and 0.6 specific gravity.)**

Pipe Length in Equivalent Feet	Pipe Size (in.)							
	3/4	1	1-1/4	1-1/2	2	2-1/2	3	4
	Capacity in Cubic Feet of Gas Per Hour							
10	273	514	1060	1580	3050	4860	8580	17500
20	188	353	726	1090	2090	3340	5900	12000
30	151	284	583	873	1680	2680	4740	9660
40	129	243	499	747	1440	2290	4050	8270
50	114	215	442	662	1280	2030	3590	7330
60	104	195	400	600	1160	1840	3260	6640
70	95	179	368	552	1060	1690	3000	6110
80	89	167	343	514	989	1580	2790	5680
90	83	157	322	482	928	1480	2610	5330
100	79	148	304	455	877	1400	2470	5040
125	70	131	269	403	777	1240	2190	4460
150	63	119	244	366	704	1120	1980	4050
175	58	109	224	336	648	1030	1820	3720
200	54	102	209	313	602	960	1700	3460

**TABLE 5 – SPECIFIC GRAVITY CORRECTION FACTORS**

Specific Gravity	Correction Factor	Specific Gravity	Correction Factor
0.50	1.10	1.10	0.74
0.55	1.04	1.20	0.71
0.60	1.00	1.30	0.68
0.65	0.96	1.40	0.66
0.70	0.93	1.50	0.63
0.75	0.90	1.60	0.61
0.80	0.87	1.70	0.59
0.85	0.84	1.80	0.58
0.90	0.82	1.90	0.56
1.00	0.78	2.00	0.55

**TABLE 6 - EQUIVALENT OF STANDARD PIPE FITTING & VALVES**

Pipe Size	I.D. Inches	Valves Fully Open (Screwed, Flanged, Welded)			Schedule 40, Screwed Fittings			
		Gate	Globe	Angle	Swing Check	90° Elbow (threaded)	45° Elbow (threaded)	90° Tee, Flow through Branch (threaded)
1/2"	0.622	0.36	17.3	8.65	4.32	1.55	0.73	3.10
3/4"	0.824	0.48	22.9	11.4	5.72	2.06	0.96	4.12
1"	1.049	0.61	29.1	14.6	7.27	2.62	1.22	5.24
1-1/4"	1.380	0.81	38.3	19.1	9.58	3.45	1.61	6.90
1-1/2"	1.610	0.94	44.7	22.4	11.2	4.02	1.88	8.04
2"	2.067	1.21	57.4	28.7	14.4	5.17	2.41	10.3
2-1/2"	2.469	1.44	68.5	34.3	17.1	6.16	2.88	12.3
3"	3.068	1.79	85.2	42.6	21.3	7.67	3.58	15.3
4"	4.026	2.35	112	56	28.0	10.1	4.70	20.2
6"	6.065	3.54	168	84.1	42.1	15.2	7.07	30.4

Equivalent lengths are for standard screwed fittings and for screwed, flanged, or welded valves relative to schedule 40 steel pipe.

**NOTICE**

Table 7 lists gas inputs at sea level to 2000 feet altitude. Reduce gas input four percent (4%) for each additional 1000 feet above sea level.

**TABLE 7 - RATED INPUT**

Boiler Model	Rated Capacity (CFH)		Gas Connection Size (inch dia.)
	Natural	LP/Propane	
EVA-500	500	200	1
EVA-750	750	300	1
EVA-1000	1000	400	1-1/2
EVA-1500	1500	600	1-1/2
EVA-2000	2000	800	1-1/2
EVA-2000S	2000	800	1/1/2
EVA-2500	2500	1000	2
EVA-3000	3000	1200	2

## VI. Electrical

### A. ELECTRICAL

1. General. Install wiring and ground boiler in accordance with authority having jurisdiction or in absence of such requirements National Electrical Code, ANSI/NFPA 70 and/or CSA C22.1 Electrical Code.

#### **⚠ WARNING**

**Failure to properly wire electrical connections to the boiler may result in serious physical harm. DO NOT ATTACH ADDITIONAL J-Box to back or top of boiler jacket.**

#### **⚠ DANGER**

**Positively assure all electrical connections are unpowered before attempting installation or service of electrical components or connections of the boiler or building. Lock out all electrical boxes with padlock once power is turned off.**

2. A separate electrical circuit must be run from the main electrical service with an over-current device/disconnect in the circuit. A service switch is recommended and may be required by some local jurisdictions. Locate the service switch such that the appliance can be shut off without exposing personnel to danger in the event of an emergency.
3. Connect the main power supply and ground from fused disconnect to proper boiler electrical leads located in the junction box at the rear of the boiler. Refer to electrical consumption plate on boiler jacket.
4. Remove factory supplied jumper wire from terminals 4 and 5. Connect field supplied safety limits or devices using proper terminals provided in boiler electrical cabinet. Refer to wiring diagram supplied with boiler for wiring information. Refer to Figures 9a-9c for typical wiring diagrams. Refer to Figure 1 for electrical requirements for boiler.

#### **⚠ CAUTION**

**Each boiler must be protected with a dedicated properly sized fused disconnect.**

#### **⚠ WARNING**

**Electrical power may be supplied from more than one service. Make sure all power is off before attempting any electrical work.**

**The wiring diagrams contained in this manual are for reference purposes only. Each boiler may be wired differently according to the specifications given to Thermal Solutions at the time the boiler was purchased. Always use the wiring diagram provided with the boiler. If the wiring diagram provided with the boiler is unavailable, STOP all wiring work and contact Thermal Solutions for a replacement diagram.**

**Do not directly connect low voltage (24 volt, milliamp, etc.) controls to this boiler. If low voltage controls are desired, isolating relays must be used.**

**Never jump out or bypass any safety controls.**

**Never jump out or make inoperative any safety or operating controls. Each boiler must be protected with a properly sized over-circuit device.**

5. The following pages have sample wiring diagrams. Contact Thermal Solutions Representative or visit website ([www.thermalsolutions.com](http://www.thermalsolutions.com)) for current wiring options.
6. An as-built wiring diagram is included with every boiler when it is shipped from the factory.

## Electrical Warnings - French

### **⚠ AVERTISSEMENT**

Le fait de ne pas câbler correctement les connexions électriques à la chaudière peut résulter en un préjudice physique sérieux. **NE PAS INSTALLER DE BOÎTIERS ÉLECTRIQUES ADDITIONNELS** à l'arrière ou au sommet de la chemise de la chaudière.

### **⚠ DANGER**

S'assurer absolument que toutes les connexions électriques ne sont pas sous tension avant d'essayer toute installation ou entretien de composants ou connexions électriques de la chaudière ou du bâtiment. Verrouiller tous les boîtiers électriques avec un cadenas une fois le courant coupé.

### **⚠ ATTENTION**

Chaque chaudière doit être protégée avec une déconnexion par fusible dédié correctement dimensionné.

### **⚠ WARNING**

La puissance électrique peut être fournie par plus d'un service. S'assurer que toute la puissance est coupée avant d'essayer tout travail électrique.

Les diagrammes de câblage contenus dans ce manuel sont fournis seulement à titre de référence. Chaque chaudière peut être câblée de façon différente selon les spécifications

données à Thermal Solutions au moment de l'achat de la chaudière. Utiliser toujours le diagramme de câblage fourni avec la chaudière. Si le diagramme de câblage fourni avec la chaudière n'est pas disponible, **ARRÊTER** tout travail de câblage et contacter Thermal Solutions pour obtenir un diagramme de remplacement.

Ne pas connecter directement de commande basse tension (24 volt, milliampère, etc.) à cette chaudière. Si des commandes basse tension sont nécessaires, des relais isolants doivent être utilisés.

Ne jamais court-circuiter ou contourner toute commande de sécurité.

Ne jamais court-circuiter ou rendre inopérant toute commande de sécurité ou de fonctionnement. Chaque chaudière doit être protégée avec un dispositif de surs tension correctement dimensionné.

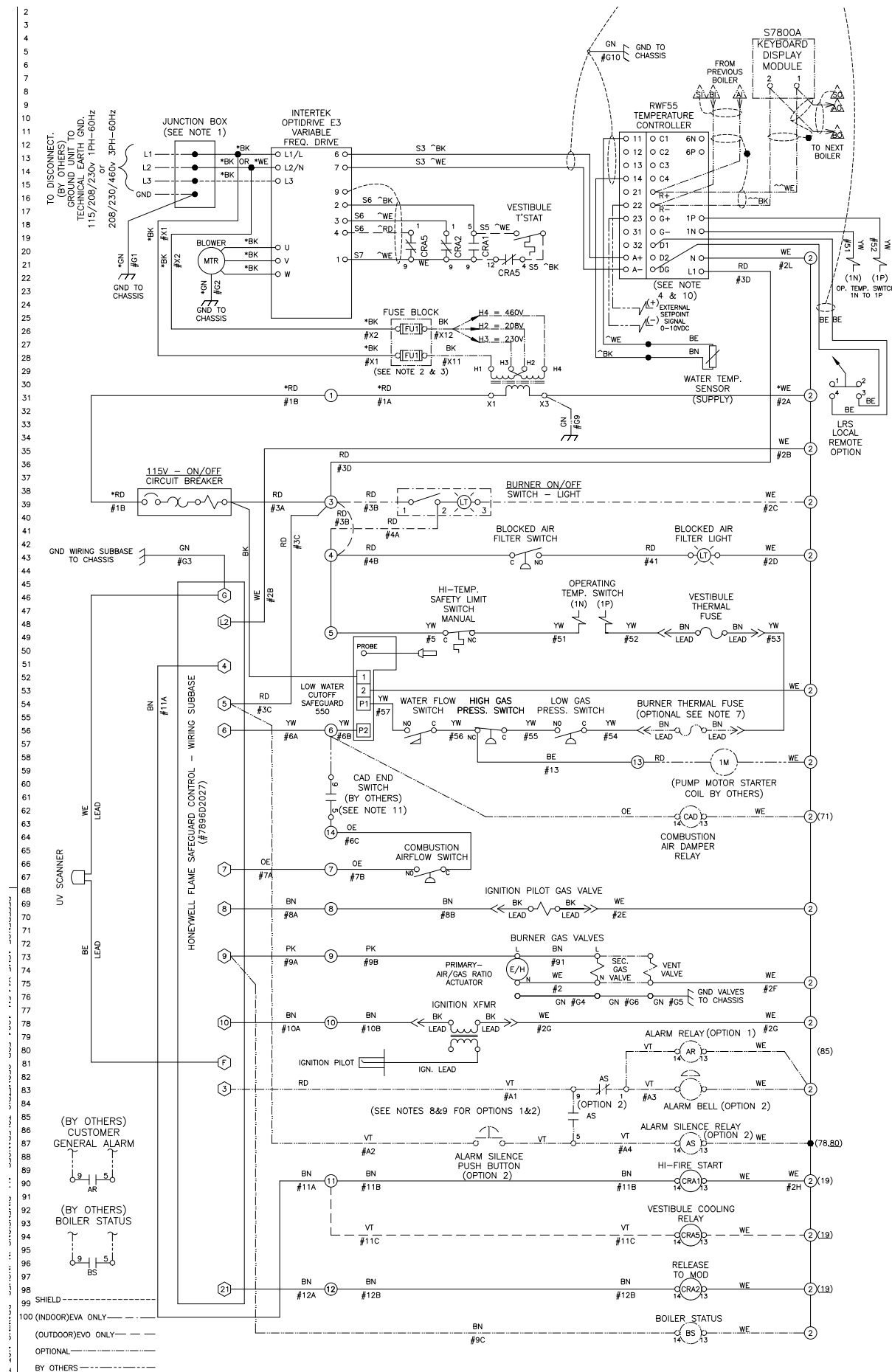


Figure 9b: Standard UL/FM/CSD-1 Wiring Diagram (Modulation) EVA 500-2000



## VII. Modular Systems

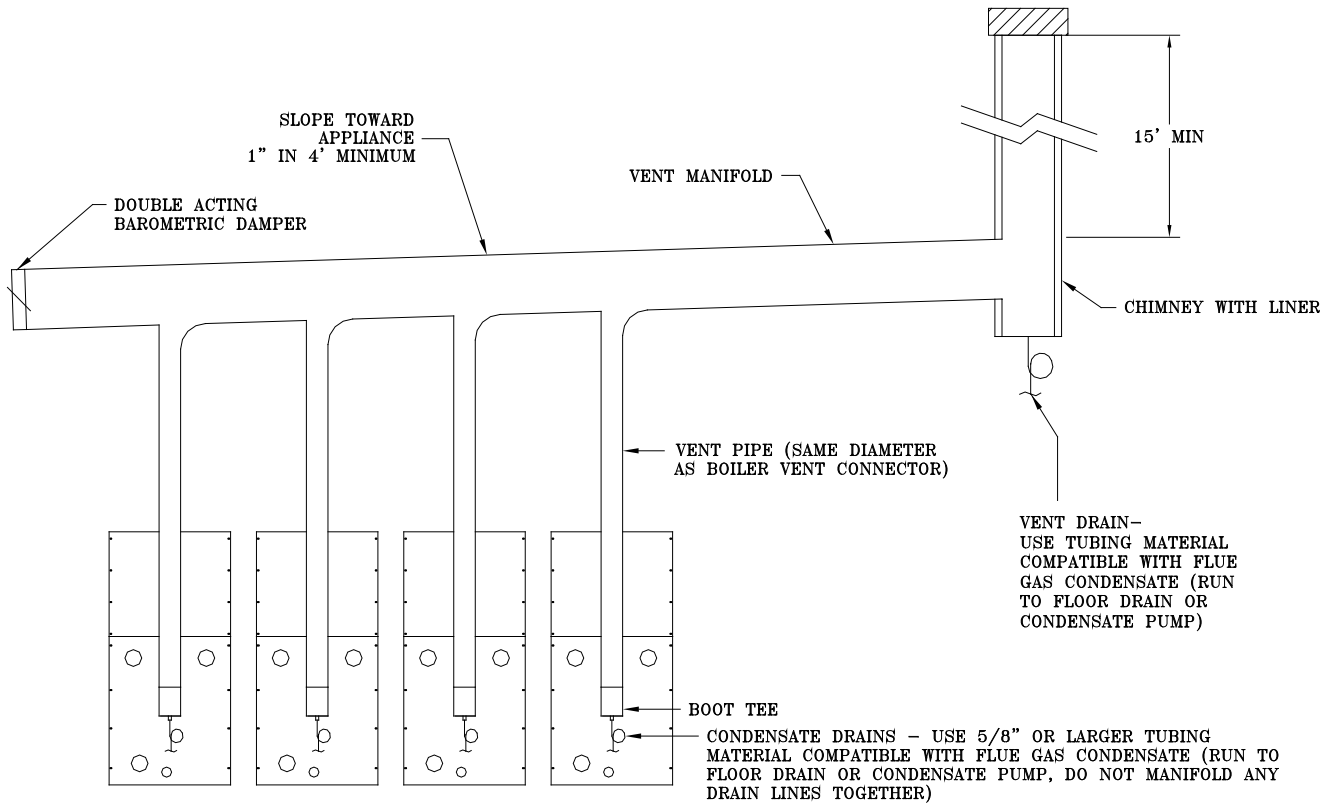


Figure 10: Modular System: Conventional Venting (Negative Pressure)

### A. MODULAR SYSTEMS

#### 1. General Guidelines

- Read and follow all venting, combustion air, water piping, gas piping and electrical instructions contained in this manual unless otherwise instructed in this section.
- Design and installation of modular systems should only be undertaken by skilled and knowledgeable engineers and contractors.
- Consult Local Building Codes, National Fuel Gas Code, or NFPA 54/ANSI Z223.1 for restrictions and instructions for modular boilers.
- Refer to the Pre-Installation section for further warnings, cautions, notices and instructions.

#### 2. Module Sizing

- Consult factory for recommended number and size of boilers for a given input.

#### 3. Venting

This section outlines venting requirements for multiple boiler installations and should be used in addition to the "VENTING" section earlier in this manual.

- Positive Pressure (Sidewall and Vertical) Venting
  - Positive pressure vent systems cannot be manifolded together.

- Positive pressure systems can be piped individually through a common vertical or horizontal chase provided minimum clearances to combustible materials are maintained.
- Positive pressure systems can be piped individually through a common vertical chase so that a single roof penetration can be made. Each vent termination must be one (1) foot from all other terminations.

#### ⚠ WARNING

**DO NOT manifold vent components of multiple boilers without converting to a negative pressure venting arrangement.**

#### b. Negative Pressure (Conventional) Venting

- Refer to Figure 10 for an example of a typical conventional venting arrangement for modular boilers.
- Refer to National Fuel Gas Code to determine required chimney diameter and common venting diameter. Note that combined input, lateral length and chimney height affect vent diameter.
- Install a double acting barometric damper with integral flue spillage interlock (as shown in Figure 10).

- iv. Locate boiler(s) with lowest input closest to chimney/vertical common vent.
- v. Chimney lining must be acceptable for use with condensing flue gases.
- vi. Install a condensate drain to collect any condensate that may form in the lined chimney or vertical common vent (refer to figure 10).

**⚠ CAUTION**

**Installing multiple vent terminations close together promotes frost build up on buildings. To minimize this possibility, extend the distance from the building to the end of the vent termination and increase the horizontal distance between vent terminations.**

- 4. Air Intake Piping
  - a. Consult intake pipe manufacturer for common air intake pipe sizing.
  - b. Refer to Figures 11 and 12 for common air intake guidelines for modular boilers.
  - c. Individual air intake pipes may be used in lieu of common air intake piping.
  - d. Common air intake straight lengths and fittings should be assumed to have the equivalent length the same as an individual air intake pipe, used for a given boiler intake pipe diameter.
  - e. Position horizontal air intake termination center line below horizontal vent termination's center line.
  - f. Vertical air intake pipe must terminate at least two (2) feet above the closest portion of the roof.
  - g. Refer to the Combustion Air section for further warnings, cautions, notices and instructions.
- 5. Water Piping
  - a. Refer to Figures 13 thru 15 for typical water piping for modular boilers.
  - b. Installing a low water cut-off in the system piping is highly recommended and may be required by Code, if not factory mounted on boiler.
  - c. Refer to Table 1 for pressure drop and flow requirements for each boiler.
  - d. Consult I=B=R Installation and Piping Guide.
  - e. Maintain ½" minimum distance between water piping and combustible material.
  - f. Refer to Water Piping and Trim section for further warnings, cautions, notices and instructions.
- 6. Gas Piping

- a. Refer to National Fuel Gas Code, Local Codes and Tables 2 through 7 for gas pipe sizing.
- b. Refer to Gas Piping section for further warnings, cautions, notices and instructions.

**NOTICE**

**The pressure drop of each system fitting and component must be added to the boiler pressure drop to determine the system pressure head requirement. See Table 6 for fitting and component equivalent lengths.**

**⚠ AVERTISSEMENT**

**NE PAS relier des composants de ventilation de plusieurs chaudières sans une conversion à un montage de ventilation à pression négative.**

**⚠ ATTENTION**

**L'installation de plusieurs terminaisons de ventilation rapprochées favorise l'accumulation de gel sur les bâtiments. Afin de minimiser cette possibilité, accroître la distance entre le bâtiment et l'extrémité de la terminaison de ventilation et augmenter la distance horizontale entre les terminaisons de ventilation.**

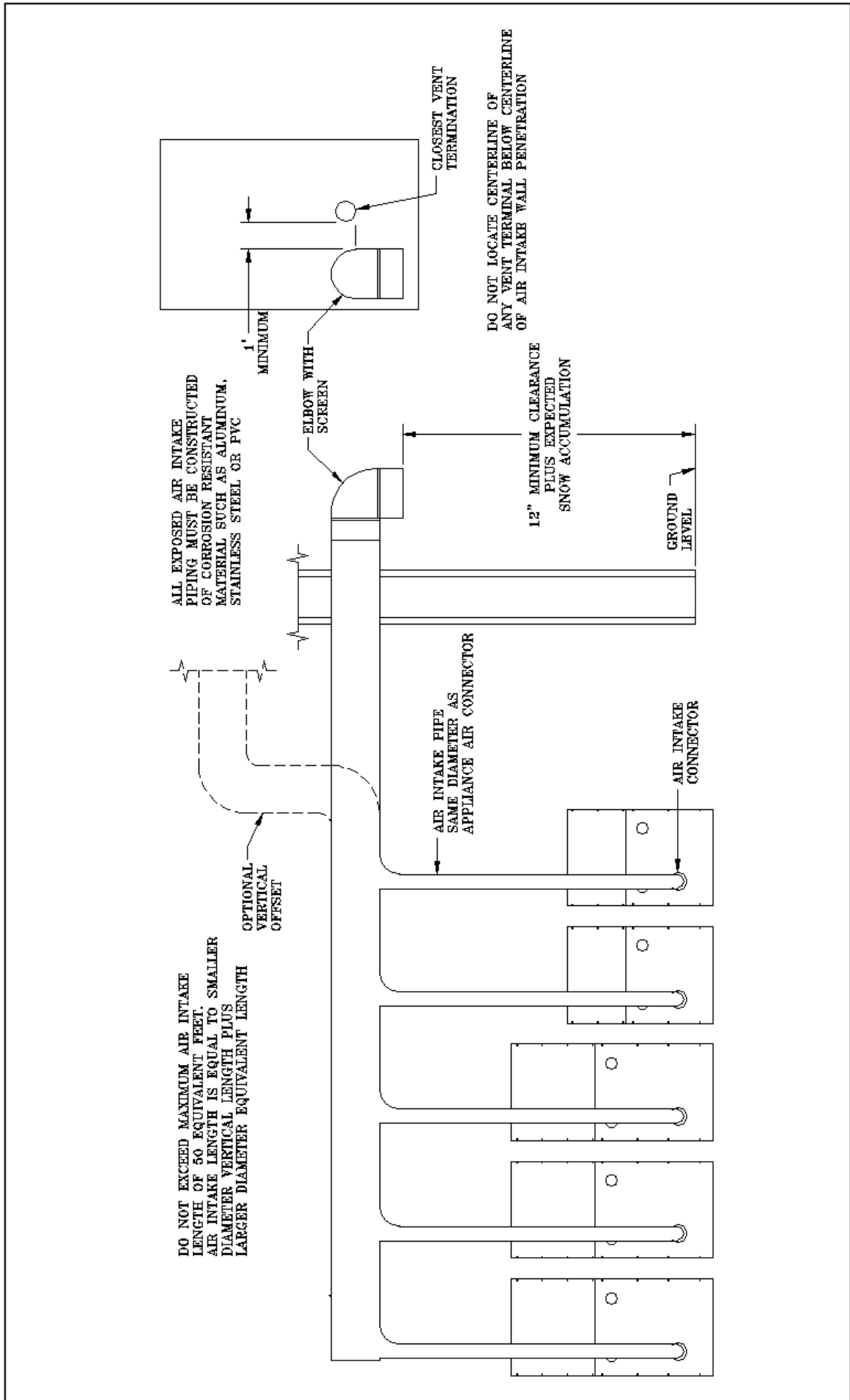


Figure 11: Modular System Horizontal Air Intake Piping

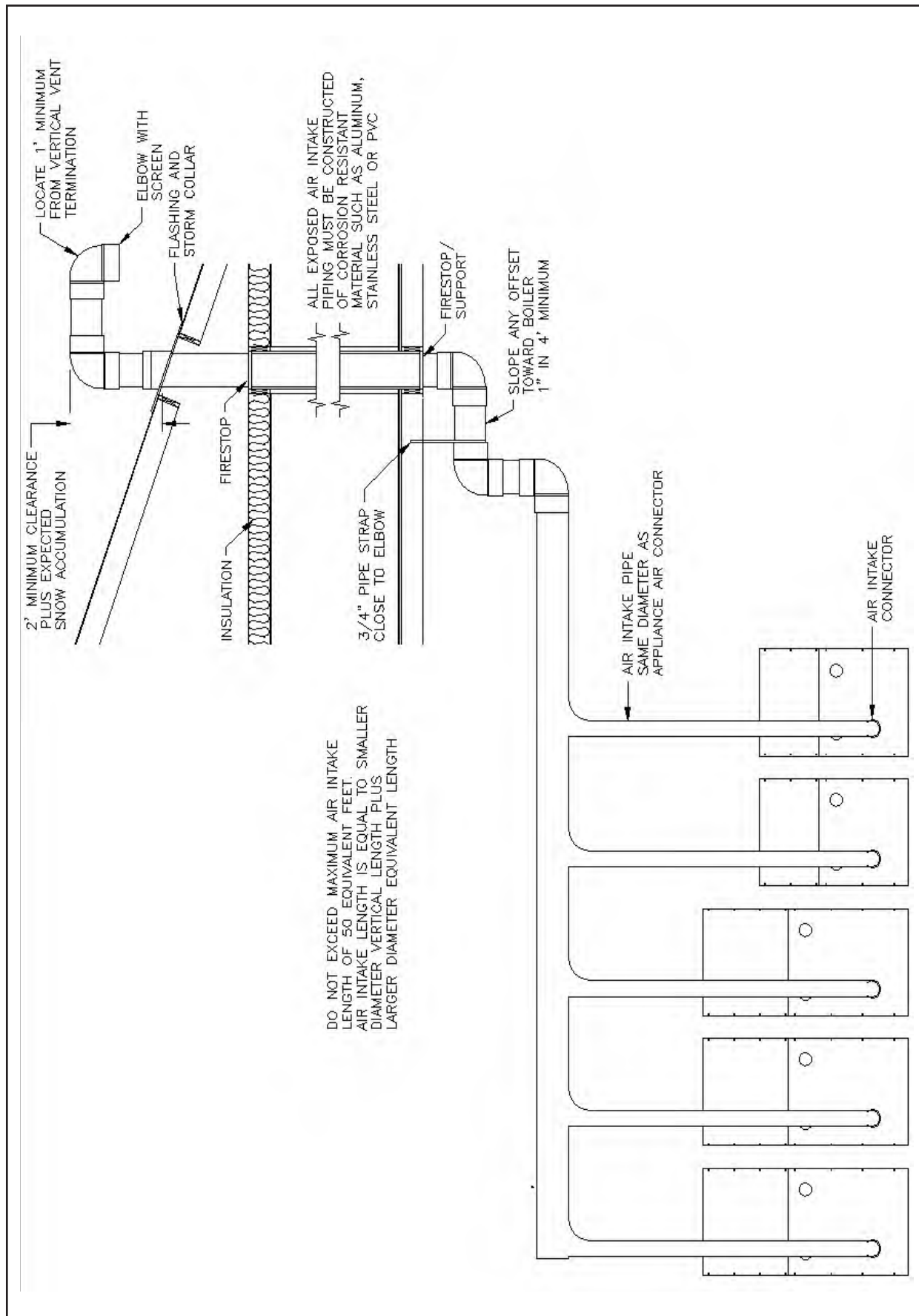


Figure 12: Modular System Vertical Air Intake Piping

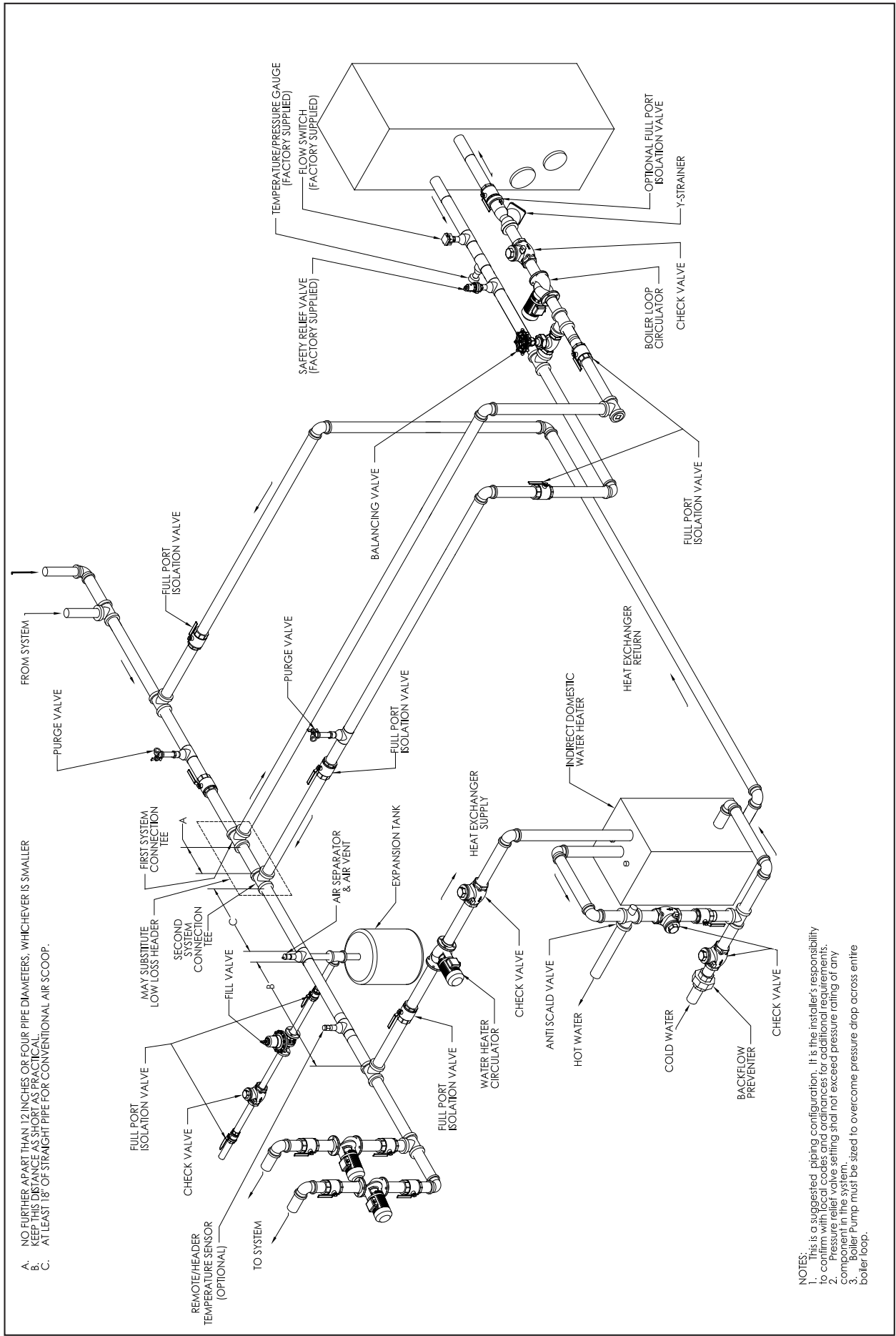
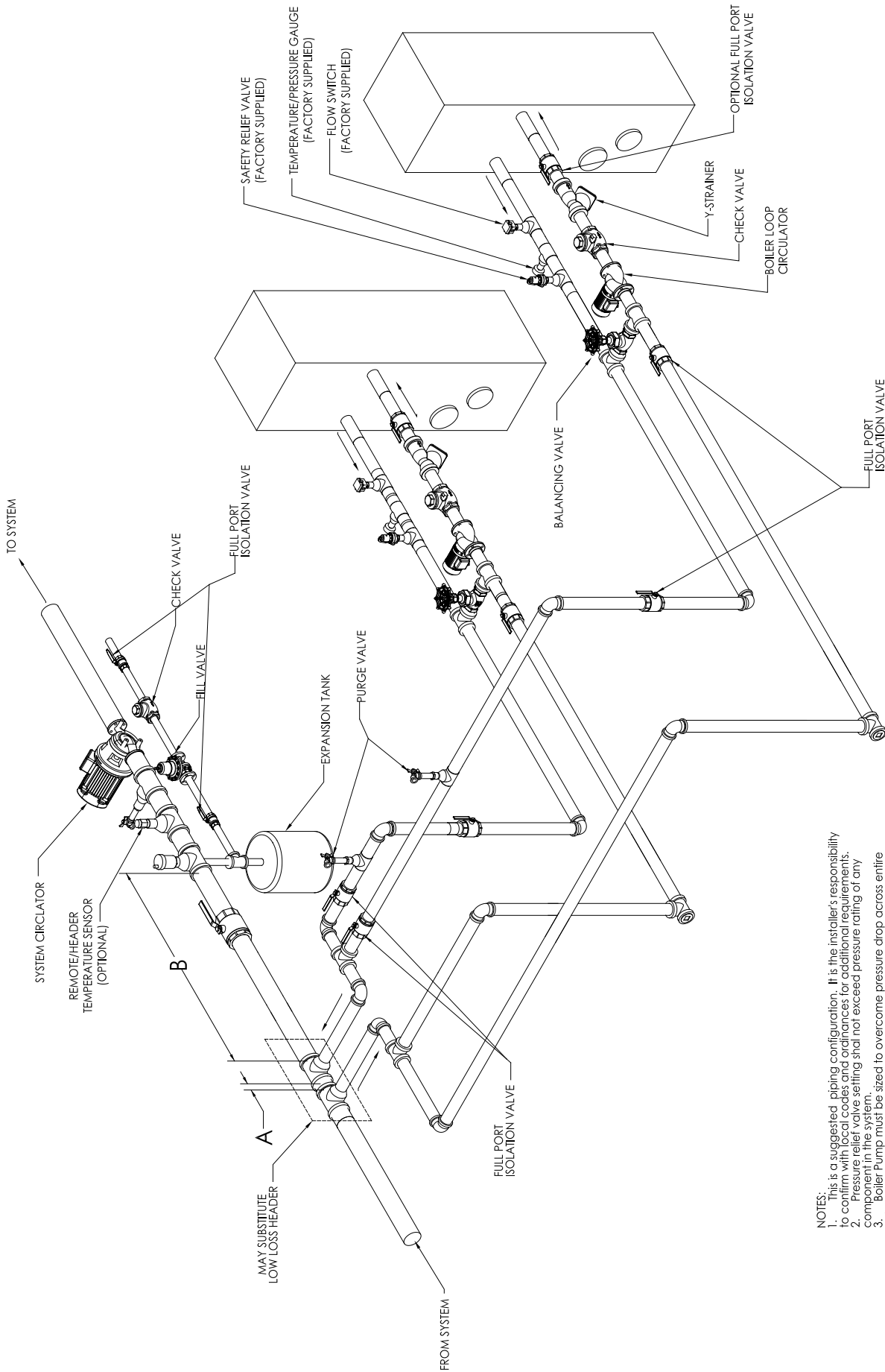


Figure 13: Near Boiler Water Piping with Domestic Hot Water

- A. NO FURTHER APART THAN 12 INCHES OR FOUR PIPE DIAMETERS, WHICHEVER IS SMALLER
- B. AT LEAST 18" OF STRAIGHT PIPE FOR CONVENTIONAL AIR SCOOP.



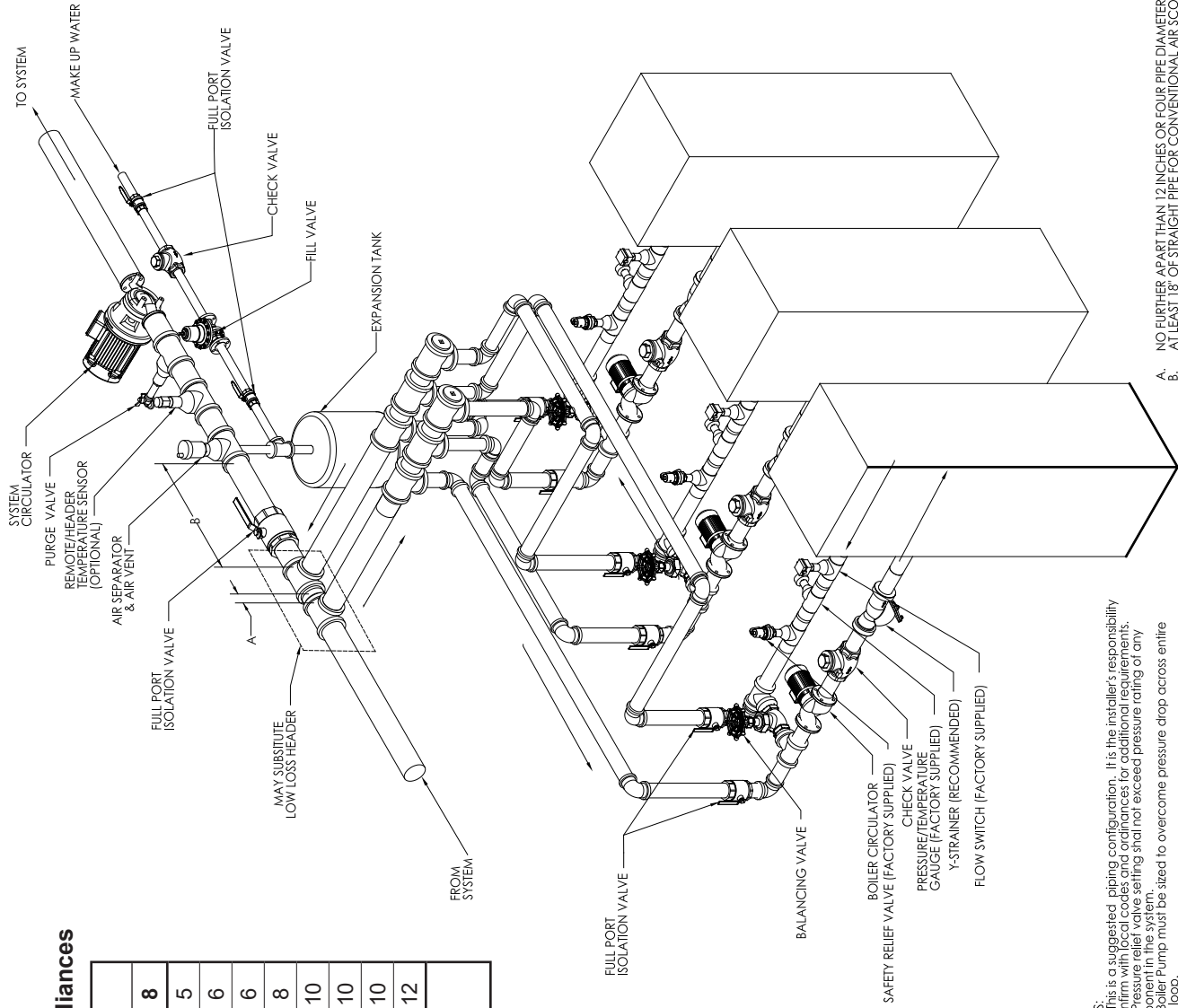
- NOTES:
1. This is a suggested piping configuration. It is the installer's responsibility to confirm with local codes and ordinances for additional requirements.
  2. Pressure relief valve setting shall not exceed pressure rating of any component in the system.
  3. Boiler Pump must be sized to overcome pressure drop across entire boiler loop.

**Figure 14: Near Boiler Water Piping (Multiple Boilers)**

**Required Common Pipe Size for Multiple Appliances**

Model Size	Number of Appliances							
	2	3	4	5	6	7	8	
500	2.5	3	4	4	4	5	5	
750	3	4	4	4	5	5	6	
1000	4	4	5	5	6	6	6	
1500	4	5	6	6	8	8	8	
2000	5	6	6	8	8	8	10	
2000S	5	6	6	8	8	8	10	
2500	5	6	8	8	10	10	10	
3000	5	8	8	10	10	10	12	

Note: Nominal pipe sizes are listed. Based on 20°F temperature rise.



NOTES:  
 1. This is a suggested piping configuration. It is the installer's responsibility to coordinate with the manufacturer for additional requirements.  
 2. Pressure relief valve setting shall not exceed pressure rating of any component in the system.  
 3. Boiler Pump must be sized to overcome pressure drop across entire boiler loop.

A. NO FURTHER APART THAN 12 INCHES OR FOUR PIPE DIAMETERS, WHICHEVER IS SMALLER.  
 B. AT LEAST 18" OF STRAIGHT PIPE FOR CONVENTIONAL AIR SCOOP.

**Figure 15: Multiple Boiler Water Piping with Common Header**

7. Electrical

- a. Each boiler must be provided with a dedicated fused disconnect.
- b. Install wiring and ground boiler in accordance with requirements of authority having jurisdiction. In absence of such requirements, reference the National Electrical Code, ANSI/NFPA 70 and/or CSA C22.1 Electrical Code.
- c. Refer to Figure 1 for electrical data for each size boiler.
- d. Refer to the Electrical section for further warnings, cautions, notices and instructions.

**NOTICE**

**Do not install boiler and circulator pump on the same fused disconnect.**

8. Condensate Piping

- a. Each boiler requires separate condensate drains. In addition, most venting configurations require separate condensate drains in the vent system.
- b. Refer to Section H for condensate removal system.

**B. CONDENSATE DRAINS**

- 1. Each boiler contains a condensate drain. In addition, most vent configurations require a drain tee located in the vent piping. Pipe each condensate drain separately to a floor drain or condensate pump/sump.
- 2. Use continuous Teflon, high temperature resistant silicone tubing, or other tubing material compatible with flue gas condensate, for condensate piping. Do not install valves on condensate drain lines.

**⚠ CAUTION**

**Failure to properly pipe condensate system will greatly reduce boiler life. Do not install plugs, caps or valves on condensate piping.**

**Do not manifold boiler condensate drains or vent drains together.**

**Do not crimp condensate lines or reduce drain line inner diameter size.**

**Each condensate drain must contain a siphon/pigtail or trap to prevent flue gas flow through the condensate piping. The height of the top of the syphon/pigtail loop or trap shall not exceed the height of the condensate drain outlet.**

- 3. A common condensate pump/sump may be used. Run separate piping from each condensate drain to the sump. A common drain may be used to discharge condensate from the sump. Consult pump/sump manufacturer for compatibility of pump/sump materials of construction. If a common sump is used, individual drain lines should be connected such that one drain cannot back feed into another drain.

- 4. Consult local authorities regarding disposal of flue gas condensate into public waste water system. Some jurisdictions require that the condensate be buffered before discharge. This buffering is commonly achieved by draining the condensate through a limestone (calcium carbonate) bed. The condensate will be slightly acidic and range between 3-5 on the pH scale. Consult Thermal Solutions or a chemical treatment company for buffering systems.

**⚠ CAUTION**

**Do not use material that is not approved for use with flue gas condensate for condensate piping.**

**⚠ ATTENTION**

**Le fait de ne pas monter correctement la tuyauterie du système de condensats va réduire fortement la durée de vie de la chaudière. Ne pas installer d'obturateurs, capuchons ou vannes dans les tuyauteries de condensats.**

**Ne pas relier ensemble les drains de condensats ou de ventilation de la chaudière**

**Ne pas pincer les tuyaux de condensats ou réduire la taille du diamètre interne du tuyau de vidange.**

**Chaque drain de condensats doit contenir un siphon/queue de cochon ou une trappe afin d'empêcher le débit des fumées de combustion dans la tuyauterie de condensats. La hauteur au sommet du siphon/queue de cochon ou de la trappe ne doit pas dépasser la hauteur de la sortie du drain de condensats.**

**⚠ ATTENTION**

**Ne pas utiliser pour la tuyauterie des condensats du matériel qui n'est pas approuvé pour une utilisation avec des condensats de fumées de combustion.**

## VIII. System Start-up

### NOTICE

Failure to properly pipe boiler may result in improper operation and damage to boiler or structure.

Oxygen contamination of boiler water will cause corrosion of iron and steel boiler components, and can lead to boiler failure. Thermal Solutions Standard Warranty does not cover problems caused by oxygen contamination of boiler water.

Proper water treatment is required to avoid scale build-up on the inside of the boiler. Thermal Solutions standard warranty does not cover problems caused by scale build-up.

All piping either new or existing must be cleaned with a tri sodium phosphate (TSP) solution to remove mill scale and oils from the system. Failure to do so could result in premature failure of the heat exchanger (not covered by Thermal Solutions warranty).

On an existing or retrofit system, a filter or strainer must be installed on the system return prior to the boilers.

When using Glycol products, all Glycol manufacturers' requirements, including rust inhibitors, must be adhered. Max 50% Glycol.

### A. System Checks

1. Verify that the venting, water piping, gas piping and electrical system are installed properly. Refer to installation instructions contained in this manual.

### ⚠ WARNING

Completely read, understand and follow all instructions in this manual, Honeywell flame safeguard, and all other component manuals supplied with this boiler before attempting start up.

2. Confirm all electrical, water and gas supplies are turned off at the source and that chimney/vent is clear of obstructions. If boiler is controlled by an external control system, this system must be temporarily disconnected. The local boiler controls should be allowed to operate the boiler.
3. Remove the upper front jacket panel.
4. Confirm that all manual shut-off gas valves between the boiler and gas supply are closed.

### ⚠ CAUTION

This boiler contains a manual gas shut-off valve inside of the upper front jacket panel.

### Pressurize the Hydronic System

5. fill entire heating system with water and vent air from system. Use the following procedure on a Series Loop or multi-zoned system installed to remove air from the system while filling.
6. Close full port ball valve in boiler supply piping.
7. Isolate all zones by closing zone valves or shut-off valves in supply and return of each zone(s).
8. Attach a hose to the hose bib in system piping and terminate hose in a five gallon bucket at a suitable floor drain or outside area.
9. Starting with one circuit at a time, open zone valve or shut-off valve in system supply and return piping.
  - a. Open hose bib.
  - b. Open fill valve (Make-up water line should be located directly after full port ball valve in system supply piping between air scoop and expansion tank).
  - c. Allow water to overflow from bucket until discharge from hose is bubble free for 30 seconds.
  - d. Close the opened zone valve or shut-off valve for the zone being purged of air, then open the zone valve or shut-off valve for the next zone to be purged. Repeat this step until all zones have been purged. At completion, open all zone valves or shut-off valves.
10. Close hose bib, continue filling the system until the pressure gauge indicates required system operating pressure. Close fill valve. (Note - if make-up water line is equipped with pressure reducing valve, system will automatically fill to set pressure. Follow fill valve manufacturer's instructions).
11. Open isolation valve in boiler supply piping.
12. Remove hose from hose bib.
13. Confirm that the boiler and system have no water leaks.

### **⚠ CAUTION**

**The maximum operating pressure of this boiler is 160 psig. Never exceed this pressure. This boiler was supplied with a pressure relief valve with a pressure relief setting specified at the time of purchase. The relief valve setting must be above the maximum operating pressure of the system. Consult Thermal Solutions if the desired system operating pressure is above the pressure relief valve pressure setting. Do not plug or change pressure relief valve.**

#### **Electrical Power to Boiler**

14. Turn on electrical supply to the boiler and circulation system at fused disconnect switches. Turn on control circuit breaker inside front jacket panel. Note that there is electrical power at certain components even with the boiler operating switch off. See wiring diagrams in Figures 9a-9c.

#### **Power the Circulators**

15. Turn system circulators on and purge air from the boiler and system piping.
16. Confirm motor rotation on boiler and system circulators.
17. Confirm that water flow switch is operating properly.

#### **Pressurize the Fuel System**

18. Turn on gas supply to the boiler gas piping.
19. Confirm that the supply pressure to the gas regulator supplied with the boiler conforms to Table 3 for maximum and minimum supply pressures.
20. Open the manual gas shut-off valves located upstream of the gas regulator supplied with the boiler. Do not open manual gas valve inside of boiler jacket.

### **⚠ DANGER**

**Do not use matches, candles, open flames or other ignition source to check for leaks.**

21. Using soap solution, or similar non-combustible solution, electronic leak detector or other approved method, check that boiler gas piping valves, regulators and all other components are leak free. Eliminate any leaks.
22. Purge gas line of air.
23. Reset low gas pressure safety switch.

#### **Check Blower Rotation**

24. Turn boiler operating switch to the on position
25. Remove air filter to expose the fan blades.

26. Allow boiler to enter the sequence of operation.
27. While in Pre-Purge, position the flame control to the test position.
28. Confirm proper blower motor rotation.
29. Shut boiler off and position the flame control back to run. Reinstall air filter.

#### **B. Flame Safeguard Operation Check**

1. Turn boiler operating switch to the on position.
2. Allow boiler to complete prepurge and trial for ignition period. Once pilot flame is recognized by controller, position flame control switch to test position.
3. Look through the boiler sight glass and confirm that pilot flame is blue and steady and that the flame signal is steady and between 1.5 and 5.0 volts DC. On some boiler sizes, the pilot flame may not be visible. In these cases, confirm proper flame signal (as indicated above.)
4. Adjust pilot gas regulator until proper pilot manifold gas pressure is achieved per firetest report label. Pilot flame should be blue with very little yellow.
5. Turn the boiler off, place flame control switch in "run" position, and repeat Steps H.1 and H.2 at least five times until reliable pilot ignition and signal is achieved and confirmed.
6. With the pilot operating properly, allow boiler to continue to trial for main flame. Confirm that the flame control locks out on main flame failure.
7. Open the manual main gas shut-off valve located inside the boiler jacket. Using the procedure detailed in Step E.3, leak test gas piping and valves upstream of the boiler main gas valve. Eliminate any leaks.
8. Reset flame safeguard and allow boiler to run through prepurge, trial for pilot and trial for main flame.
9. Confirm that main flame ignites smoothly.
10. Observe main flame and confirm that burner element is evenly orange without flickering.
11. Observe flame signal and confirm signal is steady and between 1.5 and 5.0 volts DC.
12. Using the procedure detailed in step E.3, leak test gas piping and valves downstream of the boiler gas valve. Eliminate any leaks.
13. Turn boiler off and repeat Steps H.7-H.10 at least five times to confirm proper main burner operation.

### C. Commissioning the Boiler

1. With main flame on, at high fire, measure gas pressure upstream and downstream of the main gas valves.
2. Adjust the manifold pressure to match the pressure indicated on the factory firetest label.
3. Ensure that the inlet gas pressure is within the acceptable range found in Table 3. Adjust if necessary.

#### **⚠ WARNING**

**Failure to properly adjust gas input rate will result in over firing or under firing of the appliance. Improper and unsafe boiler operation may result.**

4. Confirm that high and low gas pressure switches are functioning and are adjusted to prevent over firing or under firing of the boiler.
5. Adjust setting of air filter flow switch by rotating knob on switch counter clockwise until change filter light switch is illuminated. Turn switch knob clockwise ¼ turn past the point where the change filter light goes out. Replace upper front jacket panel.
6. With boiler running and all panels attached, measure oxygen (O<sub>2</sub>) and carbon monoxide (CO) concentrations in the flue gas and flue gas temperature. Compare results with factory fire test label/report.
7. Adjust gas valve if Air fuel ratio is outside of the ranges below.
  - a. The high fire O<sub>2</sub>% shall be between 4.0% and 6.0%. (8.5-9.6% CO<sub>2</sub> on NG, 9.8-11.6% CO<sub>2</sub> on LP)
  - b. The low fire O<sub>2</sub>% shall be between 5.5% and 7.0% (7.9-8.8% CO<sub>2</sub> on NG, 9.2-10.2% CO<sub>2</sub> on LP)

#### **⚠ DANGER**

**Failure to properly adjust excess air will result in unsafe levels of carbon monoxide. Variations in venting or combustion air pressure and temperature will change excess air. Adjust excess air levels so that variation in venting or combustion air pressures and temperatures caused by change of seasons, wind conditions, opening or closing of boiler room doors or windows do not cause the boiler to operate with carbon monoxide concentrations above 400 parts per million.**

8. Verify that all safety and operating limits and flame controls are operating properly. These controls and limits include combustion air switch, water temperature operating control, manual reset water temperature safety limit, vestibule fuseable link, mixer fuseable link, high and low gas pressure switches. Refer to manuals for these components for proper start-up and operating instructions. Follow all instructions contained in these manuals. This manual was provided with the boiler.

### D. Finish Commissioning the Boiler

1. Reconnect any wires from the external control system, if applicable.
2. Test function of external control system.
3. Place system control back in normal operation, if necessary.

### E. Water Treatment

1. Contact reputable chemical treatment company for recommendations on proper water treatment for the installation. Each installation is different and must be analyzed based on local water conditions and boiler operating schedule.
2. The treatment chemicals must be compatible with copper, bronze, steel and cast iron materials of construction.

#### **NOTICE**

**A proper water treatment and a monitoring program will extend the life of the boiler. The water shall have a maximum water hardness of 8.5 grains or 150 ppm. The recommended pH range is 8.8 to 9.2. However, other aspects of water quality can affect boiler operation and longevity. A qualified water treatment expert should be consulted to develop a complete water treatment plan.**

#### **⚠ WARNING**

**Chemicals used in treating boiler water are toxic and/or harmful. Always use protective clothing and equipment when working with/near chemicals. Contact local authorities to determine if treated boiler water can be discharged into local waste water system.**

## System Start-up Warnings - French

### AVIS

Tout non-respect dans le montage correct de la tuyauterie de la chaudière peut résulter en un fonctionnement incorrect et des dommages à la chaudière ou à la structure.

La contamination par l'oxygène de l'eau de la chaudière va provoquer la corrosion des composants en fer et en acier de la chaudière et peut conduire à la défaillance de la chaudière. La garantie standard de Thermal Solutions ne couvre pas les problèmes causés par la contamination par l'oxygène de l'eau de la chaudière.

Un traitement correct de l'eau est exigé afin d'éviter le dépôt de calcaire à l'intérieur de la chaudière. La garantie standard de Thermal Solutions ne couvre pas les problèmes causés par le dépôt de calcaire.

Toute tuyauterie soit neuve, soit existante doit être nettoyée avec une solution de phosphate trisodique (TSP) afin d'éliminer les incrustations et les huiles du système. Le non-respect de cette procédure pourrait conduire à une défaillance prématurée de l'échangeur de chaleur (non couverte par la garantie standard par Thermal Solutions).

Sur un système existant ou rénové, un filtre ou un tamis doit être installé sur le retour du système avant les chaudières.

Lors de l'utilisation de produits Glycol, toutes les exigences des fabricants de Glycol, incluant les inhibiteurs de rouille, doivent être respectées. Max 50% de Glycol.

### ⚠ AVERTISSEMENT

Lire, comprendre et suivre complètement toutes les instructions dans ce manuel, le contrôle de la flamme Honeywell et tous les autres manuels de composants fournis avec cette chaudière avant d'essayer la mise en service.

### ⚠ ATTENTION

Cette chaudière comporte une vanne de fermeture manuelle à l'intérieur du panneau supérieur de la chemise avant.

### AVIS

Un traitement correct de l'eau et un programme de surveillance augmenteront la durée de vie de la chaudière. L'eau doit avoir une dureté maximale de 8,5 grains ou 150 ppm. La plage de pH recommandée est 8,8 à 9,2. Cependant, d'autres aspects de la qualité de l'eau peuvent affecter la longévité et le fonctionnement de la chaudière. Un expert qualifié en traitement de l'eau devra être consulté afin de développer un plan complet du traitement de l'eau.

### ⚠ AVERTISSEMENT

Les produits chimiques utilisés pour le traitement de l'eau de la chaudière sont toxiques et/ou nocifs. Utiliser toujours un équipement et des vêtements de protection lors de tout travail avec ou à proximité de produits chimiques. Prendre contact avec les autorités locales afin de déterminer si l'eau de traitement de la chaudière peut être déversée dans le système local des eaux usées.

### ⚠ AVERTISSEMENT

La pression maximale de fonctionnement de cette chaudière est de 11,2 bars (160 psig). Ne jamais dépasser cette pression. Cette chaudière a été fournie avec une soupape de sécurité avec un réglage de limitation de pression spécifié au moment de l'achat. Le réglage de limitation de pression doit être supérieur à la pression maximale de fonctionnement du système. Consulter Thermal Solutions si la pression désirée maximale de fonctionnement du système est au-dessus du réglage de la pression de la soupape de sécurité. Ne pas boucher ou changer la soupape de sécurité.

### ⚠ DANGER

Ne pas utiliser d'allumettes, bougies, flamme nue ou autre source d'allumage pour rechercher des fuites.

### ⚠ AVERTISSEMENT

Tout non-respect dans un réglage correct du taux d'entrée de gaz va résulter en une surchauffe ou une chauffe insuffisante de l'appareil. Un fonctionnement incorrect et dangereux peut en résulter.

### ⚠ DANGER

Tout non-respect dans le réglage correct de l'excès d'air résultera en des niveaux dangereux de monoxyde de carbone. Des variations de la ventilation ou de la pression d'air de combustion et de la température changeront l'excès d'air. Régler les niveaux de l'excès d'air de façon que la variation de ventilation ou des pressions et température de l'air de combustion causée par le changement de saisons, les coups de vent, l'ouverture ou la fermeture des portes ou fenêtres de la pièce de la chaudière, ne soit pas la cause d'un fonctionnement de la chaudière avec des concentrations en monoxyde de carbone supérieures à 400 parts par million.

**FOR YOUR SAFETY READ BEFORE OPERATING/P OUR VOTRE  
SÉCURITÉ LISEZ AVANT DE METTRE EN MARCHÉ**

**WARNING:** If you do not follow these instructions exactly, a fire or explosion may result causing property damage, personal injury or loss of life.

**AVERTISSEMENT:** Quiconque ne respecte pas à la lettre les instructions dans la présente notice risque de déclencher un incendie ou une explosion entraînant des dommages, des blessures ou la mort.

A. This appliance does not have a pilot. It is equipped with an ignition device which automatically lights the burner.

Do not try to light the burner by hand.

B. BEFORE OPERATING smell all around the appliance area for gas. Be sure to smell next to the floor because some gas is heavier than air and will settle on the floor.

**WHAT TO DO IF YOU SMELL GAS:**

- Do not try to light any appliance.
- Do not touch any electric switch; do not use any phone in your building.
- Immediately call your gas supplier from a neighbor's phone. Follow the gas supplier's instructions.
- If you cannot reach your gas supplier, call the fire department.

C. Use only your hand to turn the gas control knob.

Never use tools. If the knob will not turn by hand, don't try to repair it, call a qualified service technician. Force or attempted repair may result in a fire or explosion.

D. Do not use this appliance if any part has been under water. Immediately call a qualified service technician to inspect the appliance and to replace any part of the control system and any gas control which has been under water.

A. Cet appareil ne comporte pas de veilleuse. Il est muni d'un dispositif d'allumage qui allume automatiquement le brûleur. Ne tentez pas d'allumer le brûleur manuellement.

B. AVANT DE FAIRE FONCTIONNER, reniflez tout autour de l'appareil pour déceler une odeur de gaz. Reniflez près du plancher, car certains gaz sont plus lourds que l'air et peuvent s'accumuler au niveau du sol.

**QUE FAIRE SI VOUS SENTEZ UNE ODEUR DE GAZ:**

- Ne pas tenter d'allumer d'appareil.
- Ne touchez à aucun interrupteur ; ne pas vous servir des téléphones se trouvant dans le bâtiment.
- Appelez immédiatement votre fournisseur de gaz depuis un voisin. Suivez les instructions du fournisseur.
- Si vous ne pouvez rejoindre le fournisseur, appelez le service des incendies.

C. Ne poussez ou tournez la manette d'admission du gaz qu'à la main ; ne jamais utiliser d'outil. Si la manette reste coincée, ne pas tenter de la réparer ; appelez un technicien qualifié. Le fait de forcer la manette ou de la réparer peut déclencher une explosion ou un incendie.

D. N'utilisez pas cet appareil s'il a été plongé dans l'eau, même partiellement. Faites inspecter l'appareil par un technicien qualifié et remplacez toute partie du système de contrôle et toute commande qui ont été plongés dans l'eau.

**OPERATING INSTRUCTIONS/ INSTRUCTIONS DE FONCTIONNEMENT**

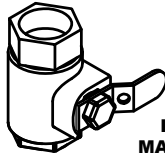
1. STOP! Read safety information above on this label.
2. Set the thermostat to lowest setting.
3. Turn off all electric power to the appliance.
4. This appliance is equipped with an ignition device which automatically lights the burner. Do not try to light the burner by hand.
5. Turn the external boiler manual gas valve handle clockwise ↻ to close the gas supply.
6. Wait five (5) minutes to clear out any gas. Then smell for gas, including near the floor. If you smell gas, STOP! Follow "B" in the safety information above on this label. If you don't smell gas, go to the next step.
7. Turn the external boiler manual gas valve handle counterclockwise ↺ to open the gas supply.
8. Turn on all electric power to the appliance.
9. Set the thermostat to the desired setting.
10. If the appliance will not operate, follow the instructions "To Turn Off Gas To Appliance" and call your service technician or gas supplier.

1. ARRÊTEZ ! Lisez les instructions de sécurité sur la portion supérieure cette étiquette.
2. Réglez le thermostat à la température la plus basse.
3. Coupez l'alimentation électrique de l'appareil.
4. Cet appareil est équipé de l' dispositif d'allumage qui automobile allume matiquement le brûleur. Ne tentez pas d'allumer le brûleur manuellement.
5. Tourner la chaudière externe manuelle poignée ↻ en clapet à gaz dans le sens des aiguilles d'une montre pour fermer l'offre de gaz.
6. Attendre cinq (5) minutes pour laisser échapper tout le gaz. Reniflez tout autour de l'appareil, y compris près du plancher, pour déceler une odeur de gaz. Si vous seutez une odeur de gaz, ARRÊTEZ ! Passez à l'étape B des instructions de sécurité sur la portion supérieure de cette étiquette. S'il n'y a pas d'odeur de gaz, passez à l'étape suivante.
7. Tourner la chaudière externe manuelle compteur de poignée ↺ en clapet à gaz ouvrir dans le sens des aiguilles d'une montre le gaz approvisionnement.
8. Mettez l'appareil sous tension.
9. Réglez le thermostat à la température désirée.
10. Si l'appareil ne se met pas en marche, suivez les instructions intitulées « Comment couper l'admission de gaz de l'appareil » et appelez un technicien qualifié ou le fournisseur de gaz.

**OPEN/OUVERT**



**CLOSED/FERMÉ**



**EXTERNAL BOILER  
MANUAL GAS VALVE  
LA CHAUDIÈRE EXTERNE  
MANUELLE DE CLAPET À GAZ**

**TO TURN OFF GAS TO APPLIANCE/ COMMENT COUPER L'ADMISSION DE GAZ  
DE L'APPAREIL**

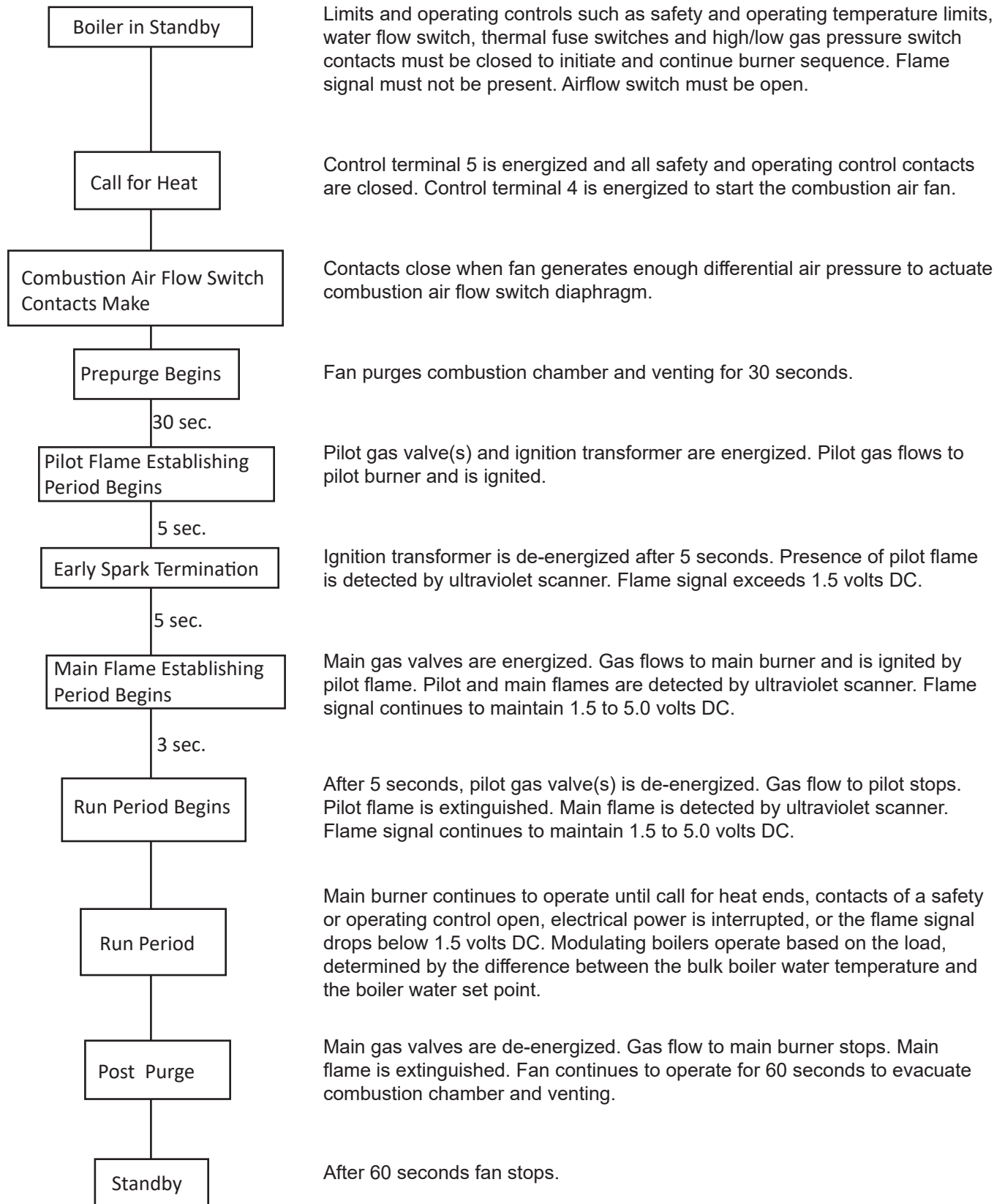
1. Set the thermostat to lowest setting.
2. Turn off all electric power to the appliance if service is to be performed.
3. Turn the external boiler manual gas valve handle clockwise ↻ to close gas supply.

1. Réglez le thermostat à la température la plus basse.
2. Coupez l'alimentation électrique de l'appareil s'il faut procéder à l'entretien.
3. Tourner la chaudière externe manuelle poignée ↻ en clapet à gaz dans le sens des aiguilles d'une montre pour fermer l'offre de gaz.

101607-03

# IX. Boiler Operational Sequence

## NORMAL SEQUENCE OF OPERATION



## X. Service/Maintenance

### **⚠ DANGER**

This boiler uses flammable gas, high voltage electricity, moving parts, and very hot water under high pressure. Assure that all gas and electric power supplies are off and that the water temperature is cool before attempting any disassembly or service.

More than one gas shut-off valve and electrical disconnect switch are used on the boiler. Assure that all gas valves and electrical disconnect switches are off before attempting any disassembly or service.

Do not attempt any service work if gas is present in the air in the vicinity of the boiler.

Never modify, remove or tamper with any control device.

### **⚠ WARNING**

This boiler must only be serviced and repaired by skilled and experienced service technicians.

If any controls are replaced, they must be replaced with identical models.

Read, understand and follow all the instructions and warnings contained in all the sections of this manual.

If any electrical wires are disconnected during service, clearly label the wires and ensure that the wires are reconnected properly.

Never jump out or bypass any safety or operating control or component of this boiler.

Do not attempt to remove and/or service the burner. This may result in damage to the burner.

Read, understand and follow all the instructions and warnings contained in ALL of the component instruction manuals.

Assure that all safety and operating controls and components are operating properly before placing the boiler back in service.

### **⚠ CAUTION**

USE caution when servicing components behind upper front jacket panel. Filter/mounting bracket may cause head injury.

### **⚠ WARNING**

The service instructions contained in this manual are in addition to the instructions provided by the manufacturer of the boiler components. Follow component manufacturer's instructions. Component manufacturer's instructions were provided with the boiler. Contact component manufacturer for replacement if instructions are missing. Do not install, start up, operate, maintain or service this boiler without reading and understanding all of the component instructions. Do not allow the boiler to operate with altered, disconnected or jumpered components. Only use replacement components identical to those originally supplied by Thermal Solutions.

**⚠ DANGER**

Cette chaudière utilise du gaz inflammable, de l'électricité haute tension, des pièces mobiles, et de l'eau très chaude sous haute pression. S'assurer que toutes les alimentations en gaz et électriques sont coupées et que la température de l'eau est basse avant d'essayer tout démontage ou entretien.

Cette chaudière comporte plus qu'une vanne d'arrêt de gaz et d'interrupteur électrique. S'assurer que toutes les vannes de gaz et commandes des interrupteurs électriques sont sur arrêt avant d'essayer tout démontage ou entretien.

Ne pas entreprendre tout travail d'entretien si du gaz est présent dans l'air à proximité de la chaudière.  
Ne jamais modifier, ôter ou trafiquer tout dispositif de commande.

**⚠ AVERTISSEMENT**

Cette chaudière doit être entretenue et réparée seulement par des techniciens de service compétents et expérimentés.

Si des commandes sont remplacées, elles doivent être remplacées par des modèles identiques.

Lire, comprendre et suivre toutes les instructions et avertissements contenus dans l'ensemble des sections de ce manuel.

En cas de déconnexion de fils électriques lors de l'entretien, étiqueter clairement les fils et s'assurer que les fils sont reconnectés correctement.

Ne jamais court-circuiter ou contourner toute commande ou composant de sécurité ou de fonctionnement de cette chaudière.

Ne pas essayer de retirer et/ou entretenir le brûleur. Ceci peut résulter en un endommagement du brûleur.

Lire, comprendre et suivre toutes les instructions et avertissements contenus dans TOUTES les sections des manuels d'instructions des composants.

S'assurer que toutes les commandes et composants de fonctionnement et de sécurité fonctionnent correctement avant de remettre la chaudière en service.

**⚠ ATTENTION**

**FAIRE PREUVE DE PRUDENCE** lors de l'entretien de composants situés derrière le panneau supérieur avant de la chemise. Le filtre/support de montage peut causer des blessures à la tête.

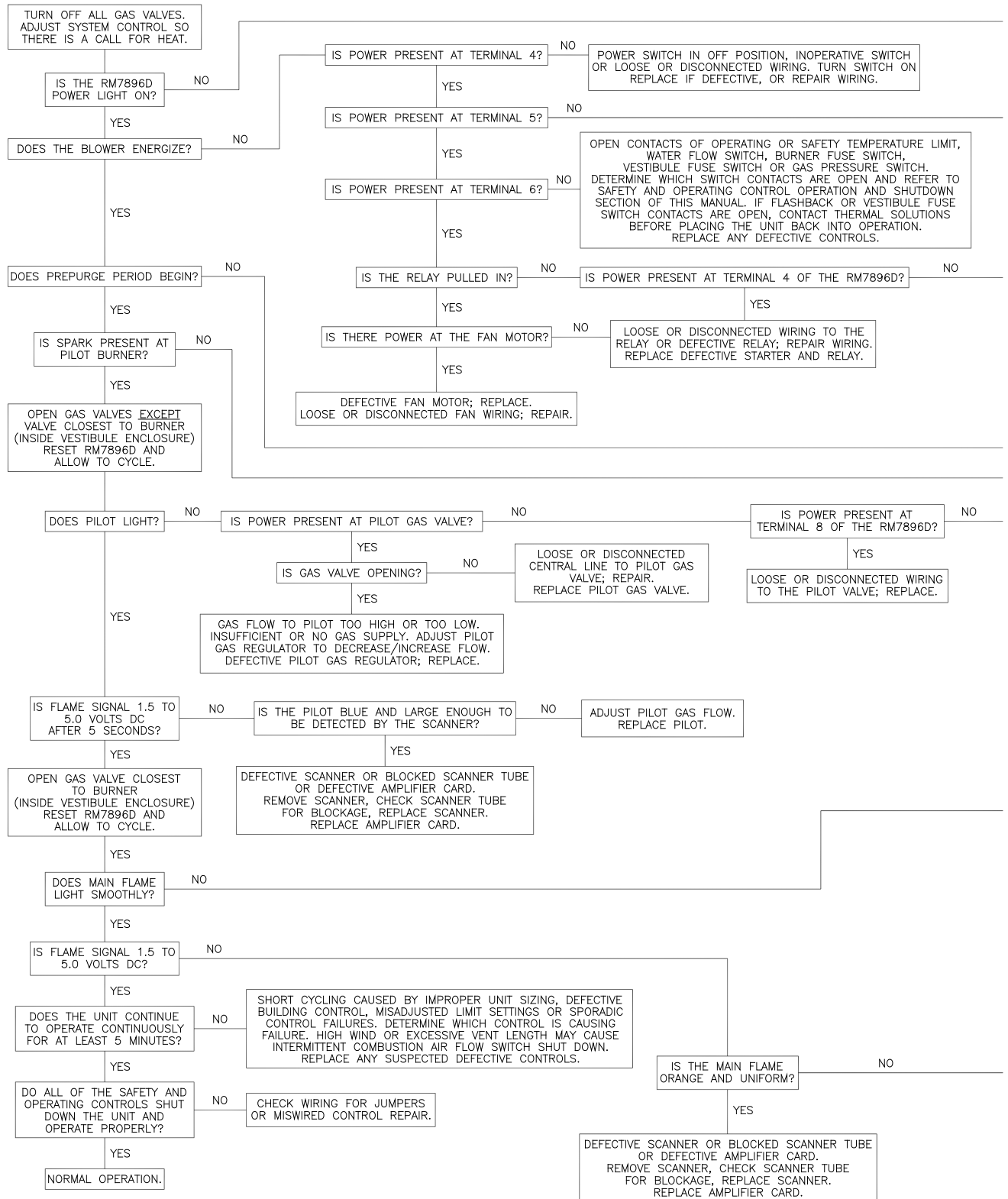
**⚠ AVERTISSEMENT**

Les instructions d'entretien contenues dans ce manuel viennent en addition aux instructions fournies par le fabricant des composants de la chaudière. Suivre les instructions données par le fabricant des composants. Les instructions du fabricant des composants sont fournies avec la chaudière. Prendre contact avec le fabricant des composants pour obtenir les instructions manquantes. Ne pas installer, mettre en service, faire fonctionner, réaliser la maintenance ou l'entretien de cette chaudière sans avoir lu et ompris l'ensemble des instructions de composants. Ne pas autoriser le fonctionnement de la chaudière avec des composants dégradés, déconnectés ou court-circuités. Utiliser seulement des composants de rechange identiques à ceux fournis à l'origine par Thermal Solutions.

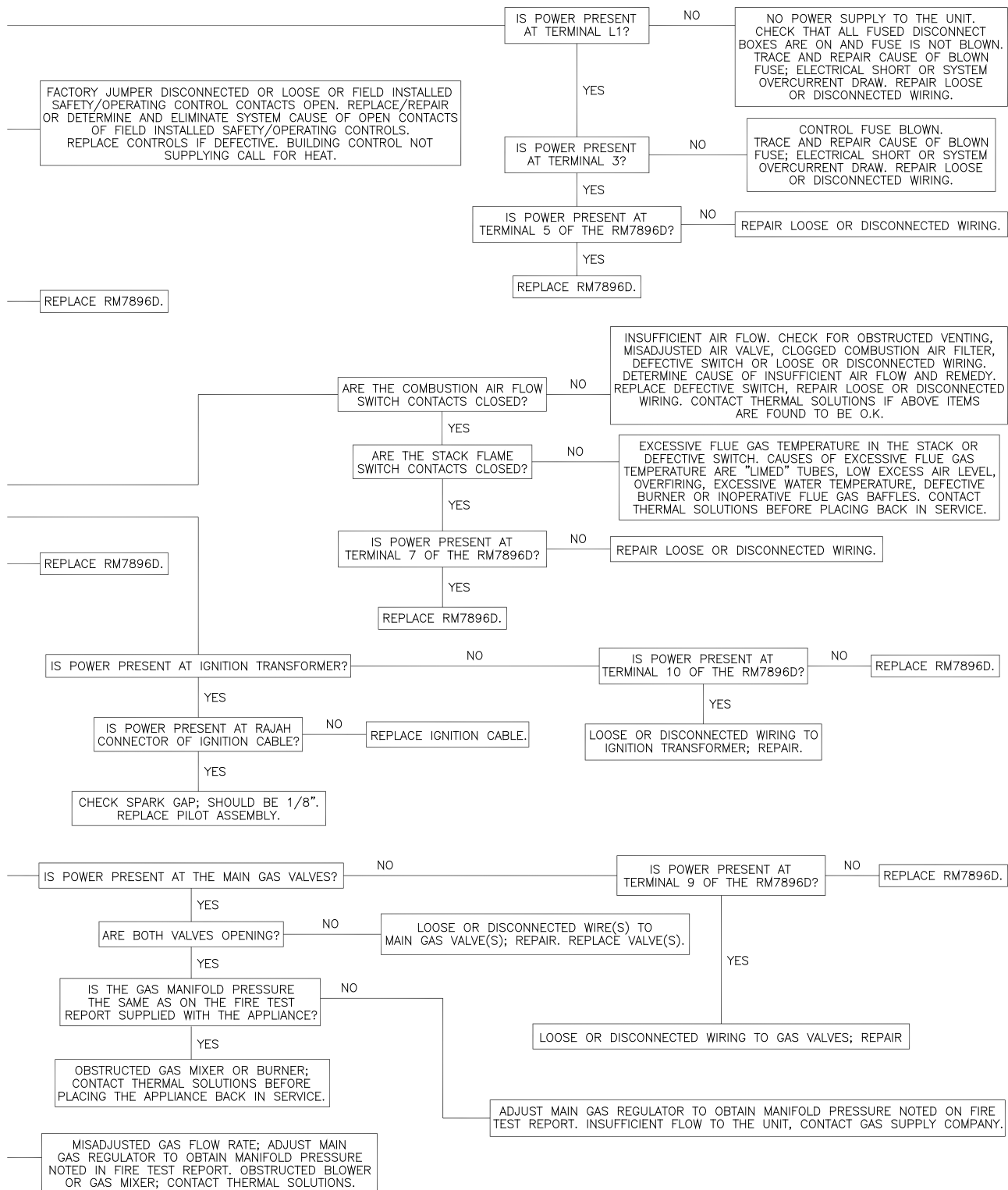
## A. Safety Controls, Operation, and Shut Down

COMPONENT	FUNCTION
<b>Control Circuit Breaker</b>	If the power draw of the control circuit exceeds approximately 5 amps, the circuit breaker trips and prevents the boiler from powering until circuit breaker is reset.
<b>Power Switch</b>	If this switch is in the off position, power is interrupted to the control circuit of the boiler which prevents the boiler from operating. If the switch is in the on position, power is supplied to the control circuit.
<b>Operating Aquastat</b>	If the boiler water temperature exceeds the adjustable set point, power is interrupted to the control circuit of the boiler which prevents the boiler from operating. When the boiler water temperature drops below the set point minus the adjustable differential setting, power is again supplied to the control circuit.
<b>Manual Reset High Limit Aquastat</b>	If the boiler water temperature exceeds the adjustable set point, power is interrupted to the control circuit of the boiler which prevents the boiler from operating. Power is interrupted until the control is manually reset by pressing the control's reset button. When the button is depressed, power will again be supplied to the control circuit.
<b>Flow Switch</b>	If the water flow through the boiler drops below the fixed flow rate required to move the control's paddle enough to close the controls contacts, power is interrupted to the control circuit, which prevents the boiler from operating. When the water flow rate is increased, the paddle closes the control's contacts and power is supplied to the control circuit.
<b>Pressure (Safety) Relief Valve</b>	If the pressure inside the appliance exceeds the fixed set point, the valve opens mechanically and discharges water. The valve remains open until the pressure inside the appliance drops below the set point.
<b>Mixer Fuseable Link</b>	If the temperature in the interior of the burner exceeds the fixed set point, the contacts of the switch open and power is interrupted to the control circuit which prevents the boiler from operating. Power is interrupted until the switch is replaced.
<b>Vestibule Fuseable Link</b>	If the temperature in the interior of the vestibule enclosure exceeds the fixed set point, the contacts of the switch open and power is interrupted to the control circuit which prevents the boiler from operating. Power is interrupted until the switch is replaced.
<b>High and Low Gas Pressure Switches</b>	If the gas pressure reaches a point below the adjustable set point, or above the adjustable set point, the contacts of the switch open and power is interrupted to the control circuit which prevents the boiler from operating. Power is interrupted until gas pressure is between the high and low set points and the control is manually reset by moving the switch to the reset position. The switches will not reset until the gas pressure is within the set point parameters.
<b>Combustion Air Flow Switch</b>	If the differential air pressure drops below the fixed set point, the contacts of the switch open and power is interrupted to the control circuit, which prevents the boiler from operating. Power is interrupted until air flow increases so that the contacts close.
<b>Flame Safeguard Control</b>	Refer to the manual supplied with the boiler.
<b>Variable Frequency Drive (VFD)</b>	The variable frequency drive's primary function is to vary the rotational speed of the blower fan based on the air requirements of the boiler combustion process. The VFD is used for Modulating boilers. The VFD responds to a 4-20 mA signal from the Digital Temperature Controller.
<b>Digital Temperature Controller</b>	The microprocessor based temperature controller is used on all modulating boilers. The controller's basic function is to control the firing rate of the boiler based on the difference between the bulk boiler water temperature and the controller's set-point. The controller also has the ability to change the operating set-point based on an external signal (contact closure for reduced demand setting or outdoor reset.)

## B. Troubleshooting Guide



## Troubleshooting Guide



**NOTICE**

BEFORE REPLACING RM7896D, CONFIRM THAT ALL THE WIRING TO THE SUB-BASE IS SECURE AND THAT THE SUB-BASE CONTROLS ARE NOT BENT TO THE REAR.

### C. Periodic Maintenance/Service List

Frequency	Component/Item	Recommended Test
<b>Daily Maintenance</b>	Boiler surroundings Gauges, monitors, and indicators Combustion Properties Burner flame Low Draft, fan air pressure, and damper position interlocks	Inspect the area to assure proper clearance to combustible materials, gasoline, and other flammable vapors and liquids. Make visual inspection and record readings.  Check combustion properties as specified in section VII, part D. Make visual inspection of burner flame as stated in section VII, part D.  Test low draft, fan, air pressure, and damper position interlocks according to instructions if so equipped.
<b>Weekly Maintenance</b>	Igniter Flame signal strength Flame failure detection system Firing rate control Pilot and/or main fuel valves Low-water fuel cutoff	Make visual inspection, check flame signal strength; log. Read and log flame signal meter, read for both pilot and main flames. Close manual fuel supply for (1) pilot, (2) main fuel cock, and/or valve(s); check safety shutdown timing. Refer to section VII, Part D. Check firing rate control, place RWF 40 in manual mode and check high and low firing settings for proper operation. Open limit switch and make aural and visual check; check valve position indicators and check fuel meters if so fitted. Test low-water fuel cutoff device and alarm according to manufacturer's instructions.
<b>Monthly Maintenance</b>	Flue, vent, stack, condensate drains, and outlet dampers Gas pressure interlocks Water condition	Confirm that components are gas tight and free from obstructions to flow. Test high and low gas pressure interlocks. Test condition of water, correct condition as needed.
<b>Semi-Annual Maintenance</b>	Gauges, monitors, and indicators Flame failure detection system Condensate drain tubes Air filter Interlocks and valves Circulators and system pumps	Recalibrate all indicating and recording gauges. Check components. Check drain tubes have liquid in trap and condensate is properly directed. Check air filter as specified in section VII, Part D. Check piping and wiring of all interlocks and shut off valves if so equipped. Maintain according to manufacturers' instructions.
<b>Annual Maintenance</b>	Flue, vent, stack, or outlet dampers Combustion Properties Flame failure detection system Pilot and/or main fuel valves Pilot and/or main fuel valves Flame safeguard Air Filter Boiler trim High limit and operating temp. controls	Confirm that components are gas tight and free from obstructions to flow. Check combustion properties as specified in section IV, Part I, Step 5. Conduct pilot turndown test according to manufacturer's instructions. This test is required annually and after any adjustments to flame scanner mount or pilot burner. Check all coils and diaphragms; test other operating parts of all safety shutoff and control valves. Perform leakage test on pilot and main gas and/or oil fuel valves, in accordance with instructions. Test purge timing according to manufacturer's instructions. Replace. Remove lower front jacket panel and check for any signs of corrosion and leaks. Test proper operation.
<b>As-Required</b>	Low-water fuel cutoff Pressure relief valves	Recondition or replace. Test pressure relief valves in accordance with ASME Boiler and Pressure Vessel Code, Sections VI and VII.

## D. Inspection and Cleaning Procedures

### Air Filter:

1. Perform a visual inspection of air filter and replace as necessary.
  - a. Remove upper front panel.
  - b. Remove red tube from nipple on filter assembly.
  - c. Remove wing nut.
  - d. Remove filter assembly from boiler. Remove the blower filter front plate, if necessary.
  - e. Remove foam pre-filter and wash with soap and water.
  - f. Replace primary filter as necessary.

### Pilot Flame:

2. Perform a visual inspection of pilot burner flame.
  - a. Refer to the flame safeguard instruction manual and conduct a pilot turndown test.
  - b. Observe pilot operation and record pilot signal. Flame should be steady medium hard blue clearly visible through sight glass.
3. Pilot Cleaning and Maintenance
  - a. Shut off gas supply and disconnect electrical service.
  - b. Disconnect scanner, ignition electrode, loosen and remove pilot gas line and combustion air line from fan.
  - c. Remove mounting fasteners and pull pilot assembly from heat exchanger.
  - d. Examine pilot electrode and set gap to 1/8" if needed. Clean as required.
  - e. Reassemble in reverse order using a new gasket available from Thermal Solutions.

### Burner Flame:

4. Perform a visual inspection of main burner flame.
  - a. Observe main flame and record flame signal. Flame should be steady deep orange in color with dark blue checkerboard pattern throughout.
  - b. Main burner requires no cleaning or annual maintenance

### Main Burner:

5. When properly maintained and operated the burner does not require servicing.

#### **⚠ CAUTION**

**Do not attempt to remove or service burner. Damage to the burner may result. Consult boiler manufacturer.**

#### **⚠ CAUTION**

**When the air filter is not properly maintained, the burner is susceptible of clogging. Check manifold pressure during the purge cycle to test for clogging.**

- a. Install a pressure fitting in the tapping on the gas manifold valve inside the boiler.
- b. Attach a pressure monitoring device to the pressure fitting.
- c. Check the pressure while the boiler is in the purge sequence.
- d. If the measured pressure is considerably higher than expected, consult factory.

### Check Combustion and Safety Controls:

6. Check flame failure detection system with system operating.
7. Pilot
  - a. Refer to the flame safeguard instruction manual.
  - b. Manually close pilot fuel supply and verify lock out of primary control.
8. Main Flame
  - a. Refer to the flame safeguard instruction.
  - b. Close manual main fuel shut off valve and verify lockout of primary control.

### Check Heat Exchanger:

9. Remove lower front jacket panel and check for any signs of corrosion and leaks.
10. Remove pipe plugs in header and inspect inside of copper tubes and header.
11. Flush boiler and mechanically remove any scale.

#### **⚠ ATTENTION**

**Ne pas essayer de retirer ou entretenir le brûleur. Tout dommage au brûleur peut en résulter. Consulter le fabricant de la chaudière.**

---

## **XI. Repair Parts**

---

EVA Series repair parts can be ordered through your nearest Thermal Solutions Representative for delivery from Lancaster, PA.

The Representatives can also advise as to the availability of product and repair parts from local sources. Contact Thermal Solutions for your Representative at:  
Thermal Solutions Products LLC

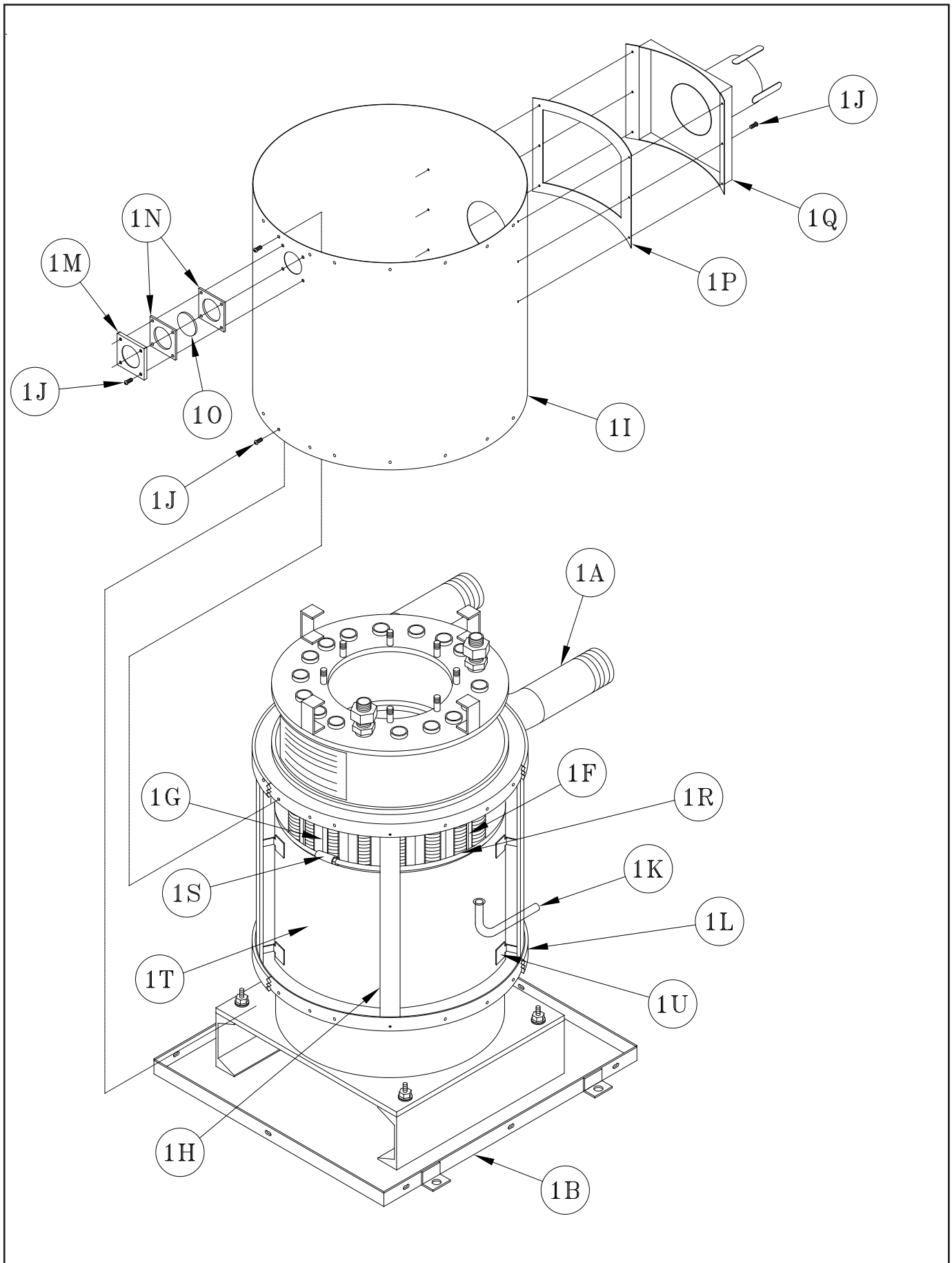
1175 Manheim Pike  
Lancaster, Pennsylvania 17601  
Telephone (717) 239-7642  
Fax (877) 501-5212 (toll free)  
www.thermalsolutions.com

### **NOTICE**

**The repair parts noted in this section are for a standard EVA Series boiler. Different contents and components may have been supplied due to the request of the equipment end user. Consult Thermal Solutions for repair parts on non-standard controls and components.**

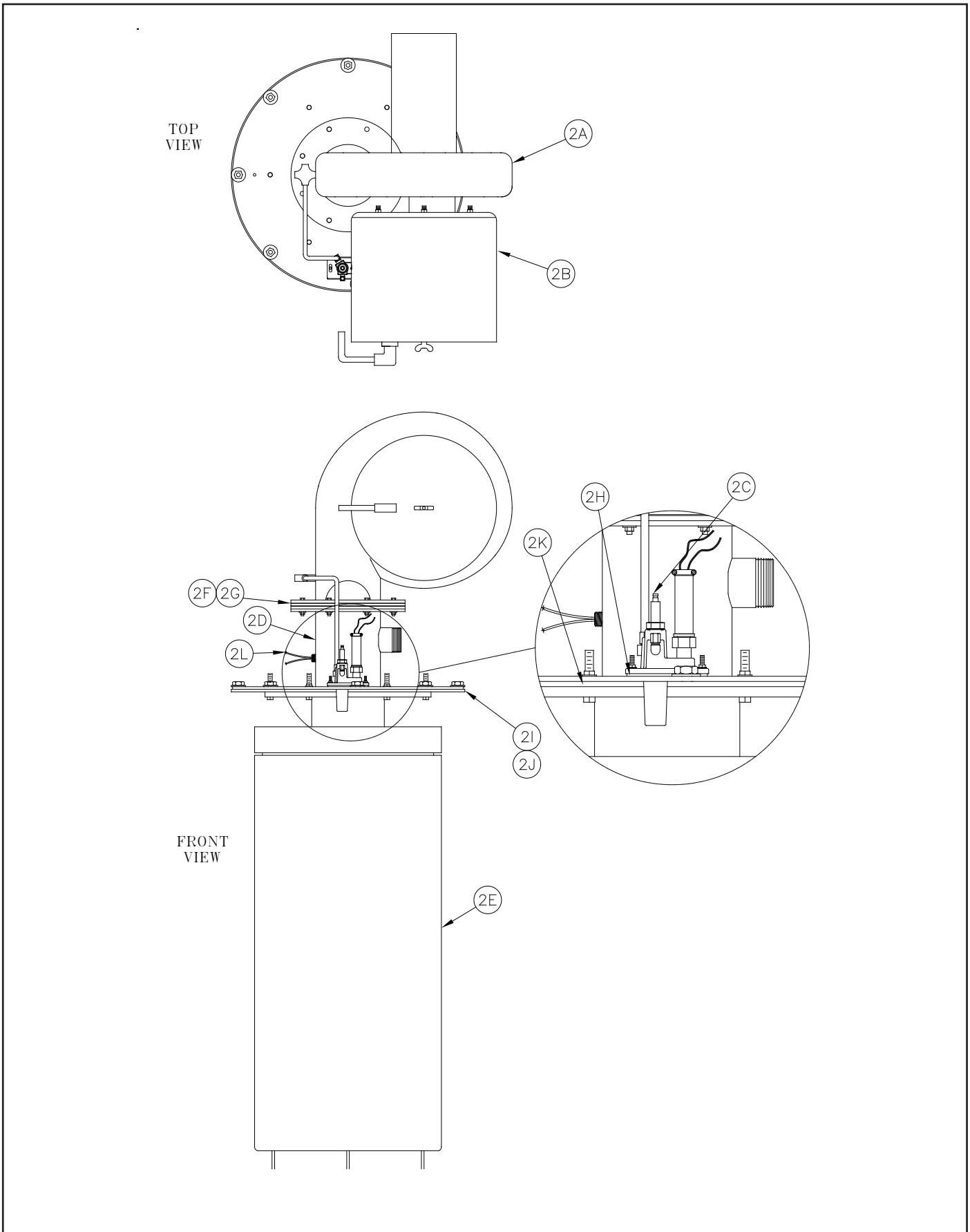
### **AVIS**

**Les pièces de rechange mentionnées dans cette section concernent la chaudière standard de la série EV. Différents contenus et composants peuvent avoir été fournis dus à la demande de l'utilisateur final de l'équipement. Consulter Thermal Solutions pour les pièces de rechange ou des composants et commandes non-standards.**



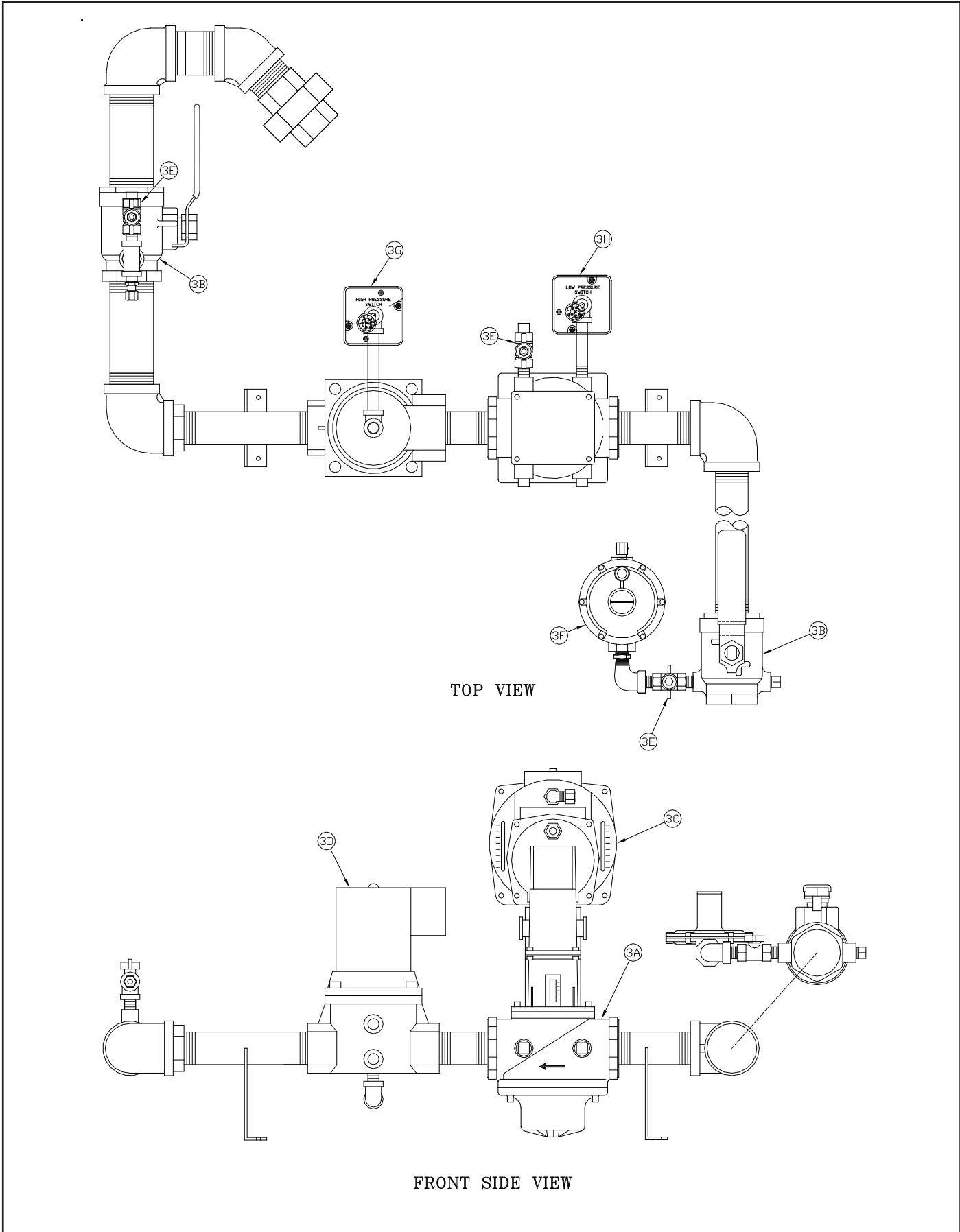
**Figure 19: Combustion Chamber Assembly**

COMBUSTION CHAMBER ASSEMBLY										
Key No.	Description	(Quantity) Part Number								
		EVA-500	EVA-750	EVA-1000	EVA-1500	EVA-2000	EVA-2000S	EVA-2500	EVA-3000	
1. COMBUSTION CHAMBER ASSEMBLY										
1A	Heat Exchanger with Wrapper	6185605002	6185607508	6185610008	6185615008	6185620009	61856200082	6185625002	6185630002	
1B	Base	(1) 61556042	(1) 61556024							
1F	Tube Baffle	(17) 70356116	(31) 70356215	(31) 70356216	(31) 70356217	(31) 70356218	(41) 70356315	(41) 70356316	(41) 70356317	
1G	Sight Tube Baffle	(1) 70356122	(1) 70356233	(1) 70356224	(1) 70356225	(1) 70356226	(1) 70356318	(1) 70356319	(1) 70356320	
1H	Combustion Pan Support	(4) 603561061	(4) 603562041	(4) 603562051	(4) 603562061	(4) 603562071	(6) 60356208	(6) 60356209	(6) 60356210	
1I	Heat Exchanger Wrapper	(1) 70356119	(1) 70356219	(1) 70356220	(1) 70356221	(1) 70356222	(1) 70356246	(1) 70356247	(1) 70356248	
1J	Heat Exchange Baffle	(1) 70356235	(1) 70356236	(1) 70356237	(1) 70356238	(1) 70356239	(1) 70356240	(1) 70356241	(1) 70356242	
1L	1" Fiber Gasket	(9 LF) 9206032	(14 LF) 9206032							
1M,N,O	Sight Glass Lens, Retainer, and Gaskets	113567-01 (kit)								
1M	Sight Glass Lens Retainer	(1) 7186019	(1) 7186019							
1N	Sight Glass Gaskets	(2) 8206039	(2) 8206039							
1O	Sight Glass Lens	(1) 8026082	(1) 8026082							
1P	Vent Connector Gasket	(1) 8205623	(1) 8205624							
1Q	Vent Connector	(1) 81156027	(1) 81156016	(1) 81156017		(1) 81156028	(1) 81156029	(1) 81156029		
1R	Wrapper Banding	(12 LF) 92466028	(24 LF) 92466028							
1S	Banding Buckle	(3) 80860946	(4) 80860946							



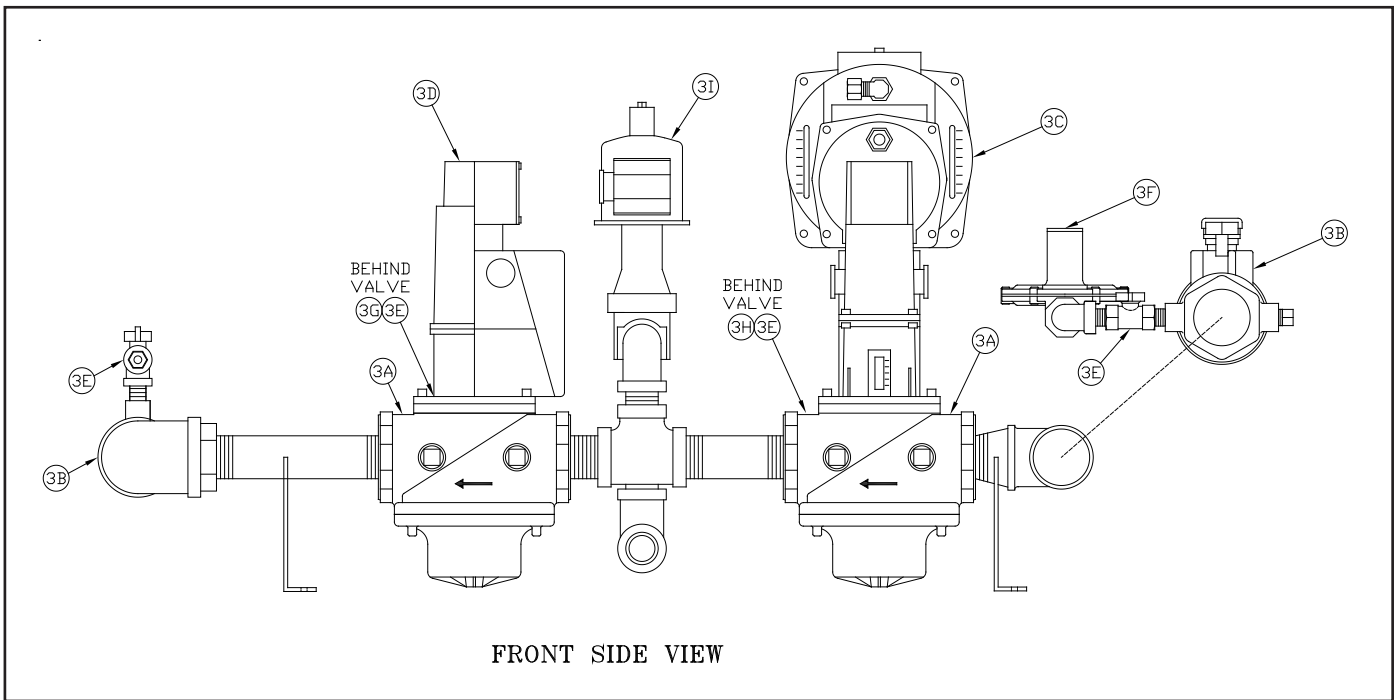
**Figure 20: Burner Assembly**

BURNER ASSEMBLY									
Key No.	Description	(Quantity) Part Number							
		EVA-500	EVA-750	EVA-1000	EVA-1500	EVA-2000	EVA-2000S	EVA-2500	EVA-3000
<b>2. BURNER/FAN ASSEMBLIES</b>									
2A	Fan (120V / 1 ph) On/Off Models	(1) 811560022		(1) 81156001			(1) 81156018		N/A
	Fan (3 phase)	113568-01		113568-02					113568-03
2B	Air Filter	(1) 81156009		(1) 81156011			(1) 81156012		(1) 81156101
2C	Pilot Assembly - NG - OR - Pilot Assembly - LP	See Figure 25 (Pilot Assembly)							
	Mixer Assembly - NG	(1) 602561031	(1) 60256209	(1) 60256210	(1) 60256211	(1) 60256212			(1) 62156300
2D	Mixer Assembly - LP	(1) 602561061	(1) 60256213	(1) 60256214	(1) 60256215	(1) 60256216			(1) 62156300
2E	Burner Element	113485-01	113485-02	113485-03	113485-04	113485-05	113485-06	113485-07	113485-08
2F	Air Orifice Gasket	(2) 82056061		(2) 82056063					(2) 82056666
2G	Air Orifice (Modulation)	(1) 802561041	(1) 80256234	(1) 80256235	(1) 80256236	(1) 80256237	(1) 80256237	(1) 82156307	N/A
2H	Pilot Gasket	(1) 82056068							
2I	Gas Mixing Orifice	(1) 80256134							N/A
2J	Burner Gasket	(1) 82056071		(1) 82056041				(1) 82056501	
2K	Burner Mounting Flange Gasket	(1) 82056069		(1) 82056065				(1) 82056665	
2L	Burner/Gas Mixer Thermal Fuse Assembly		(1) 113282-02						N/A
2M	Vestibule Fuse Assembly	(1) 113282-01							
2N	Burner Protective Cover for Service	113484-01	113484-02	113484-03	113484-04	113484-05	113484-06	113484-07	113484-08
NA	Silicone Tubing	113569-01 (includes 3 ft. of tubing)							
NA	Aluminum Tubing	3/8": 113570-01 (includes 3 ft.) 1/4": 113570-02 (includes 5 ft.)							

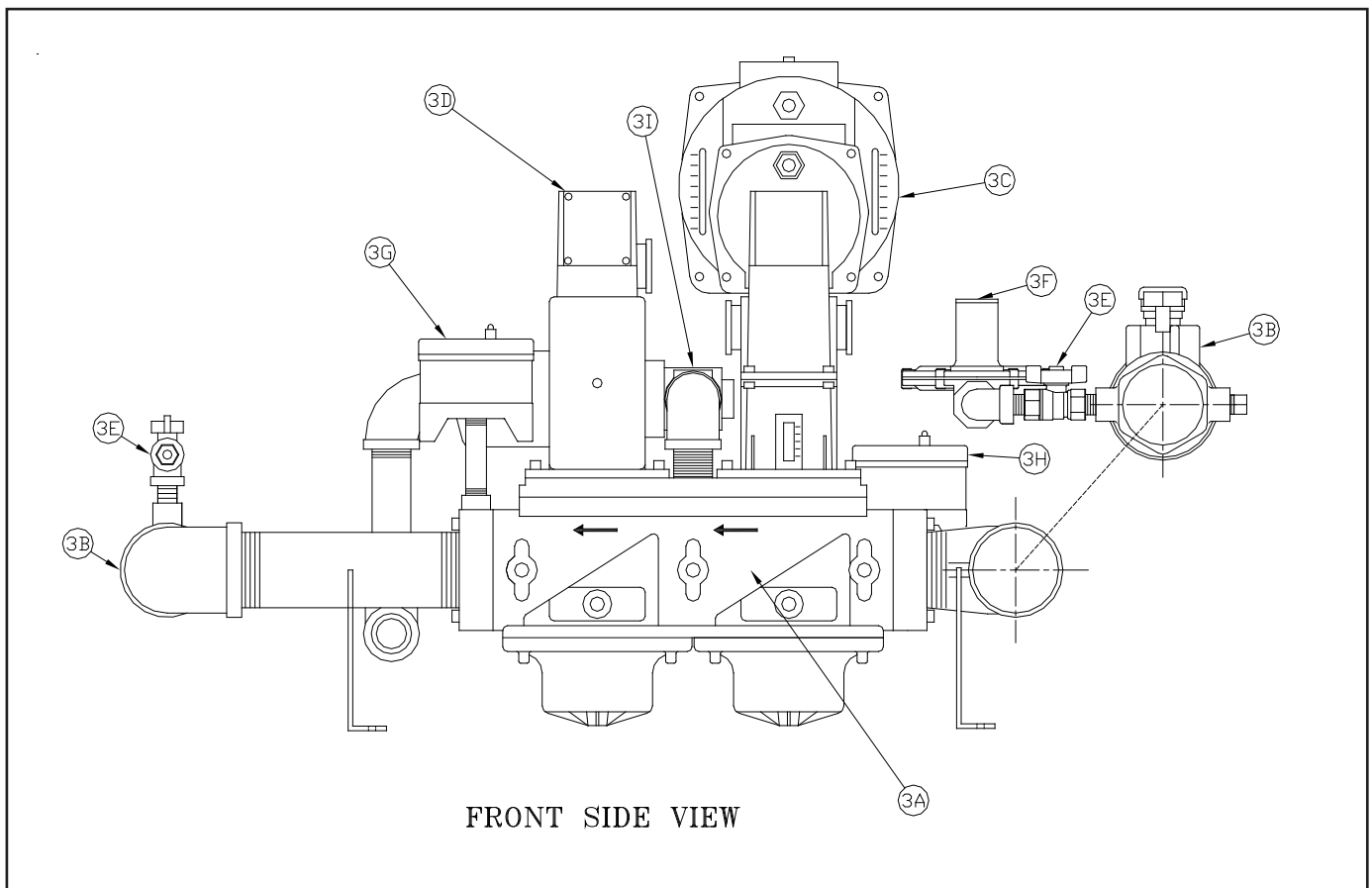


**Figure 21: UL/FM/CSD-1 Main Gas Train Assembly**

UL/FM/CSD-1 GAS TRAIN - MAIN AND PILOT									
Key No.	Description	(Quantity) Part Number							
		EVS-500	EVS-750	EVS-1000	EVS-1500	EVS-2000	EVS-2000S	EVS-2500	EVS-3000
3. Main and Pilot Gas Train (UL/FM/CSD-1)									
3A	Main Gas Valve Body 1" NPT	(1) 816634041		--	--	--	--	--	--
	Main Gas Valve Body, 1-1/2" NPT	--	--	(1) 81663404				--	--
	Main Gas Valve Body, 2" NPT	--	--	--	--	--	--	(1) 816634043	
3B	Manual Gas Valve with Pilot Tapping, 1" NPT	(1) 806603055		--	--	--	--	--	--
	Manual Gas Valve with Pilot Tapping, 1-1/2" NPT	(1) 806603053		(2) 806603053				--	--
	Manual Gas Valve with Pilot Tapping, 2" NPT	--	--	--	--	--	--	(2) 806604691	
3C	Air/Gas Ratio Controller, Siemens SKP75	(1) 81663408							
3D	Solenoid Valve, V4295A1031, 1" NPT	(1) 81660207		--	--	--	--	--	--
	Solenoid Valve, V4295A1056, 1-1/2"	--	--	(1) 81660205				--	--
	Solenoid Valve, V4295A1064, 2"	--	--	--	--	--	--	(1) 816602051	
3E	Manual Gas Cock 1/4"	(3) 81660848							
3F	Pilot Gas Regulator	(1) 822702							
3G	High Gas Pressure Switch	(1) 112067-01							
3H	Low Gas Pressure Switch	(1) 112067-02							



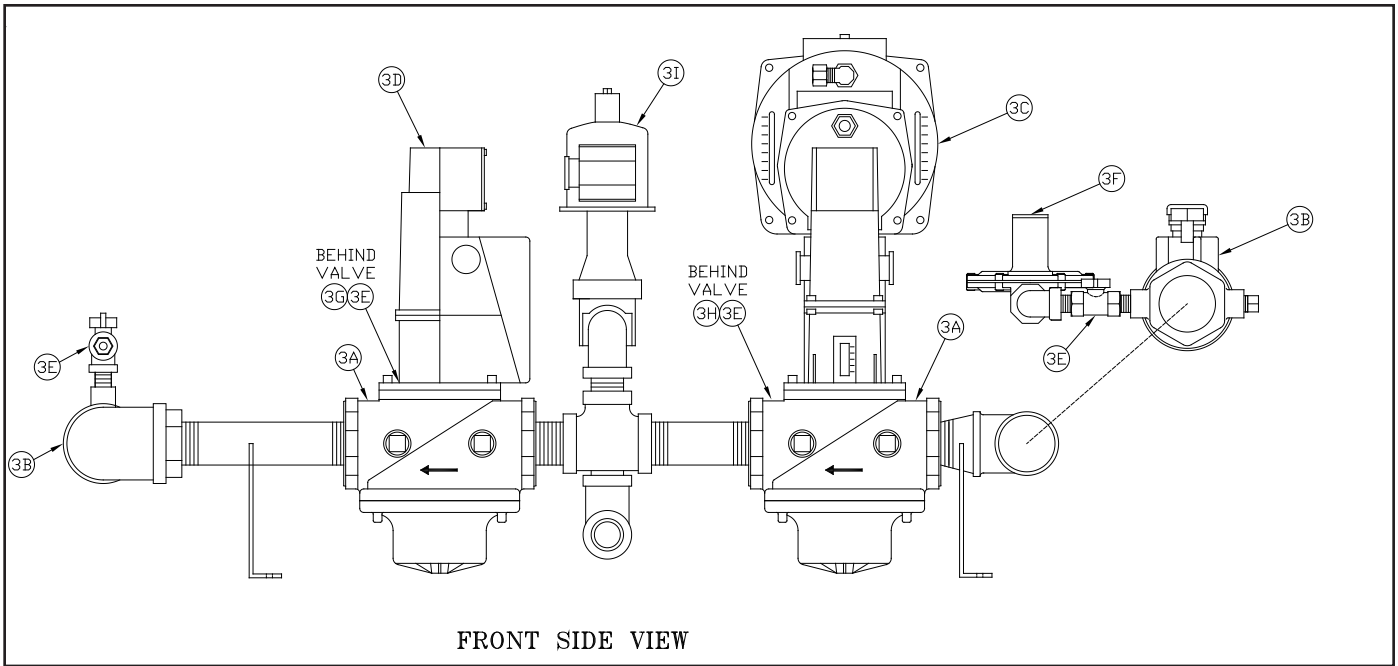
**Figure 22a: DB&B Gas Train (500-750)**



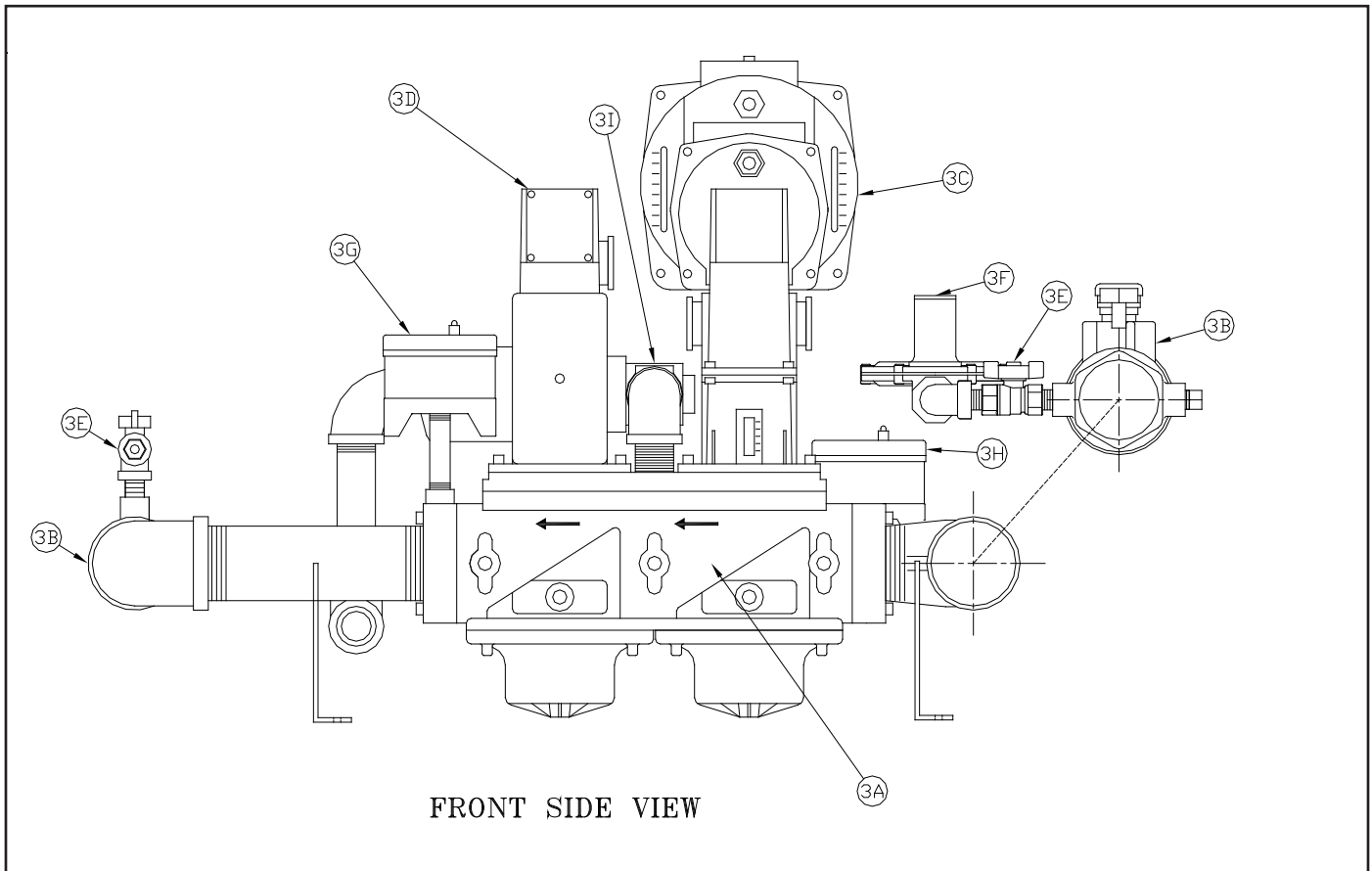
**Figure 22b: DB&B Gas Train (1000-2000)**

**DB&B – MAIN AND PILOT**

Key No.	Description	(Quantity) Part Number				
		EVS-500	EVS-750	EVS-1000	EVS-1500	EVS-2000
		<b>3. MAIN AND PILOT GAS TRAIN</b>				
3A	Main Gas Valve Body 1" NPT	(1) 816634041	—	—	—	
	Main Gas Valve Body, DBL, 1-1/2" NPT	—	(1) 81663404			
3B	Manual Gas Valve with Pilot Tapping, 1" NPT	(1) 806603055	—	—	—	
	Manual Gas Valve with Pilot Tapping, 1-1/2" NPT	(1) 806603053	(2) 806603053			
3C	DB&B Actuator/Regulator Ratio Valve, Siemens SKP75 (max 5 PSI)	(1) 81663408				
3D	DB&B Solenoid Valve	(1) 81660207	(1) 81660205			
3E	Manual Gas Cock, 1/4"	(3) 81660848				
3F	Pilot Gas Regulator	(1) 822702				
3G	High Gas Pressure Switch	(1) 112067-01				
3H	Low Gas Pressure Switch	(1) 112067-02				
3I	Normally Open Vent Valve	(1) 81660748				



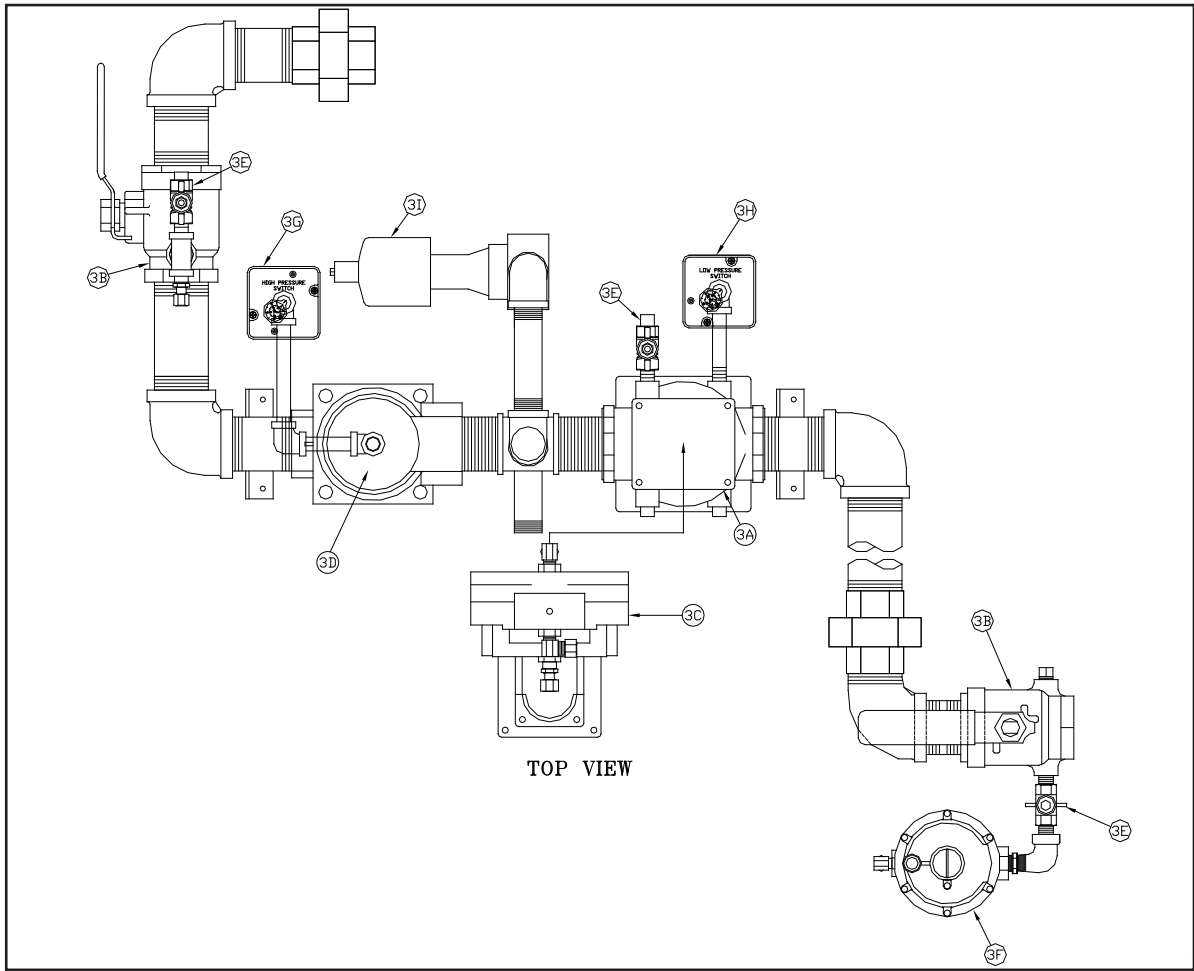
**Figure 22c: DB&B w/POC Gas Train (500-750)**



**Figure 22d: DB&B w/POC Gas Train (1000-2000)**

<b>DB&amp;B W/POC - MAIN AND PILOT</b>			
Key No.	Description	(Quantity) Part Number	
		EVS-500	EVS-750
<b>3. Main and Pilot Gas Train</b>			
3A	Main Gas Valve Body 1" NPT	(2) 816634041	
3B	Manual Gas Valve with Pilot Tapping, 1" NPT	(2) 806603055	
3C	Actuator/Regulator Ratio Valve, Siemens SKP75, (max 5psi), DB&B w/POC	(1) 81663409	
3D	Actuator, Siemens SKP15, DB&B w/POC	(1) 81663407	
3E	Manual Gas Cock, 1/4"	(3) 81660848	
3F	Pilot Gas Regulator	(1) 822702	
3G	High Gas Pressure Switch	(1) 112067-01	
3H	Low Gas Pressure Switch	(1) 112067-02	
3I	Normally Open Vent Valve	(1) 81660262	

<b>DB&amp;B W/POC – MAIN AND PILOT</b>				
Key No.	Description			
		EVS-1000	EVS-1500	EVS-2000
<b>3. MAIN AND PILOT GAS TRAIN</b>				
3A	Main Gas Valve Body, DBL, 1-1/2" NPT	(1) 81663404		
3B	Manual Gas Valve with Pilot Tapping, 1-1/2" NPT	(2) 806603053		
3C	DB&B w/POC Actuator/Regulator Ratio Valve, Siemens SKP75 (max 5 PSI)	(1) 81663409		
3D	DB&B w/POC Actuator, Siemens SKP15	(1) 81663407		
3E	Manual Gas Cock, 1/4"	(3) 81660848		
3F	Pilot Gas Regulator	(1) 822702		
3G	High Gas Pressure Switch	(1) 112067-01		
3H	Low Gas Pressure Switch	(1) 112067-02		
3I	Normally Open Vent Valve	(1) 81660748		



**Figure 22e: DB&B Gas Train (2000S-3000)**

<b>EVS Modulation DB&amp;B</b>			
Key No.	Description	(Quantity) Part Number	
		EVS-2000S	EVS-2500 to 3000
3A	Main Valve Body	(1) 81663404	(1) 816634043
3B	Manual Gas Valve	(2) 806603053	(2) 806604691
3C	Ratio Valve	(1) 81663408	
3D	Actuator	(1) 81660205	(1) 8016602051
3E	Gas Cock	(3) 81660848	
3F	Pilot Regulator	(1) 822702	
3G	High Pres. Switch	(1) 112067-01	
3H	Low Pres. Switch	(1) 112067-02	
3I	Vent Valve (N.O.)	(1) 81660748	(1) 816607501

**Blank Page**

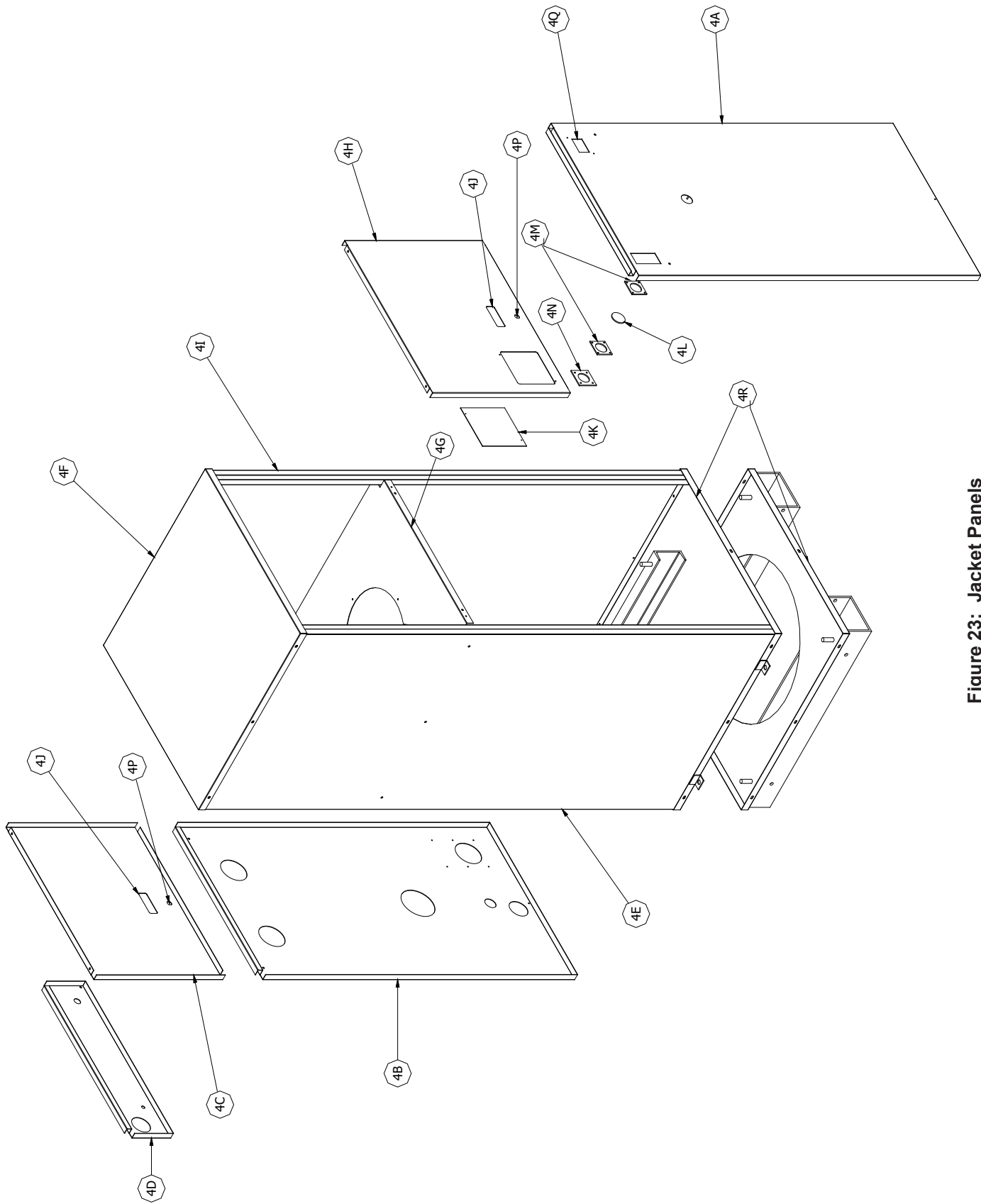


Figure 23: Jacket Panels

<b>JACKET (indoor models)</b>									
Key No.	Description	EVA-500	EVA-750	EVA-1000	EVA-1500	EVA-2000	EVA-2000S	EVA-2500	EVA-3000
		4. Jacket Assembly							
4A	Jacket Lower Front Panel (Modulation)	(1) 60456316	(1) 60456317 60456318	(1) 60456318 60456319	(1) 60456319 60456320	(1) 60456320	(1) 6045612030	(1) 6045602530	(1) 6045603030
4B	Jacket Lower Rear Panel	(1) 604563041	(1) 604563051 604563061	(1) 604563061 604563071	(1) 604563071 604563081	(1) 604563081	(1) 6045612040	(1) 6045602540	(1) 6045603040
4C	Jacket Upper Rear Panel		(1) 113572-01					(1) 113572-02	
4D	Jacket Center Rear Panel		(1) 704562501					(1) 704563003	
4E	Jacket Panel Left Side	(1) 604563281	(1) 604563291 604563301	(1) 604563301 604563311	(1) 604563311 604563321	(1) 604563321	(1) 6045612010	(1) 6045602510	(1) 6045603010
4F	Jacket Top Panel		(1) 704562541					(1) 704563000	
4G	Jacket Vestibule Panel	(1) 604563011	(1) 604563021					(1) 604563000	
4H	Jacket Upper Front Panel		(1) 113573-03					(1) 113573-04	
4I	Jacket Panel Right Side	(1) 604563221	(1) 604563231 604563241	(1) 604563241 604563251	(1) 604563251 604563261	(1) 604563261	(1) 6045612020	(1) 6045602520	(1) 6045603020
4J	Handle		(2) 8056256						
4K	View Port Cover for Flame Safeguard		(1) 81356007						
4L	Observation Port Lens		(1) 8026082						
4M	Observation Port Gasket		(2) 8206039						
4N	Observation Port Lens Retainer		(1) 7186019						
4P	Latch		(2) 80861722						
4Q	Power Switch w/Filter Light		(1) 8136363						
4R	Base		(1) 61556024					(1) 61856501	
4S	Jacket Gasket (Sponge Tape)		9056086 (quantity based on panel)						

<b>JACKET (outdoor models)</b>					
Key No.	Description				
		EVO-750	EVO-1000	EVO-1500	EVO-2000
4A	Jacket Lower Front Panel (Modulation)	(1) 60456311	(1) 60456312	(1) 60456313	(1) 60456314
4B	Jacket Lower Rear Panel	(1) 60456305	(1) 60456306	(1) 60456307	(1) 60456308
4C	Jacket Upper Rear Panel	(1) 70456251			
4D	Jacket Center Rear Panel	(1) 70456250			
4E	Jacket Panel Left Side	(1) 60456329	(1) 60456330	(1) 60456331	(1) 60456332
4F	Jacket Top Panel	(1) 70456254			
4G	Jacket Vestibule Panel	(1) 60456302			
4H	Jacket Upper Front Panel	(1) 70456252			
4I	Jacket Panel Right Side	(1) 60456323	(1) 60456324	(1) 60456325	(1) 60456326
4J	Handle	(2) 8056256			
4K	View Port Cover for Flame Safeguard	(1) 81356007			
4L	Observation Port Tens	(1) 8026082			
4M	Observation Port Gasket	(2) 8206039			
4N	Observation Port Lens Retainer	(1) 7186019			
4P	Latch	(2) 80861719			
4Q	Power Switch w/Filter Light	(1) 8136496			
4R	Base	(1) 6155604			
4S	Outdoor Vent Terminal (Not Shown)	(1) 102434-02	(1) 102434-04		

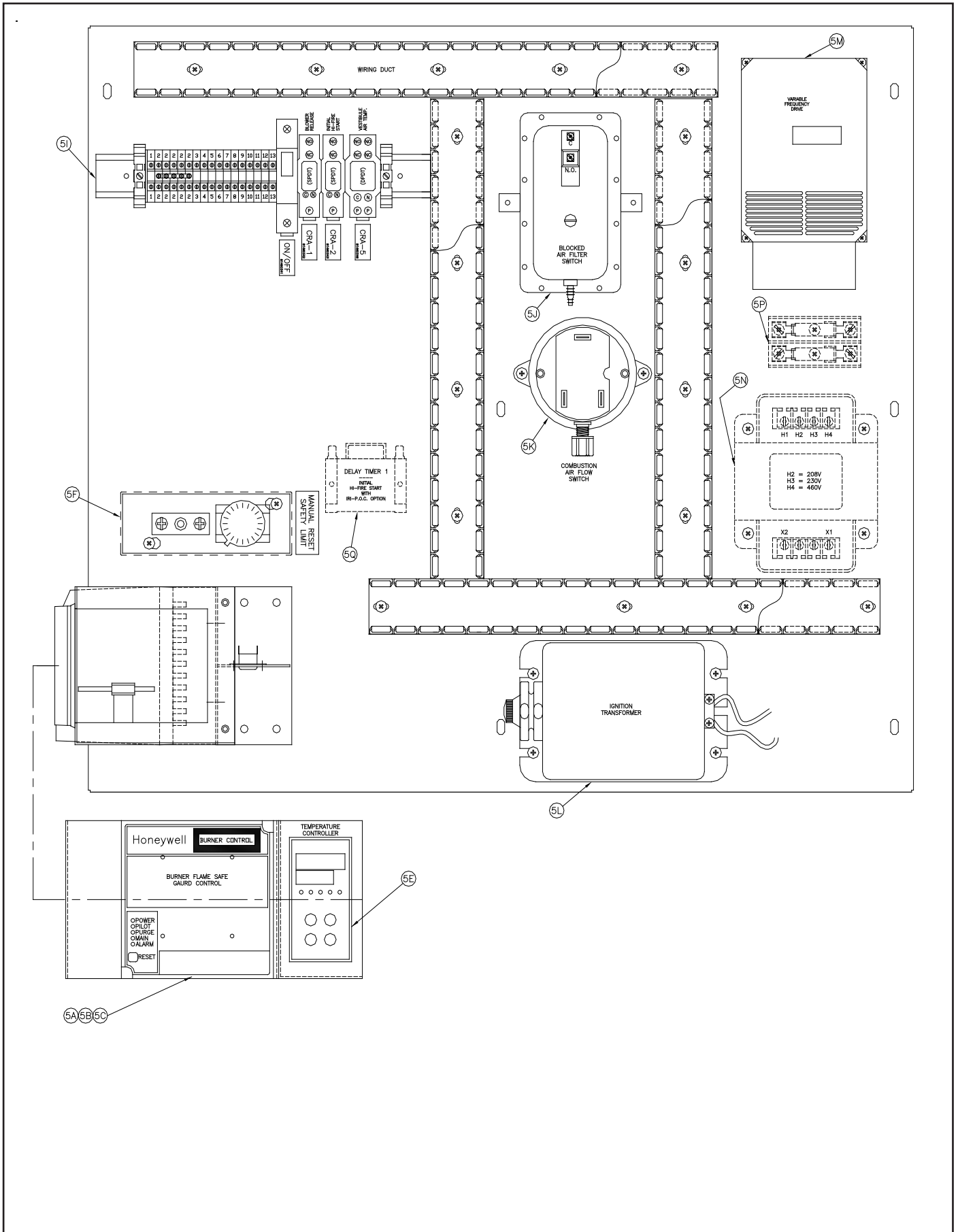


Figure 24: Control Panel Assembly

CONTROLS (Modulation)									
Key No.	Description	(Quantity) Part Number							
		EVA-500	EVA-750	EVA-1000	EVA-1500	EVA-2000	EVA-2000S	EVA-2500	EVA-3000
5. Controls and Components									
5A	RM7896D2027 Flame Safeguard Control for UL/FM/CSD-1/DB&B	(1) 111438-01							
	RM7840L-1075 Flame Safeguard Control for DB&B w/POC	(1) 111438-03							
	Display and Modbus Module for 5A (optional - not shown)	(1) 103003-01							
5B	Amplifier Card (not shown) R7849A1023	(1) 80160243							
5C	Purge Card, 30 seconds (not shown) ST7800A1039, UL/FM/CSD-1/DB&B	(1) 8136362							
	Purge Card, 90 seconds (not shown) ST7800A1062, UL/FM/CSD-1/DB&B	(1) 81363622							
	Purge Card, 2 sec low fire start (not shown) ST7800A1005, DB&B w/ POC/LFP	(1) 81363621							
5D	Power Switch with Filter Light (not shown)	(1) 8136363							
	Power Switch with Filter Light, EVO (not shown)	(1) 8136496							
5E	Operating Limit, Digital Modbus, RWF55	(1) 106203-01							
5F	High Limit L4008E1305 (Manual Reset - max 240F)	(1) 80160667							
	High Limit L4008E1313 (Manual Rest - max 200F) (optional)	(1) 80160660							
5G	Water Flow Switch (not shown)	(1) 105687-01							
5H	Vestibule Fuse Switch (not shown)	(1) 113282-01							
5I	Terminal Block/Circuit Breaker Assembly	(1) 8136498							
5J	Blocked Filter Switch	(1) 80160295							
5K	Combustion Air Flow Switch	(1) 102382-02							
5L	Ignition Transformer	(1) 80160018							
5M	Variable Frequency Drive 115/120 Volt input	(1) 109903-01						N/A	
	Variable Frequency Drive (VFD) 208/230 Volt Single Phase Input	(1) 109903-02							
	Variable Frequency Drive (VFD) 208/230 Volt Three Phase Input	(1) 109903-04							
	Variable Frequency Drive 460 volt 3 Phase Input	(1) 109903-03							
5N	Control Transformer (High Voltage Option)	(1) 80160820							
5P	Fuses and Fuse Block (High Voltage Option)	(2) 8136426 & (2) 8136427							
5Q	Delay Timer (No Timer for EVA500-2000 UL/FM,CSD-1)	(1) 80160675							
5R	Resistor 1k 25watt (LFP option only) (not shown)	(1) 103577-01							

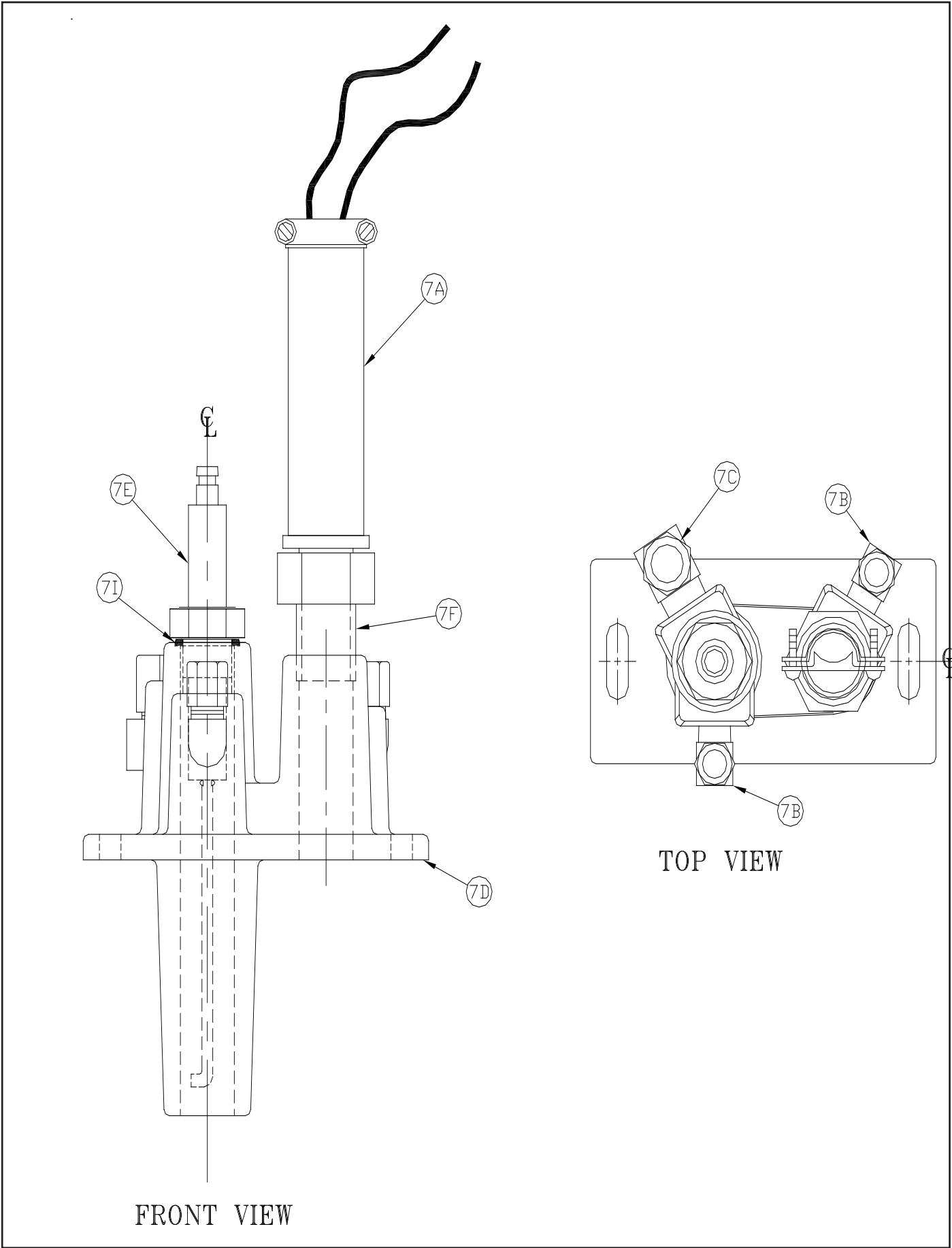


Figure 25: "Bishop" Pilot Assembly

<b>PILOT ASSEMBLY (Bishop Design)</b>		
Key No.	Description	(Quantity) Part Number
		EVS-500-3000 (all sizes)
7. Pilot Assembly, Bishop		
---	Pilot Assembly, Natural Gas, ULX2	(1) 113283-01
---	Pilot Assembly, Propane, ULX2	(1) 113283-02
	Pilot Assembly, Venturi (low gas press.)	(1) 113283-03
7A	Ultraviolet Sensor	(1) 112086-02
7B	Pilot Orifice, Natural Gas	(1) 722606
	Pilot Orifice, Propane	(1) 722605
7C	Pilot Air Orifice	(1) 722607
7D	Cast Iron Body	(1) 82361581
7E	Ignitor Assembly, ULX2	(1) 82356009
7F	Nipple, 1/2 NPT x Close	(1) 806600040
7G	Pilot Ignition Cable (not shown)	(1) 103827-01
7H	Pilot Solenoid Valve V4046C1047	(1) 81660204
7I	O-Ring	(1) 8206054

## XII. Temperature Controller Operation



### A. Description

The microprocessor based temperature controller is utilized for all modulating Thermal Solutions water boilers. The basic function of the controller is to modulate the firing rate of the burner in response to the boiler heat load. The controller monitors the boiler water temperature through the use of a sensor located in the boiler pressure vessel. The controller compares the boiler water temperature to the controller's user defined operating set-point temperature.

An output signal from the microprocessor varies the blower speed through the use of a variable frequency drive (VFD). The gas valve regulates an appropriate amount of gas flow for a given air flow or blower speed. The user may adjust the operating set-point temperature for a given application. In addition, the controller has the ability to change to an alternate set-point through an external signal for low load conditions (i.e. weekend use, night setback). Outdoor reset is another standard feature, allowing the boiler operating temperature to vary based on the outdoor ambient temperature. The typical result is a higher seasonal efficiency.

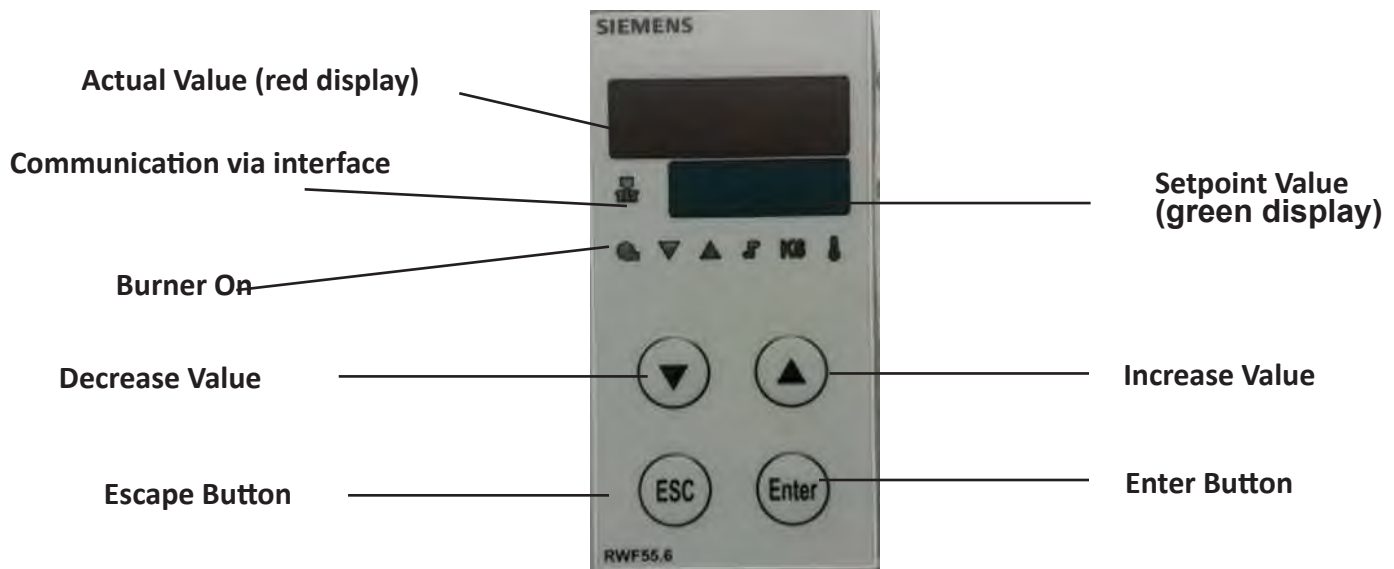
Other features include:

<b>Low Fire Hold</b>	<b>Multiple Analog Inputs</b>
<b>Multiple Set Points</b>	<b>Mod Bus Communications</b>
<b>Digital Inputs</b>	<b>Manual Override</b>
<b>"AUTO TUNE" Optimization</b>	

### B. Set-Up

All of the control parameters have been set at the factory. There are a few parameters called "Process Parameters" that must be defined by a qualified operator. The table below will help serve as a reference and record when making adjustments.

<b>Parameter</b>	<b>Display</b>	<b>Value Range*</b>	<b>Factory Setting</b>	<b>User Setting</b>
<b>Setpoint 1</b>	SP1	145-240	180	
<b>Setpoint 2</b>	SP2	145-240	0	
<b>Digital Setpoint Shift (optional)</b>	dSP	145-240	0	



To alter any of these process parameters follow the following steps:

- To obtain access into the programming mode of the controller, briefly press the button **“Enter”**, so OPr is displayed on the second line in green LEDs.
- Press **“Enter”** again so that "SP1" appears. Press **“Enter”** once more so "SP1" flashes. The previously set operating temperature will be displayed on the first line in red LEDs.
- To increase or decrease the setpoint 1 value (SP1) use the up and down arrow keys respectively. Press **“Enter”** to confirm.
- To set the value for “SP2”, briefly press the "downward" key so "SP2" appears, then follow the same instructions as above.
- To return to the operating mode press **“ESC”**, otherwise the unit will automatically return to the operating mode after 30 seconds of no activity.

To make other adjustments, contact your local representative or consult the factory.

### C. Adjustments

Often during troubleshooting conditions it may become necessary to manually adjust the firing rate. Follow the instructions below to make manual firing rate adjustments.

- Press **“ESC”** button and hold for 5 -10 seconds.
- "Hand" will appear on the lower display, flashing between that and the firing rate value.
- Press up button to raise firing rate. Press down button to lower firing rate.
- 0 = Minimum firing rate and 100 = Maximum firing rate. Press "Enter" to confirm.
- Press **“ESC”** button and hold for 5 –10 seconds to return to automatic firing rate control.
- Automatic mode has been re-activated once the setpoint 1 value is displayed in green LEDs.

### D. Other

#### System Specifications

Input voltage	-----	110-240vac +10-15, 48/63hz
Transducer supply	-----	24VDC, 30ma
Analog Input 1	-----	Pt100,Ni100, Thermocouple (J, K, T or N),4-20ma and Analog 0-10v
Analog Input 2	-----	1k pot,4-20ma, 0-1VDC, 0-10 VDC
Analog Input 3	-----	Pt100,Ni100 Temperature sensors
Output 1 release to modulate-2	-----	4-240VAC 2Amps max
Output 2 and 3 open/close	-----	24-240VAC 2Amps max
Output 4 programmable	-----	24-240VAC 2Amps max
Output 5 analog output	-----	0-10 VDC (500 ohm load min), 0-20 or 4-20ma (500ohm load max)
Mod bus RS485	-----	4800, 9600, 19200, 38400 baud
Data storage	-----	EEPROM
Approvals	-----	UL, CSA, CE

# NOTES

# NOTES

# NON-CONDENSING BOILER START-UP FORM

(REFER TO THE PRODUCT MANUAL FOR QUESTIONS REGARDING THE INSTALLATION AND OPERATION OF THIS PRODUCT)

**JOB NAME:** \_\_\_\_\_ **MODEL #:** \_\_\_\_\_  
**ADDRESS:** \_\_\_\_\_ **SERIAL #:** \_\_\_\_\_  
**CITY:** \_\_\_\_\_ **ST:** \_\_\_\_\_ **ZIP:** \_\_\_\_\_ **DATE:** \_\_\_\_\_

**GAS SUPPLY:**     Natural Gas                      Static Pressure (Unit Off): \_\_\_\_\_ "wc                      Gas Pipe Diameter: \_\_\_\_\_ " (inches)  
                           LP Gas    Dynamic Pressure (100% Fire): \_\_\_\_\_ "wc

Is there an inlet gas lockup regulator on the supply?     Yes     No  
 If **Yes**, is it ten feet upstream from the appliance?     Yes     No, explain: \_\_\_\_\_

OPERATING PARAMETERS:	SETTING	
Pilot Gas Pressure (w.c.i.)		
Manifold Pressure (during "Purge" - at high fire)		
Gas Supply Pressure (at inlet to Evolution gas train – all units on) (w.c.i. or psi)		
	High Fire:	Low Fire:
Manifold Gas Pressure (w.c.i.)		
VFD Freq. (Hz)		
CO (ppm – corrected to 3%O <sub>2</sub> )		
CO <sub>2</sub> (%)		
O <sub>2</sub> (%)		
Excess Air (%)		
Stack Temp (°F)		
Combustion Efficiency (%)		
Gas Pressure Switch Settings (w.c.i.)		
High Temp Aquastat Setting (°F)		

**WATER:**                      Supply Temperature: \_\_\_\_\_ °F                      Return Temperature: \_\_\_\_\_ °F                      Delta T \_\_\_\_\_ °F

**ELECTRICAL:**                      Supply Voltage: \_\_\_\_\_                      Total Amp Draw: \_\_\_\_\_

VENTING & AIR INTAKE:			Vent:			Combustion Air:			
<b>Refer to O&amp;M Manual</b>			Material: _____			Material: _____			
			Diameter: _____ "			Diameter: _____ "			
			<u>Sub-Total</u>				<u>Sub-Total</u>		
90° SR Elbow:	_____ Qty	_____ ft / ea	_____ ft	90° SR Elbow:	_____ Qty	_____ ft / ea	_____ ft		
90° LS Elbow:	_____ Qty	_____ ft / ea	_____ ft	90° LS Elbow:	_____ Qty	_____ ft / ea	_____ ft		
45° Elbow:	_____ Qty	_____ ft / ea	_____ ft	45° Elbow:	_____ Qty	_____ ft / ea	_____ ft		
Horizontal Straight:	_____ Lgth	_____ 1 ft / 1ft	_____ ft	Horizontal Straight:	_____ Lgth	_____ 1 ft / 1ft	_____ ft		
Vertical Straight:	_____ Lgth	_____ 1 ft / 1ft	_____ ft	Vertical Straight:	_____ Lgth	_____ 1 ft / 1ft	_____ ft		
Total Equiv. Length:			_____ ft	Total Equiv. Length:			_____ ft		

\* SR - Short Radius / LS - Long Sweep/Sanitary Elbow

**Notes (Refer to O&M Manual):**  
 1. Make sure total equiv. length does not exceed max equiv. length shown in Manual.  
 2. Vent and combustion air terminals do not count towards total equivalent length.  
 3. Pressure drop for flexible polypropylene liner is 20% greater than for rigid pipe. Multiply measured flexible polypropylene line length by 1.2 to obtain equivalent length.  
 4. Max equivalent length of flexible polypropylene liner is 48 ft.  
 5. All elbows referenced are short radius.

**Vent / Air Termination:**

Vertical Vent w/ Room Air     Vertical Direct Vent  
 Horizontal Vent w/ Room Air     Horizontal Direct Vent  
 Vertical Vent w/ Sidewall Air

**NOTES / COMMENTS:** \_\_\_\_\_  
 \_\_\_\_\_  
 \_\_\_\_\_

<b>START-UP PERFORMED BY:</b>	<b>START-UP APPROVED BY:</b>
COMPANY: _____	COMPANY: _____
ADDRESS: _____	ADDRESS: _____
CITY: _____ ST: _____ ZIP: _____	CITY: _____ ST: _____ ZIP: _____
NAME: _____ PHONE: _____	NAME: _____ PHONE: _____

---

# Warranty

---

## Thermal Solutions

("seller")

## LIMITED WARRANTY

### LIMITED WARRANTY

Subject to the terms and conditions herein and except as provided below with respect to products or parts not manufactured by Thermal Solutions, Seller warrants to the original owner at the original installation site that products manufactured by Seller ("Products") comply, at the time of manufacture, the heat exchanger with recognized hydronics industry regulatory agency standards and requirements then in effect and will be free from defects in materials and workmanship for a period of 5 years from date of shipment (the "Warranty Period"). The burner is also covered under the limited warranty for 10 years from date of shipment (the "Warranty" Period). For products or parts not manufactured by Thermal Solutions, the warranty obligations of Thermal Solutions shall, in all respects, be limited to one year.

### REMEDY

- A. The sole remedy for breach of this warranty is expressly limited to the repair or replacement of any part found to be defective under conditions of normal use within the Warranty Period. Labor for removal and/or installation is not included.
- B. Warranty - The owner must notify the original installer of the Product and Seller (Attention: Thermal Solutions, P.O. Box 3244, Lancaster, PA 17604-3244), in writing, within the Warranty Period, providing a detailed description of all claimed defects. Transportation to a factory or other designated facility for repairs of any products or items alleged defective shall, in all events, be the responsibility and at the cost of the owner.

### EXCLUSIONS

Seller shall have no liability for and this warranty does not cover:

- A. Incidental, special or consequential damages, such as loss of the use of products, facilities or production, inconvenience, loss of time or labor expense involved in repairing or replacing the alleged defective Product.
- B. The performance of any Product under conditions varying materially from those under which such Product is usually tested under industry standards as of the time of shipment.
- C. Any damage to the Product due to abrasion, erosion, corrosion, deterioration, abnormal temperatures or the influence of foreign matter or energy.
- D. The design or operation of owner's plant or equipment or of any facility or system of which any Product may be made a part.
- E. The suitability of any Product for any particular application.

- F. Any failure resulting from misuse, modification not authorized by Seller in writing, improper installation or lack of or improper maintenance.
- G. Equipment furnished by the owner, either mounted or unmounted, or when contracted for by the owner to be installed or handled.
- H. Leakage or other malfunction caused by:
  - 1. Defective installations in general and specifically, any installation which is made:
    - a. in violation of applicable state or local plumbing housing or building codes,
    - b. without a certified ASME, pressure relief valve, or
    - c. contrary to the written instructions furnished with the unit.
  - 2. Adverse local conditions in general and, specifically, sediment or lime precipitation in the tubes and/or headers or corrosive elements in the atmosphere.
  - 3. Misuse in general and, specifically, operation and maintenance contrary to the written instructions furnished with the unit, disconnection, alteration or addition of components or apparatus, not approved by seller, operation with fuels or settings other than those set forth on the rating plate or accidental or exterior damage.
- I. Production of noise, odors, discoloration or rusty water.
- J. Damage to surrounding area or property caused by leakage or malfunction.
- K. Costs associated with the replacement and/or repair of the unit including: any freight, shipping or delivery charges, any removal, installation or reinstallation charges, any material and/or permits required for installation reinstallation or repair, charges to return the boiler and or components.

Seller's liability under this warranty shall not in any case exceed the amount paid for the Product found to be defective.

### THIRD-PARTY WARRANTIES

For goods or components not manufactured by Seller, the warranty obligations of Seller shall, in all respects, conform and be limited to one year from the date of shipment

### SEVERABILITY

To the extent that any provision of this warranty would be void or prohibited under applicable law, such provisions shall be limited in effect to the minimum extent necessary to render the remaining provisions hereof enforceable.

