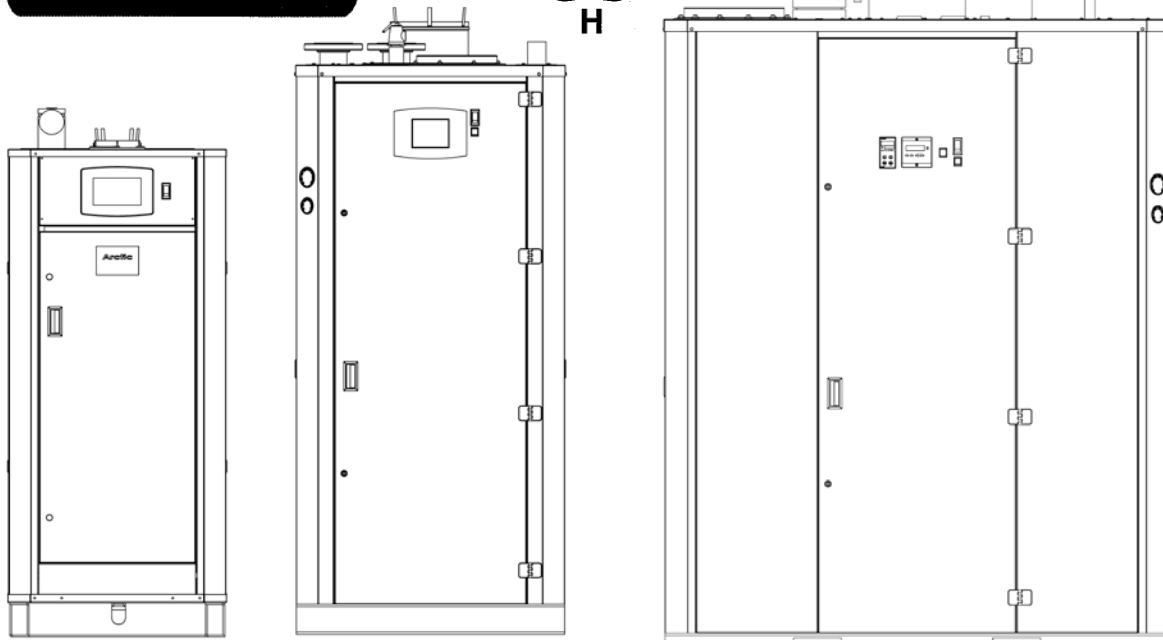
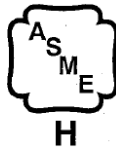


# ARCTIC

High Efficiency, Low Emission  
 CONDENSING BOILER

## INSTALLATION & OPERATION MANUAL



For service and repair to the boiler, call your heating contractor. When seeking information on the boiler from the manufacturer, provide boiler model and serial number as shown on the rating label.

Boiler Model:	Serial Number:
Installation Date:	Type System:
Heating Contractor:	Phone/Email:
Address:	



This manual must only be used by a qualified heating installer/service technician. Read all instructions in this manual before installing. Perform steps in the order given. Failure to comply could result in severe personal injury, death, or substantial property damage.



## Table of Contents

1	Introduction.....	6
1.1	Important Information.....	6
1.2	Disclaimers and Local Codes.....	6
1.3	Test and Inspections.....	7
1.4	Component Description.....	8
2	Pre-Installation.....	10
2.1	Installation Conformance.....	10
2.2	Boiler Foundation.....	10
2.3	Clearances and Serviceability.....	10
3	Installation.....	12
3.1	Receiving The Boiler.....	12
3.2	Boiler Connections.....	12
3.2.1	Flow Connection.....	12
3.2.2	Safety Relief Valves.....	12
3.2.3	Minimum Relief Valve Settings.....	12
3.2.4	Expansion Tank Connections.....	12
3.2.5	Drain Connection.....	12
3.2.6	Condensate Drain Connection.....	13
3.2.6.1	ARC1000 Condensate Drain Trap.....	13
3.2.6.2	ARC1500 – 6000 Condensate Drain Trap.....	14
3.2.7	Gas Supply Connection.....	14
3.2.7.1	Drip Leg.....	14
3.2.7.2	Gas Piping Leak Test.....	14
3.2.7.3	Venting of Gas Train Components.....	14
3.3	Combustion Air Supply System.....	15
3.3.1	Combustion Air Openings:.....	15
3.3.1.1	Two Permanent Opening Method.....	15
3.3.1.2	One Permanent Opening Method.....	15
3.3.1.3	Mechanical Air Supply Systems.....	16
3.3.2	Louvers, Grilles, and Screens.....	16
3.3.2.1	Louvers and Grilles:.....	16
3.3.2.2	Screens.....	16
3.3.2.3	Motorized Louvers:.....	16
3.3.2.4	Combustion Air Ducts.....	16
3.3.3	Ducted Combustion Air.....	17
3.4	Venting Requirements.....	17
3.4.1	Category II Venting.....	19
3.4.2	Massachusetts.....	20
3.4.3	Combustion Air and Venting Requirements for Canada.....	21
3.4.3.1	Air Supply Requirements per CAN/CSA-B149.1-05 for Appliances having an input exceeding 400 MBH.....	22
3.4.3.2	Combustion Air Supply Dampers, Louvers, and Grilles.....	22
3.4.3.3	Mechanical Combustion Air Supply.....	22
3.4.3.4	Appliance Venting per CAN/CSA-B149.1-05.....	22
3.5	Requirements.....	23
3.5.1	Electrical.....	23
3.5.2	Gas Supply Requirements.....	24
3.5.3	Sound Pressure Levels.....	24

3.5.4	Pump and Piping Requirements.....	24
3.5.4.1	Water Flow Rates (Variable Primary Pumping Systems).....	25
3.5.4.2	Water Flow Rates (Primary / Secondary Systems).....	25
3.5.4.3	Water Flow Rates (Constant Volume Primary Pumping Systems).....	27
3.5.4.4	Water Flow Rates for Glycol .....	27
3.6	Before Placing Boiler In Operation.....	27
3.6.1	Pre-Boil Out Flushing Of System .....	27
3.6.2	Boil Out Procedure.....	28
3.6.3	Replacement Boiler Installations.....	28
3.7	Draining and refilling the boiler & system .....	28
3.7.1	Filling The System .....	29
3.7.2	Hydrostatic Test Of Boilers And System .....	29
3.8	Boiler Water Treatment.....	29
3.8.1	Purpose of water treatment.....	29
3.8.2	Objectives.....	29
3.8.3	Water softener .....	29
3.8.4	Continuous Monitoring.....	29
4	SYSTEM START-UP .....	31
4.1	Concert Boiler Control Display Navigation – This Section applies ONLY to the ARC1000 through ARC3000 .....	31
4.2	System Check:.....	31
4.3	Power the Boiler: .....	31
4.4	Power the Circulators:.....	31
4.5	Pressurize the Fuel System: .....	31
4.6	Boiler Commissioning: This Section applies ONLY to the ARC1000 through ARC3000 .....	32
4.7	Finish Commissioning the Boiler: This Section applies ONLY to the ARC1000 - ARC3000..	34
4.8	Re-Starting After Prolonged Shutdown.....	34
4.9	Testing of Controls and Safety Devices.....	35
4.10	Ignition Failure .....	36
5	Service, Maintenance, and Inspection.....	37
5.1	General Maintenance: .....	37
5.1.1	DAILY:.....	38
5.1.2	WEEKLY: .....	38
5.1.3	MONTHLY:.....	38
5.1.4	ANNUALLY:.....	38
5.2	Ignition Assembly Cleaning.....	38
5.3	Burner Assembly Cleaning.....	39
5.4	Heat Exchanger Cleaning.....	39
5.5	Tube Replacement Procedure .....	40
5.6	Safety and Operating Controls .....	45
5.7	Troubleshooting.....	46
Appendix A	Sizing Gas Piping .....	48
Appendix B	Vent and Combustion Air Pressure Drop Data.....	50
Appendix C	Installation & Startup Report.....	52
Appendix D	Venting Diagrams .....	53
Appendix D.1	Typical Horizontal Vent Piping.....	53
Appendix D.2	Typical Vertical Pressurized Venting.....	54
Appendix E	Combustion Air Diagrams .....	55
Appendix E.1	Typical Horizontal Air Intake Piping .....	55
Appendix E.2	Typical Vertical Air Intake Piping.....	56

**Appendix F Boiler Piping Diagrams – Typical Layout for all Boiler Models (Boilers may look different than pictured) ..... 57**

- Appendix F.1 Single Boiler, Primary / Secondary ..... 57
- Appendix F.2 Multiple Boilers, Primary Reverse-Return Piping..... 58
- Appendix F.3 Multiple Boilers, Primary / Secondary Reverse Return Piping ..... 59
- Appendix F.4 Multiple Boilers, Primary / Secondary Piping ..... 60
- Appendix F.5 Multiple Boilers, Primary / Secondary Piping, Heating with Domestic Hot Water ... 61
- Appendix F.6 Multiple Boilers, Primary / Secondary Piping, Heating with Domestic Hot Water (continued)..... 62

Appendix G Water Flow Pressure Drops ..... 63

Appendix H Wiring Diagrams..... 65

- Appendix H.1 ARC1000 Wiring Diagram ..... 65
- Appendix H.2 ARC1500 To ARC3000 115 VAC Single Phase Wiring Diagram..... 67
- Appendix H.3 ARC1500 To ARC3000 208 – 230 VAC Single Phase Wiring Diagram ..... 69
- Appendix H.4 ARC2000 To ARC3000 208-460 VAC Three Phase Wiring Diagram ..... 71
- Appendix H.5 ARC3500 To ARC6000 208-460 VAC Three Phase Wiring Diagram ..... 73

### Tables

- Table 1 Water Flow Switch Settings ..... 8
- Table 2: Clearances and Serviceability ..... 11
- Table 3: Typical Condensate Flow Rate ..... 13
- Table 4: Combustion Air and Flue Gas Requirements ..... 20
- Table 5: Electrical Requirements ..... 23
- Table 6: Gas Supply Requirements ..... 24
- Table 7 Sound Pressure Levels ..... 24
- Table 8 Minimum Water Flow Rates for Variable Primary Pumping..... 25
- Table 9 Maximum Water Flow Rates for Variable Primary Pumping..... 25
- Table 10 Water Flow Rates for Primary / Secondary Pumping 20F  $\Delta T$  ..... 26
- Table 11 Water Flow Rates for Primary / Secondary Pumping 40F  $\Delta T$  ..... 26
- Table 12: Water Flow Rates for Constant Volume Primary Pumping..... 27
- Table 13 GPM Increase for Glycol Systems..... 27
- Table 14: Chemical Agents and Effects..... 30
- Table 15 Recommended Feed Water Limits ..... 30
- Table 16: Safety Device Test..... 35
- Table 17: Safety and Operating Controls ..... 45
- Table 18: General Troubleshooting ..... 46
- Table 19: Maximum Gas Capacity Of Schedule 40 Pipe ..... 48
- Table 20: Equivalent Lengths Of Standard Pipe Fittings And Valves..... 49
- Table 21: Specific Gravity Correction Factors ..... 49

## Figures

Figure 1: ARC1000 External Boiler Connections and Components .....	9
Figure 2: ARC1500 - 3000 External Boiler Connections and Components .....	9
Figure 3: ARC3500 - 6000 External Boiler Connections and Components .....	9
Figure 4: Clearances and Serviceability .....	11
Figure 5: ARC 1000 Condensate Drain Trap .....	13
Figure 6: ARC1500 - 6000 Condensate Drain Trap .....	14
Figure 7: High Fire Adjustment on the Main Gas Valve Regulator.....	33
Figure 8: Ignition Assembly .....	39
Figure 9: Panel Removal in Preparation for Tube Inspection - ARC1000 .....	41
Figure 10: Panel Removal in Preparation for Tube Inspection - ARC1500-ARC3000 .....	41
Figure 11: Panel Removal in Preparation for Tube Inspection - ARC3500-ARC6000.....	42
Figure 12: Tube Puller Insertion.....	43

## 1 Introduction

### 1.1 Important Information

The following terms are used throughout this manual to bring attention to the presence of hazards of various risk levels, or to important information concerning product life. It is critical that all personnel read and follow all the information provided in the boxes marked DANGER, WARNING, CAUTION, and NOTICE.

#### DANGER

Indicates an imminently hazardous situation, which, if not avoided, will result in death, serious injury or substantial property damage.

#### WARNING

Indicates a potentially hazardous situation, which, if not avoided, could result in death, serious injury or substantial property damage.

#### CAUTION

Indicates a potentially hazardous situation, which, if not avoided, may result in moderate or minor injury or property damage.

#### NOTICE

Indicates specific instructions on installation, operation, or maintenance, which are important but not related to personal injury hazards.

### 1.2 Disclaimers and Local Codes

Installation must conform to the requirements of the authority having jurisdiction. In the absence of such requirements, installation must conform to the *National Fuel Gas Code, NFPA 54/ANSI Z223.1*, and/ or *CAN/CGA B149 Installation Codes*. Where required by the authority having jurisdiction, the installation must conform to the *Standard for Controls and Safety Devices for Automatically Fired Boilers, ANSI/ ASME CSD-1*.

Installation, start-up, and maintenance of this equipment can be hazardous and requires trained, qualified installers and service personnel. Do not install, operate, service or repair any components of this equipment unless you are qualified and fully understand all requirements and procedures. Trained personnel refer to those who have completed Thermal Solutions Service School training specific to this product.

The boiler heat exchanger is manufactured and stamped in accordance with ASME Boiler and Pressure Vessel Code, Section IV for a maximum allowable working pressure and operating temperature of 160 psig (1103 kPa) and 210 F(99 C) respectively. Aqua-stat is factory set at 200 F (93 C).

#### NOTICE

Post these instructions and maintain in legible condition.

### 1.3 Test and Inspections

---

Upon the completion of boiler installation, final air-fuel adjustments are to be made by factory trained service personnel. The emissions data and the O<sub>2</sub> levels at minimum and maximum input rate can be found on the back side of the front-boiler's door, which can be referenced in the future by the boiler operator(s) when troubleshooting and servicing the boiler. In addition, the following tests and inspections are made on each boiler at the factory to ensure it meets our highest safety and functionality standards.

- ASME hydrostatic test inspection
- Electrical components inspection
- Operating & efficiency test
- Final engineering inspection
- Crating inspection

#### **Danger**

**DO NOT store or use gasoline or other flammable vapors or liquids in the vicinity of this or any other appliance.**

**If you smell gas vapors, DO NOT try to operate any appliance—DO NOT touch any electrical switch or use any phone in the building. Immediately, call the gas supplier from a remotely located phone. Follow the gas supplier's instructions or if the supplier is unavailable, contact the fire department.**

### 1.4 Component Description

1. Touchscreen display. (*Used on ARC1000 – ARC3000*) The display provides easy access for viewing and adjusting boiler operational parameters, monitoring historical performance characteristics and annunciating boiler alarm/lockout conditions.
2. Boiler On/Off switch. (*Used on ARC1000 – ARC3000*)
3. Manual gas shutoff valve. The boiler is equipped with two manual gas shut off valves, one located on the incoming gas supply line outside of the boiler, and the other downstream of the main gas valve.
4. Main gas supply connection.
5. Pressure relief valve. The pressure relief protects the heat exchanger from an over-pressure condition.
6. Ducted combustion air flange.
7. Flue gas vent outlet. The boiler comes with a standard AL 29-4C® stainless steel vent connection.
8. Boiler water flow switch. The boiler water flow switch is adjustable within the parameters listed in Table 1.

Settings	Mode Of Operation	
	Switch Closed	Switch Open
Minimum	18	13
Maximum	50	45

**Table 1 Water Flow Switch Settings**

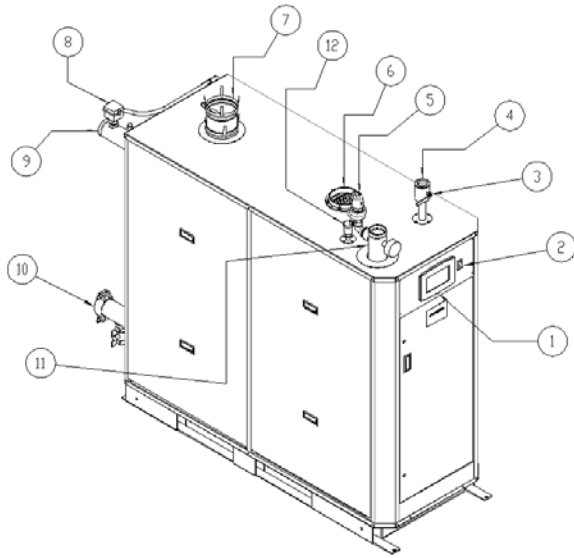
9. Return water connection. A 3” diameter Victaulic grooved connection is provided on the ARC1000. A 3”, 150# class, flange is provided on the ARC1500 – 3000. A 6”, 150# class, flange is provided on the ARC3500-6000.

10. Cleanout and inspection. The ARC1000 has a 3” diameter Victaulic grooved connection is provided for inspecting and cleaning sediment from the heat exchanger. The ARC1500-6000 has a 1” npt pipe for blow down to clean sediment from the heat exchanger and a 3” removable plug for inspecting.
11. Supply water connection. A 3” diameter Victaulic grooved connection is provided on the ARC1000. A 3”, 150# class, flange is provide on the ARC1500 – 3000. A 6”, 150# class, flange is provided on the ARC3500-6000.
12. Air vent. The boiler is provided with an internal dip tube that traps liberated air from the boiler water. The air vent allows the trapped air to escape from the boiler.
13. Boiler reset push button.
14. Boiler water temperature gauge.
15. Boiler water pressure gauge.

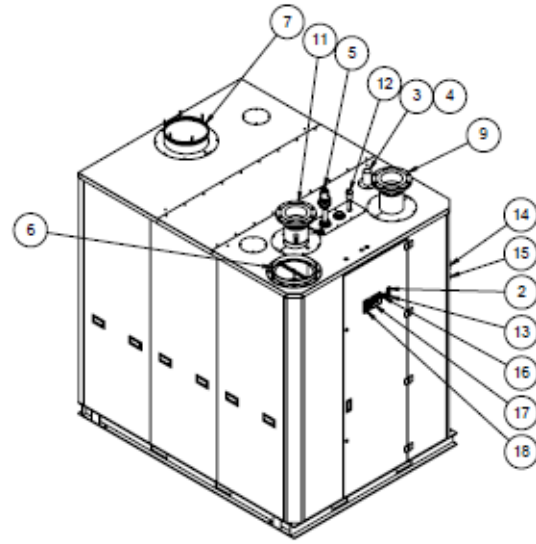
References 16 to 18 are only used on ARC3500 – ARC6000

16. Boiler Hand/Off/Auto
17. Push Button Display. The display provides easy access for viewing and adjusting boiler operational parameters and provides alarm/lockout codes.
18. Temperature Display. Provides for temperature set points and actual temperature.

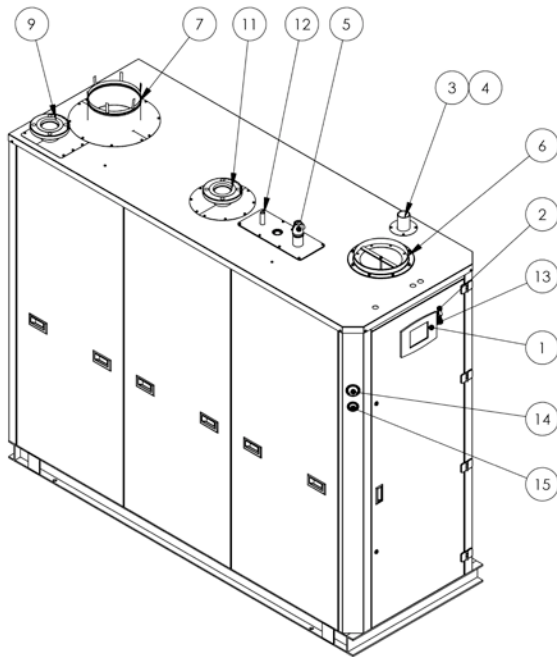




*Figure 1: ARC1000 External Boiler Connections and Components*



*Figure 3: ARC3500-6000 External Boiler Connections and Components*



*Figure 2: ARC1500 - 3000 External Boiler Connections and Components*

## 2 Pre-Installation

The customer should examine the equipment for any damage. It is the responsibility of the installer to ensure all parts supplied with the equipment are fitted in a correct and safe manner.

### WARNING

**This boiler requires regular maintenance and service to operate safely. Follow the instructions contained in this manual.**

### WARNING

**Improper installation, adjustment, alteration, service, or maintenance can cause property damage, personal injury or loss of life. Read and understand the entire manual before attempting installation, start-up operation, or service. Only an experienced, skilled installer or service agency must perform installation and service.**

### WARNING

**This boiler must be properly vented.**

### WARNING

**This boiler needs fresh air for safe operation and must be installed so there are provisions for adequate combustion and ventilation air.**

### 2.1 Installation Conformance

Installation must conform to the requirements of the authority having jurisdiction. In the absence of such requirements, installation must conform to the National Fuel Gas Code, NFPA 54/ANSI Z223.1, and/ or CAN/CGA

B149 Installation Codes. Where required by the authority having jurisdiction, the installation must conform to the Standard for Controls and Safety Devices for Automatically Fired Boilers, ANSI/ ASME CSD-1.

### 2.2 Boiler Foundation

Before uncrating, the boiler location should be prepared. The boiler should set upon a good level concrete floor. If the boiler is not level or the floor is not in good condition, a concrete foundation should be built, the dimensions being larger than the outside dimensions of the boiler base. A 4" high housekeeping pad is suggested.

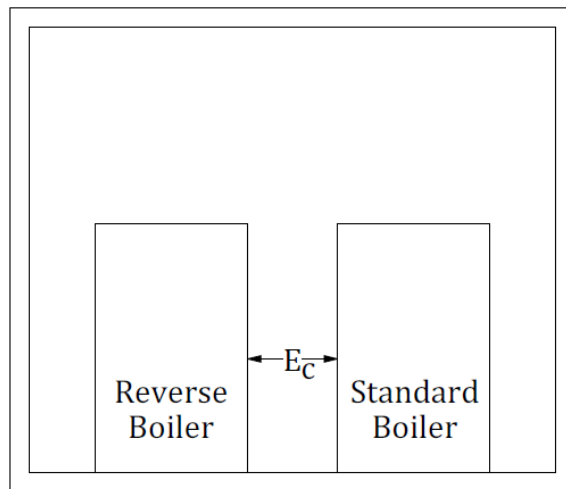
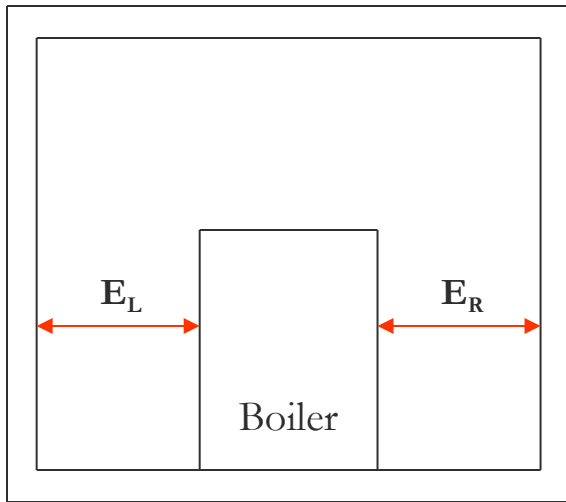
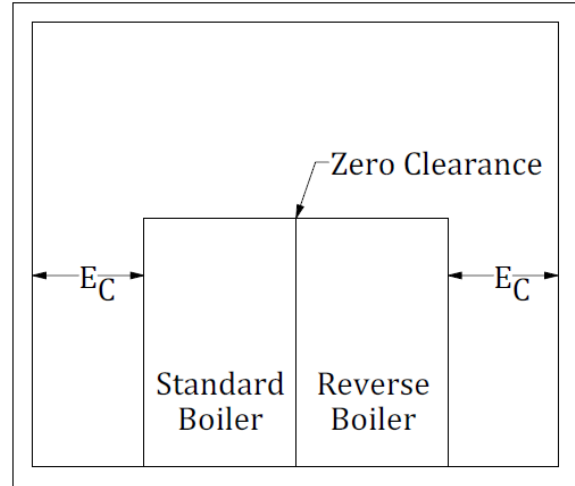
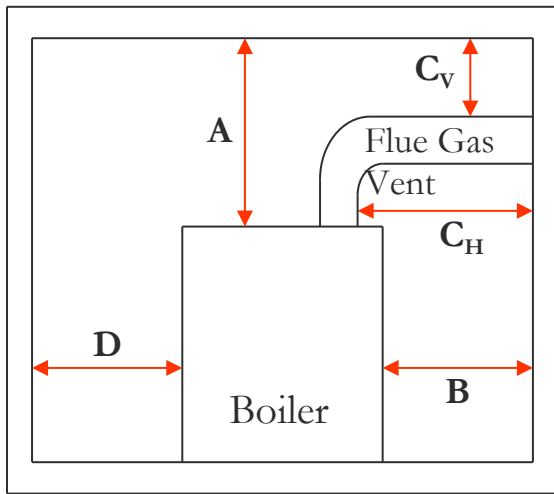
### WARNING

**Do not install boiler on combustible flooring.**

### 2.3 Clearances and Serviceability

See Figure 4 and Table 2 for minimum clearances to walls, ceilings, or obstructions. These clearances are intended as a general recommendation only. Local codes must be applied to specific installations and the minimum clearances established accordingly. Provisions must also be made for service, accessibility and clearance for piping and electrical connections. Do not obstruct combustion air and ventilation openings with piping or any other construction. All boilers must be installed in a space that is large compared to the boiler.

**Figure 4: Clearances and Serviceability**



Dim	Description	1000	1500-3000	3500-6000
A	Clearance Above Top of Boiler	6"	6"	6"
B	Front of Boiler – Burner End	24"	32"	43"
C <sub>H</sub>	From Chimney or Vent Collector measured horizontally	18"	18"	18"
C <sub>V</sub>	From Chimney or Vent Collector measured vertically	18"	18"	18"
D	Rear of Boiler - opposite burner end	6"	6"	6"
E <sub>L</sub>	Left Side - tube access side on standard construction	16"	23"	23"
E <sub>R</sub>	Right Side – tube access side on standard construction (ARC3500-6000)	6"	6"	23"
E <sub>C</sub>	ARC1500 -3000 only	N/A	23"	N/A

**Table 2: Clearances and Serviceability**

## 3 Installation

### 3.1 Receiving The Boiler

The boiler is shipped from the factory with (4) shipping feet/legs bolted to the skids. These are provided to facilitate unloading /moving with a forklift. Lifting points are also provided to enable over-head lifting with spreader bars to prevent damage to the boiler. The shipping feet/legs **MUST BE REMOVED** after the boiler is set in-place on its concrete foundation before any piping/electrical connections are made. It is recommended that the plastic protective cover be left on as long as possible to reduce finish damage from the installation.

### 3.2 Boiler Connections

Do not run any pipes along the tube access panel side of the boiler. Maintain clearances as shown on the dimensional drawing for servicing of the boiler tubes. All piping should be designed and installed to avoid any loadings on the boiler connections or piping.

#### 3.2.1 Flow Connection

The system supply and return flow connections are shown on Figure 1. A gate valve should be installed on the boiler outlet and inlet lines. This allows the boiler to be isolated from the heating system for draining and servicing.

### 3.2.2 Safety Relief Valves

Safety relief valve(s) are shipped loose. Connections are provided in the top of the boiler for the safety relief valve(s). The safety relief valve discharge piping must be the same size as the safety relief valve discharge opening and run to a point of safe discharge. No shutoff valves are to be placed between the relief valve and the appliance or in the discharge piping. Avoid over-tightening as this can distort valve seats. All piping from the safety relief valve(s) must be independently supported with no weight carried by the valve.

#### NOTICE

**If the relief valve discharges periodically, this may be due to thermal expansion in a closed water supply system. Contact the water supplier or local plumbing inspector on how to correct this situation. DO NOT PLUG THIS RELIEF VALVE.**

#### 3.2.3 Minimum Relief Valve Settings

The minimum relief valve setting for standard systems shall be 30 psig. The system shall operate with no less than 26 psig at all times.

For systems designed to operate at delta T's greater than 40°F, the boiler shall be equipped with a minimum relief valve setting of 60 psig. The system shall operate with no less than 50 psig at all times. This will prevent boiler water hammer.

#### 3.2.4 Expansion Tank Connections

Connection(s) to an expansion tank are to be provided by others in the system piping separate from the boiler.

#### 3.2.5 Drain Connection

A drain valve must be installed on the boiler drain connection, the same pipe size as this connection, to allow draining of the boiler.

### 3.2.6 Condensate Drain Connection

A condensate drain trap is shipped with the boiler and is provided with a 1" npt connection to drain the condensed products of combustion from the boiler. Use Pipe with continuous Teflon, high temperature silicone tubing, or other tubing material compatible with flue gas condensate. The condensate temperature should never exceed 212° F and the pH of the condensate should never have a value lower than 3.5. NO VALVE is to be installed in this line from the boiler to point of discharge.

The condensate drain trap should be flushed with water as part of your boiler maintenance schedule to remove any debris that might have accumulated over time.

A common condensate pump/sump may be used. Run separate piping from each condensate drain to the sump. A common drain may be used to discharge condensate from the sump. Consult pump/sump materials of construction. If a common sump is used, individual drain lines should be connected such that one drain cannot back feed into another drain. Use Table 3 for sizing the pump / sump.

Model	Max Condensate Flow (gph)
ARC1000	11.2
ARC1500	16.8
ARC2000	22.4
ARC2500	27.9
ARC3000	33.5
ARC3500	39.1
ARC4000	44.7
ARC4500	50.3
ARC5000	55.8
ARC5500	61.4
ARC6000	67

Consult local authorities regarding disposal of flue gas condensate into public waste water system. Some jurisdictions require that

condensate be buffered before discharge. This buffering is commonly achieved by draining the condensate through a limestone bed. Consult Thermal Solutions or a chemical treatment company for buffering system.

#### CAUTION

**Failure to properly pipe the condensate system will greatly reduce boiler life. Do not install plugs, caps, or valves on condensate piping.**

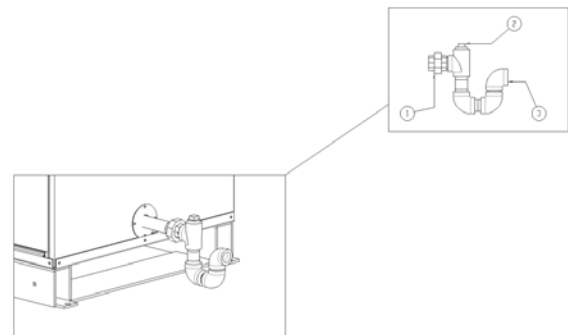
**Do not manifold boiler condensate and vent drains together.**

**Do not crimp condensate lines or reduce drain line inner diameter size.**

#### 3.2.6.1 ARC1000 Condensate Drain Trap

Ensure that the condensate drain trap is filled with water prior to running the boiler to prevent flue gas emission to the boiler room.

It is recommended that the personnel responsible for running and maintaining the boiler periodically check the water level in the condensate drain trap bend, especially, when the boiler is operating in a non-condensing condition for an extended period of time.

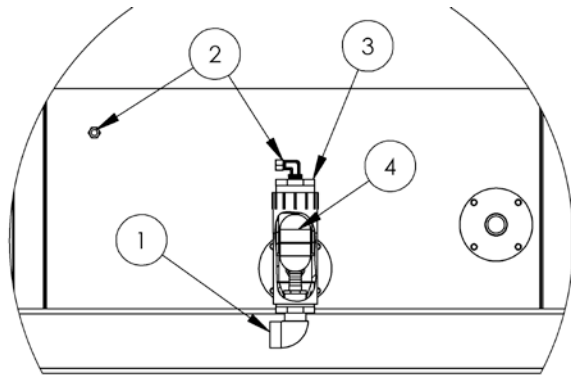


*Figure 5: ARC 1000 Condensate Drain Trap*

1. Union Connection to the boiler condensate drain line
2. Removable cleaning plug

### 3. Condensate drain outlet connection

#### 3.2.6.2 ARC1500 – ARC6000 Condensate Drain Trap



*Figure 6: ARC1500 - 3000 Condensate Drain Trap*

1. 1" npt outlet connection
2. Trap vent connection (tubing not shown for clarity)
3. 2" threaded cleanout
4. Float ball

#### 3.2.7 Gas Supply Connection

The installation must conform completely to the requirements of the authority having jurisdiction, or in the absence of such, requirements shall conform in the U.S. to the current National Fuel Gas Code, ANSI Z223.1-1984, or in Canada to the current Natural gas and propane installation code (CAN/CSA B149.1-05), and applicable regional regulations for the class; which should be followed carefully in all cases. Authorities having jurisdiction should be consulted before installations are made. Refer to paragraph 3.5.2 for gas supply requirements.

##### 3.2.7.1 Drip Leg

A drip leg, or sediment trap, is supplied with the gas train. The gas line must be connected to a supply main at least as large as the gas train connection at the boiler. This connection should be made with a union so that the boiler gas train components and burner may be easily removed for service.

##### 3.2.7.2 Gas Piping Leak Test

After completion of the gas-piping hookup, the installation must be checked for leaks. Leaks shall be checked using a soap and water solution. All joints up to the main motorized gas valve shall be checked. A pressure gauge shall be installed down stream of the main motorized gas valve and up stream of the manual gas shutoff valve in the closed position to ensure the main motorized valves are not leaking by. During commissioning, the remainder of the gas train joints down stream of the main motorized gas valve shall be tested for leaks.

##### 3.2.7.3 Venting of Gas Train Components

The MBC (gas valve) has an internal, factory installed vent limiter re ANSI Z21.18/ CSA 6.3. Venting required unless otherwise accepted by the authority having jurisdiction.

The high and low gas pressure switches incorporate a vent limiter as per UL 353 and limits the escape of gas less than 1.0 CFH of natural gas at 7 PSI if internal switch diaphragm ruptures.

### 3.3 Combustion Air Supply System

For proper combustion it is necessary to provide the boiler room with appropriate openings for fresh air supply. Temporary air intakes such as windows and doors should be avoided since they may be closed. In addition to air needed for combustion, sufficient air must be supplied for ventilation as well as other air consuming equipment that may be present in the boiler room. Often when personnel are working in the boiler room, combustion air openings are closed due to the temperature of the outside air. **THIS MUST BE AVOIDED AT ALL COSTS!** Provisions should be made to heat the outside combustion air, if necessary, for personnel comfort.

Positive means for supplying an ample amount of outside air, allowing for the complete combustion of the gas, must be provided.

Movable combustion air dampers, automatic or manually adjustable, must be electrically interlocked with the boiler to prevent boiler operation if the dampers are closed.

Combustion air openings must never be blocked or obstructed in any manner.

The boiler room must be at a positive or neutral pressure relative to the outdoors. A negative in the boiler room will result in downdraft problems and incomplete combustion due to the lack of air.

#### WARNING!

**Failure to provide an adequate air supply will result in boiler damage and hazardous conditions in the building (fire and asphyxiation hazard as well as equipment damage).**

### 3.3.1 Combustion Air Openings:

The design of combustion air openings **MUST** comply with local and/or State codes or the authority having jurisdiction. As a minimum, combustion air openings to the boiler room shall be provided as follows:

#### NOTICE

**Combustion air provided solely from an indoor source is discouraged. No dimension for a round or rectangular opening shall be less than 3”.**

#### 3.3.1.1 Two Permanent Opening Method

One opening starting within 12” of the top of the boiler room and one starting within 12” of the bottom of the boiler room shall be provided. The openings shall be open directly to the outside or ducted directly to the outside.

When directly open to the outside or ducted to the outside by **vertical** ducts, each opening or duct shall have a minimum free open area of 1 in<sup>2</sup> per 4000 BTU total input rating of the boiler(s) in the room.

If ducted to the outside through **horizontal** ducts, each opening or duct shall have a minimum free area of 1 in<sup>2</sup> per 2000 BTU total input rating of the boiler(s) in the room.

#### 3.3.1.2 One Permanent Opening Method

One opening commencing within 12” of the top of the room shall be provided. The opening shall be directly to the outside or shall be ducted to the outside with a horizontal or vertical duct.

The opening or duct shall have a minimum free area of:

1 in<sup>2</sup> / 3000 BTU /hour of the total input rating of all appliances (boilers) in the room.

Additional area must be provided for other air consuming equipment in the room.

---

### 3.3.1.3 Mechanical Air Supply Systems

---

The combustion air supply may be provided by a mechanical air supply system. If utilized, the combustion air must be provided from the outside at a minimum rate of 0.35 ft<sup>3</sup>/min. for every 1000 Btu/hr. input for all appliances located in the space.

If exhaust fans are utilized, additional air shall be provided to replace the exhausted air.

Each boiler and other appliance must be interlocked to prevent operation when the mechanical air supply system is not in operation.

If the combustion air is provided by a buildings mechanical ventilation system, the system shall be sized to provide the specified combustion air in addition to the ventilation air requirements.

---

## 3.3.2 Louvers, Grilles, and Screens

---

### 3.3.2.1 Louvers and Grilles:

---

The required size of openings for combustion, ventilation, and dilution air shall be based on the net free area of each opening. Where the free area through a design of louver, grille, or screen is new, it shall be used in calculating the size opening required to provide the free area specified. Where the louver and grille design and free area are not new, it shall be assumed that wood louvers have a 25 percent free area, and met louvers and grilles have 75 percent free area. Non-motorized louvers and grilles shall be fixed in the open position.

---

### 3.3.2.2 Screens

---

Minimum Screen Mesh Size:

Screens shall not be smaller than 1/4" mesh.

---

### 3.3.2.3 Motorized Louvers:

---

Motorized louvers shall be interlocked with the appliance so they are proven in the full open position prior to main burner ignition and during main burner operation. Means shall be provided to prevent the main burner from igniting should the louver fail to open during burner startup and to shut down the main burner if the louver closes during burner operation.

---

### 3.3.2.4 Combustion Air Ducts

---

Combustion air ducts shall comply with the following:

Ducts shall be constructed of galvanized steel or a material having equivalent corrosion resistance, strength and rigidity.

Ducts shall terminate in an unobstructed space, allowing free movement of combustion air to the appliances.

Ducts shall serve a single space.

Ducts shall not serve both upper and lower combustion air openings where both such openings are used. The separation between ducts serving the upper and lower combustion air openings shall be maintained to the source of combustion air.

Ducts shall not be screened where terminating in an attic space.

Horizontal upper combustion air ducts shall not slope downward toward the source of combustion air.



For informational purposes, there are several codes that address the amount of air and/or size of the opening(s) in walls for combustion air.

NFPA 54, National Fuel Gas Code (ANSI Z223.1)

ASME CSD-1, Controls and Safety Devices for Automatically Fired Boilers

ASME Section VI, Recommended Rules for Care and Operation of Heating Boilers

BOCA, National Mechanical Code

#### WARNING:

**Do not locate air intakes where petroleum distillates, CFC's, detergents, volatile vapors or any other chemicals are present. Severe boiler corrosion and failure will result.**

### 3.3.3 Ducted Combustion Air

Ducted combustion air can be connected to the boiler air intake flange. Ducts shall be constructed of galvanized steel or a material having equivalent corrosion resistance, strength and rigidity.

Appendix B shall be used to determine the ducted combustion air system equivalent length. For typical ducted combustion air arrangements see Appendix E.

### 3.4 Venting Requirements

In order to properly vent this boiler, the installer must select and install a venting system that meets all requirements specified in this section, as well as following the instructions provided by the venting system manufacturer.

1. The venting system shall be designed and constructed in accordance with the National Fuel Gas Code, NFPA 54 / ANSI Z223.1 and applicable local building codes to develop a positive flow adequate to convey flue or vent gasses to the outdoors.
2. If this boiler is being installed in Massachusetts, follow the Massachusetts Code Instructions printed later in this section.
3. Consult the vent pipe manufacturer's instructions for vent system assembly and system specific installation requirements.
4. Vent pipe system shall be acceptable for use with boiler fuel type.
5. Vent pipe system shall be compatible either by directly connecting, or by using an adaptor, to the boiler vent connection.
  - a. This boiler is shipped with an AL 29-4C<sup>®</sup> Heat-Fab Saf-T-Vent connection.
  - b. Alteration of the boiler vent connection is prohibited.
6. Recommended flue system material is AL29-4C. Other materials may be used that meet the following requirements:
  - a. Flue system material shall be capable of continuous operation at 230°F or higher.
  - b. Flue system material shall have the same corrosion resistance to flue gas condensation as AL29-4C.
  - c. Flue system and material shall be certified to UL1738 - Venting Systems For Gas-Burning Appliances Categories II, III, and IV.
7. Do not reduce the diameter of the vent pipe. The vent pipe must not be smaller than the vent connector on the boiler.

8. Vent pipe system must be adequately supported at intervals no less than five (5) feet apart. The completed vent system must be rigid and able to withstand impacts without collapse.
9. The boiler's venting is Category IV (positive vent pressure, flue condensing), with regards to the National Fuel Gas Code, NFPA 54 / ANSI Z223.1.
10. Vent pipe system must be fully sealed.
11. Atmospheric venting is prohibited.
12. Appendix B shall be used to determine the vent system equivalent length.
13. It is permissible to run vent pipe through a vertical or horizontal chase provided minimum clearances to combustible materials are maintained.
14. The minimum clearance to combustible material is six (6) inches unless otherwise specified by the manufacturer.
15. The vent termination location is restricted as follows:
  - a. Minimum twelve (12) inches above grade plus normally expected snow accumulation or seven (7) feet above grade if located adjacent to public walkways. **DO NOT INSTALL** over public walkway where local experience indicates condensation or vapor from the boiler creates a nuisance or hazard.
  - b. Minimum three (3) feet above any forced air inlet located within ten (10) feet of the vent termination.
  - c. Minimum four (4) feet below, four (4) feet horizontally or one (1) foot above any door, window or gravity air inlet.
  - d. Minimum four (4) feet horizontally from electric meters, gas meters, regulators and relief valves. This distance may be reduced if equipment is protected from damage due to condensate or vapor by enclosure, overhangs, etc.
16. Use appropriately designed thimbles when passing through combustible walls or roofs.
17. Install fire-stops where vent passes through floors, ceilings or framed walls. The fire-stop must close the opening between the vent pipe and the structure.
18. Enclose vent passing through occupied or unoccupied spaces above the boiler with materials having a fire resistance rating at least equal to the rating of the adjoining floor or ceiling. Maintain minimum clearance to combustible materials.
19. Locate vent terminal above combustion air intake terminal (if used) and no closer than (1) foot horizontally.
20. Vertical venting requires flashing and a storm collar to prevent moisture from entering the structure.
21. Vertical vent termination must be at least two (2) feet plus the expected snow accumulation above roof penetration height.
22. This boiler has been certified with AL29-4C<sup>®</sup> venting. Select a vent material that is approved for use with condensing flue gasses.
23. Install vent system before installing air intake, water, gas or electrical connections.
24. For instances where the vent system manufacturer's instructions do not make a specification, refer to the below points.

- a. Make sure pipe and fittings are clean by swabbing with alcohol. Use Dow Corning 736 or 732 RTV, Polybar # 500 RTV or Sil-Bond 4500 or 6500 or seal vent pipe.
- b. Refer to the appropriate drawings in Appendix D of this manual to determine common acceptable configurations of the vent system.

**WARNING**

**Improper venting may result in property damage and the release of flue gasses that contain deadly carbon monoxide (CO) into the building, which can cause severe personal injury and/ or death.**

**WARNING**

**Do not use a barometric damper with this boiler. This is a positive pressure system. The use of a barometric damper may cause flue gasses to leak into the boiler room.**

### 3.4.1 Category II Venting

Category II venting is an engineered system and shall be designed by a qualified vent manufacturer and “APPROVED” by the local authority. The boiler manufacturer takes no responsibility for vent systems that create issues and or affect the performance of the boiler. All jurisdictional codes shall apply in addition to the following.

1. Common vents serving multiple boilers shall be designed for negative pressure so that flue gasses will not expel to the room through a boiler on standby.
2. Common venting with other appliances is prohibited.
3. Vent systems shall be designed to maintain a negative 0.001 iwc to negative 0.1 iwc draft at all times from the minimum firing rate to the maximum

- firing rate measured at the outlet of the boiler.
4. A mechanical draft fan may be required to maintain the required negative draft.
  5. Vertical venting is recommended. Other horizontal and vertical arrangements may be acceptable if proven by the vent manufacturers design calculations.
  6. It is recommended that combustion air be taken from the boiler room. Follow the guidelines in section 3.3 Other arrangements may be acceptable if proven by the vent manufacturers design calculations.
  7. It is recommended that a Carbon Monoxide detector be installed and interlocked to the boiler. Consult your local jurisdiction for additional requirements

Boiler Model	Flue Gas Flow, ACFM @40%XSA 200°F	Comb Air Req. SCFM @40%XSA 0°F	Flue Size
ARC 1000	301	220	6”
ARC 1500	452	330	8”
ARC 2000	603	441	8”
ARC 2500	753	550	10”
ARC 3000	904	661	10”
ARC 3500	1055	771	12”
ARC 4000	1206	881	12”
ARC 4500	1357	991	14”
ARC 5000	1507	1101	14”
ARC 5500	1658	1212	14”
ARC 6000	1809	1322	14”

**Table 4: Combustion Air and Flue Gas Requirements****WARNING**

**A poorly designed Category II negative vent system can produce positive pressures in the vent that can spill into the room and adjoining spaces that can cause severe personal injury and / or death.**

**3.4.2 Massachusetts**

The commonwealth of Massachusetts requires compliance with regulation 248 CMR 4.00 to 5.00 for installation of sidewall venting gas appliance as follow.

For all side wall horizontally vented gas fueled equipment installed in every dwelling, building or structure used in whole or in part for residential purpose, including those owned or operated by Commonwealth and where the side wall exhaust vent termination is less than seven (7) feet above finished grade in the area of the venting, including but not limited to decks and porches, the following requirements shall be satisfied.

1. **INSTALLATION OF CARBON MONOXIDE DETECTORS:** At the time of installation of the side wall venting gas fueled equipment, the installing plumber or gasfitter shall observe that a hard wired carbon monoxide detector with an alarm and battery back-up is installed on the floor level where the gas equipment is to be installed. In addition, the installing plumber or gasfitter shall observe that a battery operated or hard wire carbon monoxide detector with an alarm is installed on each additional level of dwelling, building or structure served by the side wall horizontal vented gas fueled equipment. It shall be the responsibility of the property owner to secure the service of a qualified licensed professional for the

installation of hard wired carbon monoxide detectors.

- a. In the event that the side wall horizontally vented gas fueled equipment is installed in a crawl space or an attic, the hard wired carbon monoxide detectors with alarm and battery back-up may be installed on the next adjacent floor level.
  - b. In the event that the requirements of this subdivision cannot be met at the time of completion of installation, the owner shall have a period of (30) days to comply with the above requirements; provided, however, that during said (30) day period, a battery operated carbon monoxide detector with an alarm shall be installed.
2. **APPROVED CARBON MONOXIDE DETECTORS.** Each carbon monoxide detector, as required in accordance with the above provisions, shall comply with NFPA 720 and be ANSI/UL 2034 listed and IAS certified.
  3. **SIGNAGE.** A metal or plastic identification plate shall be permanently mounted to the exterior of the building at a minimum height of eight (8) feet above grade directly in line with the exhaust vent terminal for the horizontally vented gas fueled heating appliance or equipment. The sign shall read, in print size no less than one-half (1/2) inch in size, "GAS VENT DIRECTLY BELOW. KEEP CLEAR OF ALL OBSTRUCIONS."
  4. **INSPECTION.** The state or local gas inspector of the side wall horizontally vented gas fueled equipment shall not approve the installation unless, upon inspections, the inspector observes carbon monoxide detectors and signage

installed in accordance with the provisions of 248 CMR 5.08(2)(a)1 through 4.

- a. EXEMPTIONS: The following equipment is exempt from 248 CMR 5.08(2)(a)1 through 4:
  - i. The equipment listed in chapter 10 entitled “Equipment Not Required To Be Vented” in the most current edition of NFPA 54 as adopted by the Board; and
  - ii. Product Approved side wall horizontally vented fueled equipment installed in a room or structure separate from the dwelling, building or structure used in whole or in part for residential purposes.
- b. MANUFACTURER REQUIREMENTS-GAS EQUIPMENT VENTING SYSTEM PROVIDED. When the manufacturer of Product Approved side wall horizontally vented gas equipment provides a venting system design or venting system components with the equipment, the instructions provided by manufacturer for installation of the equipment and the venting system shall include:
  - i. Detailed instructions for the installation of the venting system design or the venting system components; and
  - ii. A complete parts list for the vent system design or venting system.
- c. MANUFACTURER REQUIREMENTS-GAS EQUIPMENT VENTING SYSTEM NOT PROVIDED. When the manufacturer of a Product Approved side wall horizontally vented gas fueled equipment does not provide the parts for venting the flue gases, but identifies “special venting

systems”, the following requirements shall be satisfied by the manufacturer:

- i. The referenced “special venting system” instructions shall be included with the appliance or equipment installation instructions; and
- ii. The “special venting systems” shall be Product Approved by the Board, and the instructions for the system shall include a parts list and detailed installation instructions.
- d. A copy of all installation instructions for all Product Approved side wall horizontally vented gas fueled equipment, all venting instructions, all parts lists for venting instructions, and/or all venting design instructions shall remain with appliance or equipment at the completion of the installation instructions.

### 3.4.3 Combustion Air and Venting Requirements for Canada

---

Canadian Standard CAN/CSA-B149.1-05, Natural gas and propane installation code specifies venting systems and air supply for appliances in Section 8. Paragraph 8.1.4 states “Air supply shall be provided in accordance with Clause 8.4 when either an appliance or a combination of appliances has a total input exceeding 400,000 Btuh. Air supply is defined as combustion air, excess air, flue gas dilution air, primary air, secondary air, and ventilation air. The air supply requirements below are a summation of Clause 8.4 specific to this boiler.

### 3.4.3.1 Air Supply Requirements per CAN/CSA-B149.1-05 for Appliances having an input exceeding 400 MBH.

---

**Ventilation Air:** an opening for ventilation air at the highest point that opens to the outdoors shall provide Ventilation of the space. The cross sectional area of this opening shall be at least 10% of the area required for combustion air, but in no case shall the cross-sectional area be less than 10 in<sup>2</sup> (6500mm<sup>2</sup>).

**Combustion Air:** For combustion air where the air supply is provided by natural airflow from outdoors, in addition to the opening for ventilation air, there shall be permanent opening having a total cross-sectional free area of not less than 1 in<sup>2</sup> for each 30,000 BTU/hr. (70 mm<sup>2</sup> for each kW) of the total rated input of the boiler(s). The location of the opening(s) shall not interfere with the openings for ventilation air. Please refer to CAN/CSA-B149.1-05, Para. 8.4.4, for combustion air openings if there are natural draft, fan assisted or power draft assisted equipment in the space.

When an air supply duct is used to supply combustion air, its discharge opening shall be located where there is no possibility of cold air affecting steam or water lines or other temperature sensitive equipment.

### 3.4.3.2 Combustion Air Supply Dampers, Louvers, and Grilles

---

The free area of the combustion air supply opening shall be calculated by subtracting the blockage area of all fixed louvers, grilles or screens from the gross area of the opening.

Openings in a fixed louver, grille, or screen shall have no dimension smaller than 1/4" (6 mm).

No manually operated damper or manually operated adjustable louvers are permitted.

A motorized damper or louvers shall be interlocked so the burner(s) cannot operate unless the damper or louver is in the fully open position.

### 3.4.3.3 Mechanical Combustion Air Supply

---

When combustion air is supplied by mechanical means, an airflow sensing device shall be installed and wired into the safety limit circuit of the primary safety control to shut off the gas in the event of an air supply failure.

### 3.4.3.4 Appliance Venting per CAN/CSA-B149.1-05

---

Paragraph 8.9 of CAN/CSA-B149.1-05 addresses "Appliance Venting". Paragraphs 8.9 through 8.31 address many facets of flue gas vents, many of which do not apply to the this boiler, which is a Category IV listed appliance requiring the use of special venting systems as previously described.

#### NOTICE

**Please note that the information provided in this manual relative to the Canadian Standard is not meant to be all-inclusive. Reading the entire Standard is strongly suggested. The final approval of all system designs must be acceptable to the authority having jurisdiction.**

- Venting for Category IV appliances shall be as specified or furnished by the manufacturer of the listed appliance. This boiler is a Category IV appliance requiring the use of special vent that is certified.
- A special venting system shall be installed in accordance with the terms of its listing and the vent manufacturers certified installation manual.
- A flue gas vent or a vent connector shall not be installed in either a duct

or a shaft used for return air, hot air, ventilating air, or combustion air.

- An appliance that operates at a positive vent pressure shall not be connected to a venting system serving any other appliance. This boiler operates at a positive vent pressure.
- A factory-built chimney used for venting an appliance shall be certified.

### 3.5 Requirements

#### 3.5.1 Electrical

**WARNING**

**All electrical connections must conform to the National Electrical Code, ANSI / NFPA 70 and / or CSA C22.1 Electrical Code and all other State and Local codes.**

A separate electrical circuit must be run from the main electrical service with an over-current device/disconnect in the circuit. A service switch is recommended and may be required by some local jurisdictions. Locate the service switch such that the appliance can be shut off without exposing personnel to danger in the event of an emergency. See Table 5 for available voltages.

Table 5: Electrical Requirements				
<b>ARC1000</b>				
Voltage	FLA	CCA	MHP	MA
120/1/60	6.6	2.6	.46	4
<b>ARC1500</b>				
Voltage	FLA	CCA	MHP	MA
208-240/1/60	6.9	2.6	1.1	4.3
<b>ARC2000 to ARC3000</b>				
Voltage	FLA	CCA	MHP	MA
208-240/1/60	8.3	2.6	1.5	5.7
208-240/3/60	9.5	2.6	3	6.9
480/3/60	5.25	1.25	3.2	4
<b>ARC3500 to ARC4000</b>				
Voltage	FLA	CCA	MHP	MA
208-240/3/60	11.6	2.6	3	9
480/3/60	6.25	1.25	3.2	5
<b>ARC4500 to ARC6000</b>				
Voltage	FLA	CCA	MHP	MA
480/3/60	14.25	1.25	10.7	13
FLA = Full Load Amps : CCA = Control Circuit Amps : MHP = Motor Horse Power : MA = Motor Amps				

Connect field supplied safety limits or devices using proper terminals provided in boiler electrical cabinet. Refer to wiring diagram supplied with boiler for wiring information.

See Appendix H for sample-wiring diagrams. An as-built wiring diagram is included with every boiler when it ships. Contact a Thermal Solutions Representative or visit the website ([www.thermalsolutions.com](http://www.thermalsolutions.com)) for current wiring options.

### 3.5.2 Gas Supply Requirements

Refer to Table 6 for minimum and maximum gas supply pressure. When the gas supply pressure exceeds the maximum, an additional field supplied step down regulator will be required to reduce the supply pressure. For proper gas supply sizing refer to **Error! Reference source not found..**

#### NOTICE

The step down regulator shall be installed at least 60 pipe diameters from the boiler gas inlet manual shutoff valve. This will ensure proper gas regulation for establishing main flame reliably.

Model	Capacity (SCFH)	Inlet (npt)	Min. (iwc)	Max. (iwc)
ARC1000	1000	1	4	14
ARC1500	1500	2	4	14
ARC2000	2000	2	4	14
ARC2500	2500	2	4	14
ARC3000	3000	2	4	14
ARC3500	3500	2	7	14
ARC4000	4000	2	7	14
ARC4500	4500	2	7	14
ARC5000	5000	2	7	14
ARC5500	5500	2	7	14
ARC6000	6000	2	7	14

*Table 6: Gas Supply Requirements*

### 3.5.3 Sound Pressure Levels

Sound pressure levels were measured at 4-1/2' above the floor and 3' from the boiler at the front, rear and two sides. See Table 7 for decibel readings.

Table 7 Sound Pressure Levels

Model	Decibel Levels			
	Front	Rear	Tube Side	Right Side
ARC1500	67	60	61	63
ARC2000	67	60	61	63
ARC2500	62	62	66	61
ARC3000	62	62	66	61

### 3.5.4 Pump and Piping Requirements

Pump piping and system piping must meet the requirements of local codes and jurisdictions. Good engineering practices should be followed and considered for each piping system used.

It is advised that the circulating pump for each boiler be installed as close to the boiler as possible in the line to the return connection such that system water is pumped towards the boiler.

Installing circulating pumps so that the water is pumped away from the boiler is rarely recommended.

Means to eliminate air from the boiler/piping systems is a must. It is advised that an air separator be installed as close as practical to each boiler in the outlet pipe. Further, an air vent should be installed at all high points throughout the piping system.



It is recommended that a water meter be installed in the make-up water system to the boiler system. Scheduled recording of the water meter register will show an indication of a potential slow system leak in addition to providing insight into any system problems. Also, make-up water as well as water for the initial system fill should be provided through a water softener. Additionally, chemical treatment of the system water is advisable. Contact a qualified boiler water chemical treatment company for their recommendations. See section 3.8 for more information.

See Appendix G for boiler water flow pressure drop data and Appendix F for typical boiler piping arrangements.

#### 3.5.4.1 Water Flow Rates (Variable Primary Pumping Systems)

Variable primary pumping systems shall be capable of delivering no less than the minimum and no more than the maximum specified in Table 8 and Table 9 for each boiler connected in the system.

Model	Minimum Flow Rate		
	gpm	$\Delta P$ (ft)	High Fire $\Delta T$
ARC1000	19	.51	100F
ARC1500	29	.37	100F
ARC2000	38	.65	100F
ARC2500	48	.8	100F
ARC3000	57	1.15	100F
ARC3500	67	.42	100F
ARC4000	76	.42	100F
ARC4500	86	.42	100F
ARC5000	95	.5	100F
ARC5500	105	.58	100F
ARC6000	114	.67	100F

*Table 8 Minimum Water Flow Rates for Variable Primary Pumping*

Model	Maximum Flow Rate		
	gpm	$\Delta P$ (ft)	High Fire $\Delta T$
ARC1000	95	12.7	20F
ARC1500	143	9.2	20F
ARC2000	190	16.3	20F
ARC2500	238	20	20F
ARC3000	285	28.7	20F
ARC3500	333	11.33	20F
ARC4000	380	15.17	20F
ARC4500	428	25.17	20F
ARC5000	475	33.5	20F
ARC5500	523	37.25	20F
ARC6000	570	37.92	20F

*Table 9 Maximum Water Flow Rates for Variable Primary Pumping*

#### WARNING

**Do not use Table 8 or Table 9 to size a constant volume pump.**

#### 3.5.4.2 Water Flow Rates (Primary / Secondary Systems)

Each boiler connected to a secondary loop of a primary / secondary pumping system shall have a constant volume pump sized in accordance with Table 10 or Table 11.

Model	20 F $\Delta T$ Flow Rate			
	gpm	$\Delta P$ (ft)	High Fire $\Delta T$	Low Fire $\Delta T$
ARC1000	95	12.7	20F	4F
ARC1500	143	9.2	20F	4F
ARC2000	190	16.3	20F	4F
ARC2500	238	20	20F	4F
ARC3000	285	28.7	20F	4F
ARC3500	333	11.33	20F	4F
ARC4000	380	15.17	20F	4F
ARC4500	428	25.17	20F	4F
ARC5000	475	33.5	20F	4F
ARC5500	523	37.25	20F	4F
ARC6000	570	37.92	20F	4F

*Table 10 Water Flow Rates for Primary /  
Secondary Pumping 20F  $\Delta T$*

Model	40 F $\Delta T$ Flow Rate			
	gpm	$\Delta P$ (ft)	High Fire $\Delta T$	Low Fire $\Delta T$
ARC1000	48	3.18	40F	8F
ARC1500	71	2.3	40F	8F
ARC2000	95	4.08	40F	8F
ARC2500	119	5	40F	8F
ARC3000	143	7.18	40F	8F
ARC3500	166	2.67	40F	8F
ARC4000	190	3.17	40F	8F
ARC4500	214	6.25	40F	8F
ARC5000	238	7.92	40F	8F
ARC5500	261	9.25	40F	8F
ARC6000	285	9.42	40F	8F

*Table 11 Water Flow Rates for Primary /  
Secondary Pumping 40F  $\Delta T$*

### 3.5.4.3 Water Flow Rates (Constant Volume Primary Pumping Systems)

A constant volume primary pumping system shall be sized so that the flow rate specified in Table 12 can be maintained through each boiler connected to the system.

Model	Maximum Flow Rate		
	gpm	$\Delta P$ (ft)	High Fire $\Delta T$
ARC1000	95	12.7	20F
ARC1500	143	9.2	20F
ARC2000	190	16.3	20F
ARC2500	238	20	20F
ARC3000	285	28.7	20F
ARC3500	333	11.33	20F
ARC4000	380	15.17	20F
ARC4500	428	25.17	20F
ARC5000	475	33.5	20F
ARC5500	523	37.25	20F
ARC6000	570	37.92	20F

*Table 12: Water Flow Rates for Constant Volume Primary Pumping*

### 3.5.4.4 Water Flow Rates for Glycol

For glycol systems the gpm in Table 8, Table 9, Table 10, Table 11, and Table 12 will increase as specified in Table 13.

Glycol Concentration	GPM Percent Increase
50%	24%
30%	14%

*Table 13 GPM Increase for Glycol Systems*

## 3.6 Before Placing Boiler In Operation

### 3.6.1 Pre-Boil Out Flushing Of System

Much of the dirt and contamination in a new hot water system can be flushed out before the boil out of the system. First, flush the system of waste with clear water. The boiler and circulating pumps must be isolated through the successive zones of the system to waste, carrying metal shavings, dirt, pipe joint compound, etc. with it. Follow with a chemical flush.

#### WARNING

**Be CERTAIN that the chemicals used to flush and boil-out the boiler and system contain NO CHLORIDES. The boiler is fabricated with austenitic stainless steels that can be severely damaged when exposed to chlorides.**

The removal of pipe chips and other debris from the system before opening the isolation valves to the boiler and pumps will help to protect this equipment from damage by such debris.

In combination with system contamination, bacteria from ground water boiler water may produce objectionable odors, sometimes resembling the odorant used in natural gas. It is important to keep these fumes from air intakes that would distribute them throughout the building.

### 3.6.2 Boil Out Procedure

#### WARNING

The boil out procedure outlined must be performed by, or under the direct supervision of, a qualified technician. The chemicals used present a hazard of burns and physical injury if mishandled. Always use a suitable facemask, goggles, protective gloves, and garments when handling caustic chemicals. Do not permit the chemical to come into contact with skin or clothing. Always follow the safety precautions on the container's label. Add chemicals slowly and in small amounts to prevent excessive heat and agitation.

The boil out of the boiler and system is neither difficult nor expensive. The chemicals needed for cleaning are readily available. Tri-sodium phosphate and sodium hydroxide (lye) are the most commonly used chemicals. Be certain the chemicals used contain NO CHLORIDES. Use only one type of solution in the system. The amount of chemical required will vary according to conditions, but one pound per fifty gallons of water is suggested.

Fill the system with this solution, venting all air. Then, with the circulating pump running, bring the system to design or operating temperature. After circulating water for two to three hours, the system should be drained completely, and refilled with fresh, softened water see section 3.8. Usually enough of the cleaning solution will adhere to the piping to result in an alkaline solution satisfactory for operation. A pH reading between, 8.3 – 10.5 is preferred. If necessary, to increase the pH, a small amount of cleaner may be added.

### 3.6.3 Replacement Boiler Installations

Clean or replace all system piping and heating units.

Arrange for chemical or mechanical cleaning of the entire system. A chemical treatment company should be consulted for the proper means of any chemical cleaning. Replace any piping that is deteriorated beyond safe or cleanable condition.

Flush the system clean, being certain to isolate the boiler.

#### WARNING

**Do not flush the system through the boiler.**

For some old systems, there is a reluctance to clean the piping because of possible leaks occurring in badly corroded lines. Should the customer refuse cleaning, it is necessary to install filtration equipment. Install either a fibrous filter or a centrifugal filter in the boiler return piping. This will collect and remove sediment from the system. A booster pump may be required to overcome the additional pressure drop introduced in the line by the filter. When filling the system, provide chemical treatment as outlined in Section 3.8.

Failure to properly clean the system or to install mechanical sediment removal equipment can result in tube blockage and severe corrosion plus damage to pumps, controls, and air removal devices.

Inspect, repair as necessary, or replace system air control devices.

Install gauge glasses on air expansion tanks and install a tank fitting in the system connection to the tank.

Install a strainer in the boiler return piping.

### 3.7 Draining and refilling the boiler & system

If the system is drained and then refilled, chemical treatment is essential to treat the raw water. Use only clean, softened water.

### 3.7.1 Filling The System

---

#### WARNING

**Use only clean, softened, and treated water. Chemical treatment of the raw water is essential when filling or refilling the system see section 3.8.**

### 3.7.2 Hydrostatic Test Of Boilers And System

---

After completing the boiler and burner installation, the boiler connections, fittings, attachments and adjacent piping must be inspected for leaks by filling the unit with water. The pressure should be gradually increased to a pressure just below the setting of boiler safety relief valve(s).

Remove the boiler tube access panels (see dimensional drawing in the boiler manual). Inspect the tube to header joints to be certain that all tube fittings are sealed. This is necessary because, although the boiler is hydrostatically tested at the factory, minor leaks in fittings and at attachments can develop from shipping vibration or from installation procedures. Replace tube access panels before proceeding to start boiler.

## 3.8 Boiler Water Treatment

### 3.8.1 Purpose of water treatment

---

Water treatment is required for satisfactory operation of the boiler. It must be devised to prevent depositing of scale and corrosion from acids, oxygen and other such harmful elements that may be in the water supply. A qualified water treatment chemist should be consulted and the water systematically treated.

“Hot water systems must operate with a pH above 8.5. A system that has a pH below 8.5 will usually develop the following problems:

1. Gas formation (air trouble)
2. Pump seal and gland problems
3. Air vents sticking and leaking

4. Frequent relief valve operating
5. Piping leaks at joints

(American Boiler Manufacturers Association [ABMA], 2005. Boiler Water Quality Requirements and Associated Steam Quality for Industrial / Commercial and Institutional Boilers)”

### 3.8.2 Objectives

---

The basic objectives of water treatment are:

1. Prevent the accumulation of scale and deposits in the boiler.
2. Remove dissolved gases from the water.
3. Protect the boiler against corrosion.
4. Maintain the highest possible boiler fuel efficiency.
5. Decrease the amount of boiler down time from cleaning.

### 3.8.3 Water softener

---

It is highly recommended that a zeolite water softener be used for all make-up to the boiler. It is intended that this be used in addition to the chemical treatment of the boiler. Water softening removes calcium and magnesium, the primary causes of hard boiler scale.

### 3.8.4 Continuous Monitoring

---

Water treatment should be checked and maintained according to Table 15 whenever the boiler is operating. The boiler operator should be sure that the boiler is not operating for long periods without proper water treatment.

Water treatment may vary from season to season or over a period of time. Therefore, the water treatment procedure should be checked not less than four times a year and possibly more frequently as the local water conditions may indicate.

See Table 14 for examples of typical chemical agents found in untreated water along with their potential effects.

<i>Table 14: Chemical Agents and Effects</i>	
Compound	Effect
Calcium Carbonate, (CaCO <sub>3</sub> )	Soft Scale
Calcium Bicarbonate (CaHCO <sub>3</sub> )	Soft scale, CO <sub>2</sub>
Calcium Sulphate (CaSO <sub>4</sub> )	Hard Scale
Calcium Chloride (CaCl <sub>2</sub> )	Corrosion
Magnesium Carbonate (MgCO <sub>3</sub> )	Soft Scale
Magnesium Bicarbonate (MgHCO <sub>4</sub> )	Corrosion, Scale
Magnesium Sulphate (MgSO <sub>4</sub> )	Corrosion
Silicon Dioxide (SiO <sub>2</sub> )	Hard Scale

It should be noted that water boilers may well need chemical treatment for the first filling plus additional periodic chemical treatment, depending on system water losses and the makeup requirements.

All water introduced into the boiler should be softened and should include an oxygen scavenger like sodium sulfite. This is required to remove dissolved oxygen from the water. Dissolved oxygen will cause severe system corrosion.

Dissolved Oxygen	< 0.007 ppm	
Total Iron	≤ 0.1 ppm	
Total Copper	≤ 0.05	
Total Hardness	≤ 9 ppm	≤ 0.5 grains/gal
pH	8.3 – 10.0	
Nonvolatile TOC	< 1 ppm	
Oily Matter	< 1 ppm	

*Table 15 Recommended Feed Water Limits*

<b>CAUTION</b>
<b>Thermal Solutions Standard Warranty does not cover problems caused by oxygen contamination of boiler water.</b>
<b>Thermal Solutions Standard Warranty does not cover problems caused by scale build-up.</b>
<b>When using Glycol products, all Glycol manufacturers' requirements, including rust inhibitors, must be adhered. Max 50% Glycol.</b>

<b>WARNING</b>
<b>Chemicals used in treating boiler water are toxic and/or harmful. Always use protective clothing and equipment when working with/near chemicals. Contact local authorities to determine if treated boiler water can be discharged into local waste water system.</b>

## 4 SYSTEM START-UP


This Section applies **ONLY** to the ARC1000 through ARC3000


### WARNING


Completely read, understand and follow all instructions in this manual, Concert Boiler Control manual, and all other component manuals supplied with this boiler before attempting start-up.

#### 4.1 Concert Boiler Control Display Navigation – This Section applies **ONLY** to the ARC1000 through ARC3000

This boiler is equipped with a color touch screen display, which presents information and control options in a page manner. Pages are arranged in a tree structure through which the user navigates up and down to arrive at the desired function. The page descriptions and a complete list of the available control parameters are provided in a separate instruction manual for the Concert boiler control (Also supplied with the boiler).

Most pages have a Home button  in the top-left corner of the screen. The Home button returns the user to the Home page to view real time operation of the boiler.

The back button  returns the user to the previous page.

A padlock  icon will be shown on the screens that require the user to enter a password to change the parameter. An unlocked padlock indicates the correct password has been entered to change the parameter.

The user can access the following icons from the Home screen: Menu, Info, Status, Adjust, and Help. It is important that the user become familiar in accessing additional icons that are not shown on the home screen page.

### NOTICE

Refer to the Concert Boiler Control manual for detailed instructions on the use of the hydronic control and display.

#### 4.2 System Check:

1. Verify that the venting, water piping, gas piping and electrical system are installed properly. Refer to installation instructions contained in this manual.
2. Confirm all electrical, water and gas supplies are turned off at the source and the chimney/vent is clear of obstructions. If boiler is controlled by an external control system, this system must be temporarily disconnected. The local boiler controls should be allowed to operate the boiler.
3. Confirm that all manual shut-off valves between the boiler and gas supply are closed.

#### 4.3 Power the Boiler:

Turn on the electrical supply to the boiler and circulation system at fused disconnect switch. Ensure that the circuit breaker switch is in the “ON” position.

#### 4.4 Power the Circulators:

Turn system circulators on and purge air from the boiler and system piping.

#### 4.5 Pressurize the Fuel System:

1. Open the manual gas shut-off valves located upstream of the field supplied gas

- regulator. Do not open manual gas valve directly outside the boiler jacket.
2. Purge gas line of air.
  3. Open manual ball valve outside boiler jacket. Confirm that the supply pressure to the manual ball valve tapping outside the boiler jacket conforms to Table 6 for maximum and minimum supply pressure.
  4. Repeat steps 2 and 3 for boiler gas train components.

#### **4.6 Boiler Commissioning: This Section applies ONLY to the ARC1000 through ARC3000**

All of the installation instructions found in sections 1 through 3 shall be completed before commissioning the boiler.

### **DANGER**

**Failure to properly adjust excess air will result in unsafe levels of carbon monoxide. Variations in venting or combustion air pressure and temperature will change excess air. Adjust excess air levels so that variation in venting or combustion air pressures and temperatures caused by change of seasons, wind conditions, opening or closing of boiler room doors or windows do not cause the boiler to operate with carbon monoxide concentration above 400 parts per million.**

1. Identify boiler water, gas, and electrical connections, and other safety controls.
2. Locate manometer pressure taps for pressure measurements in the following areas:
  - a. Supply gas pressure (ball valve tapping outside of boiler top jacket panel)
  - b. Stack or flue outlet pressure
3. Install a gas analyzer probe within 6" above the boiler flue gas outlet.
4. Verify the high temperature limit (auto reset) is set to 200 °F. (1000 only)
5. Verify the high and low gas pressure switch limits.
  - a. High gas pressure switch at 1.0" w.c.
  - b. Low gas pressure switch at 3.0" w.c.
6. **Menu > Operation > Auto / Manual Rate Control > Manual** (76 password required)
7. Switch boiler circuit breaker in the control panel to the ON Position (1000 only).
8. Close the manual gas valve between the automatic gas valve and the blower inlet.
9. Cycle the boiler. The boiler should lockout on gas pressure failure. In this case it should be the low gas pressure switch.
10. Reset the low gas pressure switch and gas pressure lockout.
11. Increase the high gas pressure switch setting to 14" w.c.
12. Cycle the boiler. The boiler should lockout on flame failure or ignition failure. (Boiler may recycle once if there was an ignition failure. Repeat step 12.)
13. Reset the flame failure lockout and decrease the high gas pressure setting to 1" w.c.
14. Cycle the boiler. The boiler should lockout on gas pressure. In this case it will be the high gas pressure switch.
15. Open the manual gas valve between the automatic gas valve and the blower inlet.
16. Reset the high gas pressure switch and gas pressure lockout.
17. Cycle the boiler. The boiler should establish main flame.



18. If flame is not established reset the flame failure lockout and repeat step 17. (*Consult with the factory for assistance if flame cannot be established after 3 attempts.*)
19. Check that O<sub>2</sub> levels are within a safe operating range. (4.5% to 7.0%)
20. **Menu > Operation > High/Low > High > Back Arrow** (76 password required)
21. Once boiler has reached high fire rate, check that O<sub>2</sub> levels are within a safe operating range. (4.5% to 7.0%)
22. Adjust supply gas pressure between 4" w.c. and 14" w.c. as measured at the ball valve tapping outside of the boiler top jacket panel.
23. Adjust the O<sub>2</sub> level so that it is within 4.5 to 7.0 % at high fire with all jacket doors installed and front cabinet door closed.
  - a. For best efficiency, standard O<sub>2</sub> should be set to 4.5% to 4.6%.
  - b. For boilers specified to be less than 20ppm NO<sub>x</sub> adjust the O<sub>2</sub> level within 6.5% to 7.0%.
  - c. For boilers specified to be less than 9ppm NO<sub>x</sub> adjust the O<sub>2</sub> level within 7.0% to 9.0%.

*Note: High Fire O<sub>2</sub> levels are adjusted with the gas shutter valve located on the outlet of the gas valve.*

- i. Turn adjustment screw toward the 'Plus (+)' side to increase gas flow (decrease O<sub>2</sub> level).
  - ii. Turn adjustment screw toward the 'Minus (-)' side to decrease gas flow (increase O<sub>2</sub> level)
24. **Menu > Operation > High/Low > Low > Back Arrow** (76 password required)
  25. Verify the O<sub>2</sub> level is within +/- 0.3% of the O<sub>2</sub> level set at high fire with all

jacket doors installed and front cabinet door closed. (Consult the factory for assistance if the O<sub>2</sub> levels are not within +/- 0.3% from high fire to low fire.)

#### Warning

**Improper adjustments to the low fire offset adjustment can lead to rough light-offs and nuisance flame failures.**

26. Verify O<sub>2</sub> repeatability by commanding the boiler to high fire and low fire as many times as required, repeating steps 20 to 26 as necessary.



*Figure 7: High Fire Adjustment on the Main Gas Valve Regulator (This valve applies ONLY to ARC1000 through ARC3000)*

27. Once the boiler is operating within the specified high and low fire ranges, record emissions, flue draft, and other important data on the installation and startup report, see Appendix C.

28. Perform tests on each of the components listed in Table 16.

#### **4.7 Finish Commissioning the Boiler: This Section applies ONLY to the ARC1000 through ARC3000**

---

Reconnect any wires from the external control system, if applicable.

1. Perform an operation test of the external control system.
2. Place system control back in normal operation, if necessary.
3. Place the boiler into automatic mode.  
Menu > Operation > Auto / Manual Rate Control > Automatic (76 password required)

#### **4.8 Re-Starting After Prolonged Shutdown**

---

Use the following recommendations prior to re-starting the heating system after prolonged shutdown.

1. Perform Pre-Start-Up Inspection by checking all gas, water, air intake and venting connections to ensure proper, leak-free connections and that the water and gas lines has been cleaned completely.
2. Ensure that combustion air piping, vent piping, and terminations are free of obstructions.
3. Inspect the boiler for damage and loose wire connections.
4. Remove all flammable material present in the vicinity of the boiler.

## 4.9 Testing of Controls and Safety Devices

Prior to placing the boiler in operation, the installing contractor or other responsible personnel must perform safety and control device limit tests to ensure proper operation of the appliance. Refer to Table 16 for recommended method(s) of carrying out these safety limit devices tests.

Component	Test Method(s)	After Lockout Annunciation	Actual Alarm Message
High Gas Pressure Switch	Close the manual gas valve between the gas valve and air inlet. Cycle boiler.	Manually reset the Concert Boiler Control and switch. Adjust the switch to its normal setting.	Hard Lockout. Gas Pressure Switch
Low Gas Pressure Switch	Increase the setting of the switch until the switch trips.	Manually reset the Concert Boiler Control and switch. Adjust the switch to its normal setting.	Hard Lockout. Gas Pressure Switch
Blocked Condensate Switch	Disconnect one wire of the blocked condensate switch. Cycle the boiler.	Re-connect wiring to the blocked condensate switch. Reset blocked condensate switch lockout.	Hard Lockout Blocked Condensate Switch
Vestibule Thermal Fuse	Disconnect one wire of the vestibule thermal fuse. Cycle the boiler.	Re-connect wiring to the blocked condensate switch. Reset vestibule thermal fuse lockout.	Hard Lockout Vestibule Thermal Fuse
Low Water Cutoff	With the boiler running push and hold the LWCO test button until the boiler control shuts down the main burner.	Manually reset the Concert Boiler Control and reset the LWCO.	Hard Lockout. Low Water Level
Auto Reset (High Temp) Limit (1000 only)	With the boiler running lower the setting of the limit so that the boiler control shuts down the main burner.	Adjust the limit to its normal setting.	High Limit Auto Reset
Water Flow Switch	Reduce the water flow rate with a manual shutoff valve until the boiler shuts down.	Adjust manual valve to normal position.	Low Water Flow

## 4.10 Ignition Failure

---

After the first ignition failure, the boiler goes into a hard lockout and a manual reset of the Concert Boiler Control is required to restart the boiler. The boiler will then attempt to light off after it has completed its post-purge process.

### **DANGER**

**Contact the boiler manufacturer or a qualified heating service technician if the boiler has failed to light consecutively three times after initially resetting the Concert boiler control.**

**5 Service, Maintenance, and Inspection**

**5.1 General Maintenance:**

1. Follow any checks and/or inspections that may be required as specified in the component manufacturers' instruction manuals.
2. Repair or replace any defective components immediately.
3. The following service procedures are required for proper and safe boiler operation.

<b>DANGER</b>
This boiler uses flammable gas, high voltage electricity, moving parts, and very hot water under high pressure. Assure that all gas and electric power supplies are off and that the water temperature is cool before attempting any disassembly or service.
More than one gas shut-off valve and electrical disconnect switch are used on the boiler. Assure that all gas valves and electrical disconnect switches are off before attempting any disassembly or service.
Do not attempt any service work if gas is present in the air in the vicinity of the boiler. Never modify, removed or tamper with any control device.
Do not use matches, candles, open flames or other ignition source to check for leaks.

<b>WARNING</b>
This boiler must be serviced and repaired by skilled and experienced service technicians only.
If any controls are replaced, they must be replaced with identical models supplied by Thermal Solutions.

Read, understand and follow all the instructions and warnings contained in all the sections of this manual. The instructions and warnings contained in all of the component instruction manuals.

If any electrical wires are disconnected during service, clearly label the wire and ensure that the wires are reconnected properly.

Never jump out or bypass any safety or operating control or components of this boiler.

Assure that all safety and operating controls and components are operating properly before placing boiler back in service.

<b>WARNING</b>
The service instructions contained in this manual are in addition to the instructions provided by the manufacturer of the boiler components. Follow component manufacturer's instructions. Component manufacturer's instructions were provided with the boiler. Contact component manufacturer or Thermal Solutions for replacement if instructions are missing. Do not install, start up, operate, maintain or service this boiler without reading and understanding all of the component instructions. Do not allow the boiler to operate with altered, disconnected or jumpered components. Only use replacement components identical to those originally supplied by Thermal Solutions.
All cover plates, enclosures, and guards must be in place at all times, except during maintenance and servicing.

### 5.1.1 DAILY:

---

1. Make visual inspection of gauges, monitors, and indicators and record readings in boiler log.
2. Make visual check of instrument and equipment settings against factory recommended specifications.
3. Check operation of probe type low water cutoff(s) to ensure control is functioning.
4. Check gas train for gas leaks and water piping for any leaks.
5. Confirm boiler area is free of combustible materials and that there is nothing obstructing air intake and vent.

### 5.1.2 WEEKLY:

---

1. Check combustion safety controls for flame failure (or other alarm messages).
2. Check all limit controls and low water cutoff as described above.
3. Check condensate drains for any obstructions.
4. Check carbon monoxide level in flue products.

### 5.1.3 MONTHLY:

---

1. Check high and low gas pressure interlocks. Refer to manufacturer's instructions for correct procedure.
2. Check proper operation of safety relief valve.
3. Check water quality and correct if needed.
4. Inspect boiler air filter.

### 5.1.4 ANNUALLY:

---

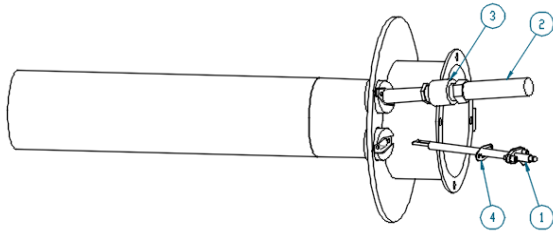
1. The flue gas passages and the exterior surfaces of the boiler tubes should be inspected at least once annually. Any accumulation of soot or debris should be thoroughly cleaned out.

2. If inspection of the boiler tube surfaces reveals a build-up of soot (carbon), the tube surfaces should be thoroughly brushed. Failure to do so may result in reduced efficiency, fire and asphyxiation hazards.
3. The boiler pressure vessel and piping should be checked annually.
4. Inspect the ignition rod for carbon build up.
5. Inspect lens of the ultra-violet (uv) scanner and remove any debris with soft cloth and make sure that hole is clear from scanner to burner.
6. Replace air filter.

### 5.2 Ignition Assembly Cleaning

---

1. Disconnect power and shut off the external manual gas valve to the boiler prior to removing the ignition assembly.
2. When removing the igniter, extra caution must be taken to prevent damaging the ceramic insulator.
3. Remove any excess oxide deposits from the surface of the igniter with steel wool or emery cloth. Do not use sandpaper.
4. Inspect the ceramic insulator for cracks, and if necessary, replace the igniter. After each inspection of the igniter, replace gasket and apply anti-seize compound to mounting screws prior to reinstalling them.
5. Ensure that igniter electrode spacing is within 1/8 inch.
6. When reinstalling the igniter after inspecting it, make sure there is a 3/8 inch gap between the igniter and the burner surface.



*Figure 8: Ignition Assembly*

- 1. Igniter
- 2. Ultra-Violet (UV) Scanner
- 3. ½" Heat Insulator
- 4. Igniter Gasket

3. Be careful not to damage or disturb the insulation inside of the heat exchanger.

### **5.3 Burner Assembly Cleaning**

---

1. After disconnecting power to the boiler, remove the boiler's furnace door. For part identification, refer to the "Parts Manual".
2. Clean around the burner assembly by blowing compressed air over the surface of the burner to remove lint and debris accumulation. Be careful when cleaning the burner assembly, to avoid damaging the metal mesh burner surface.
3. If the burner or the burner gasket shows any visual deterioration or corrosion signs, replace it immediately.
4. After replacing the burner or burner gaskets, check for proper operation by performing combustion analysis, as well as checking for gas leakage around the burner mounting and blower transition pieces.

### **5.4 Heat Exchanger Cleaning**

---

1. Perform visual inspection of both boiler flue passes, and remove any debris from the surfaces of the heat exchanger.
2. If necessary, brush the tubes of the heat exchanger using non-abrasive, non-metallic bristle brush.

## 5.5 Tube Replacement Procedure

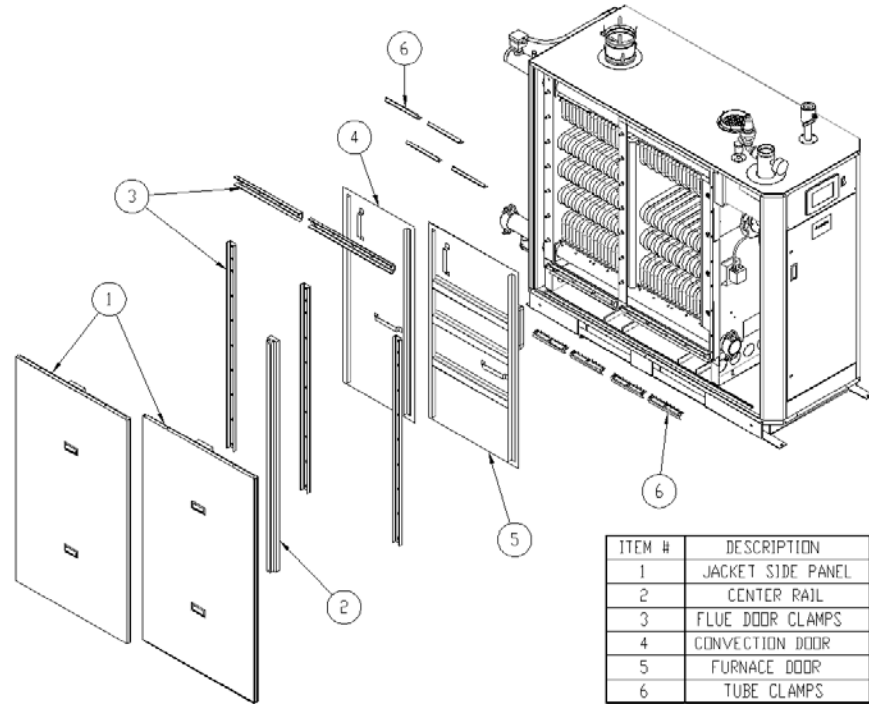
---

### NOTICE

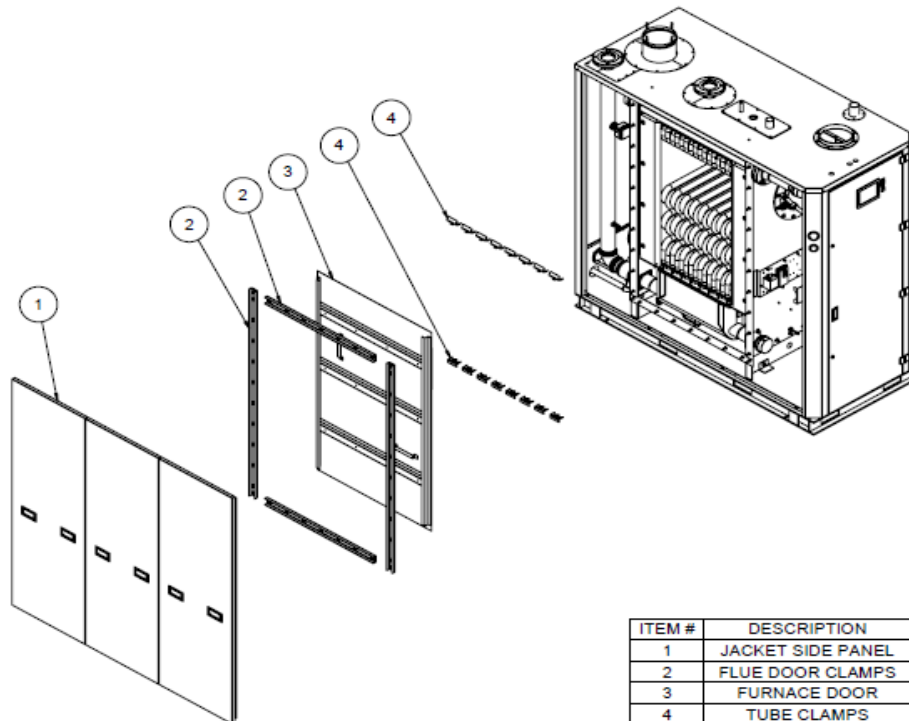
**Performing a regular boiler inspection will prolong the life of the heat exchanger, and ensure optimal function and energy efficiency. For best practices, adhere to the general guidelines outlined in the service and maintenance section of this manual.**

1. Inspect the boiler. Use the following steps to identify a potential tube leak and to minimize possible damage to the boiler and other equipment as a result of tube failures.
  - a. Shut off power to the boiler immediately from the external, dedicated electrical disconnect.
  - b. Confirm that any water leakage is not the result of a blocked condensate drain line.
  - c. Confirm that any water leakage is not the result of a blocked condensate drain line.
  - d. Remove the boiler's left side jacket panels and flue collector access panels as shown in Figures 9, 10 and 11.
  - e. Visually inspect the burner and furnace pass insulation for water damage. If significant water damage to the insulation or burner is observed, contact the manufacturer.
  - f. Identify any leaking tubes.
  - g. Isolate and drain the boiler completely.
2. Use the proper tools. Use the following tools to remove and replace leaking boiler tubes:
  - a. Tube Puller (P/N 106019-02)
  - b. Tube Driver (P/N 106019-01)
  - c. Sledgehammer (steel head, approximately 3 lb)

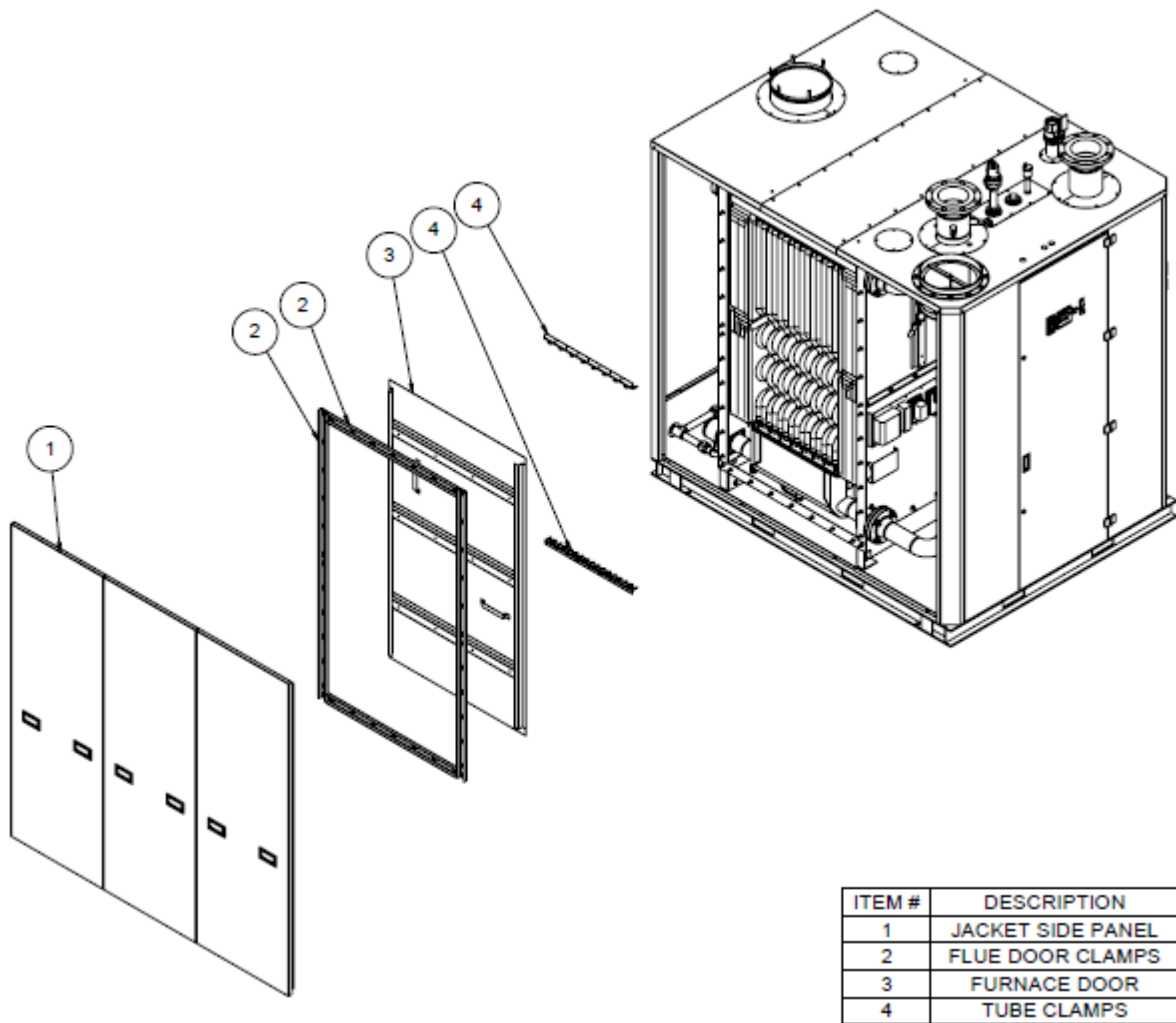




*Figure 9: Panel Removal in Preparation for Tube Inspection-ARC1000*



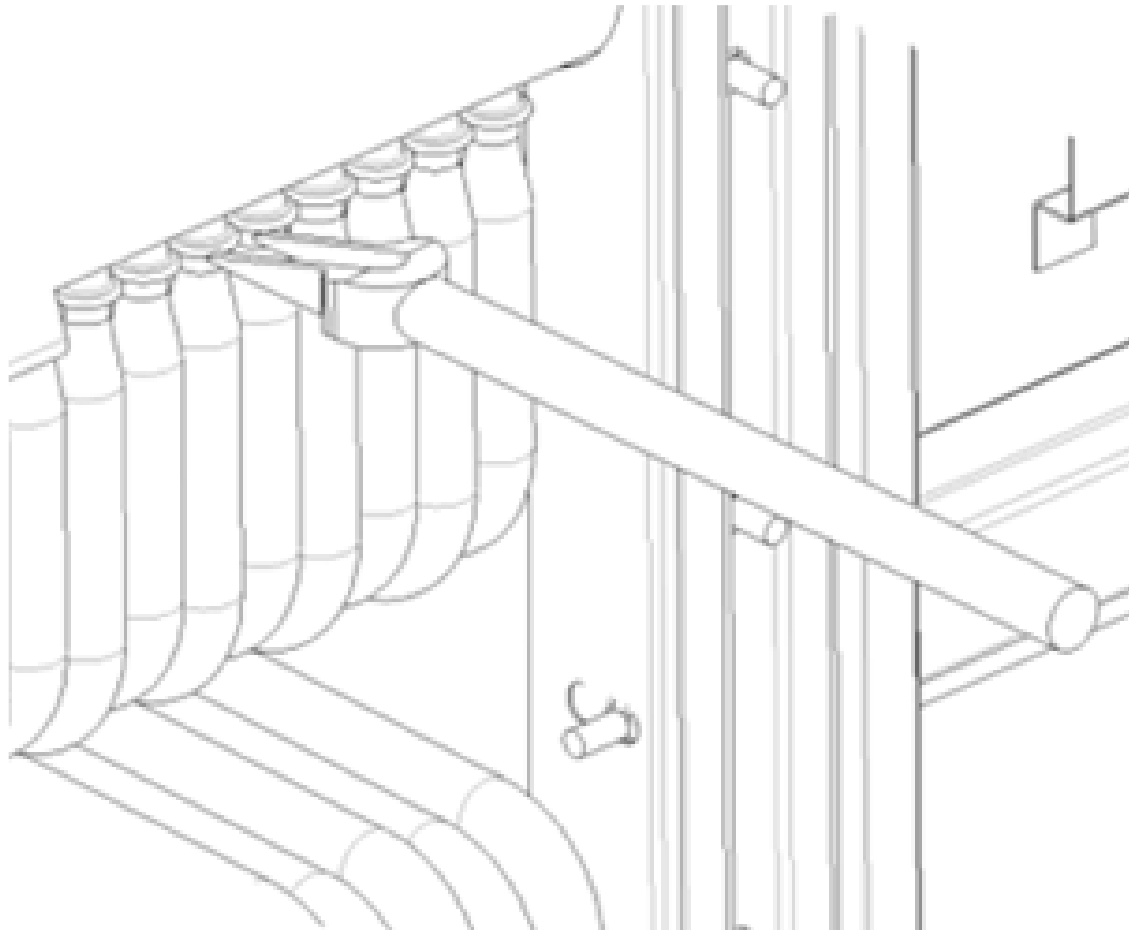
*Figure 10: Panel Removal in Preparation for Tube Inspection-ARC1500-ARC3000*



**Figure 11: Panel Removal in Preparation for Tube Inspection-ARC3500-ARC6000**

Note: Tubes are accessed and serviced from both sides of the ARC3500-ARC600 Boilers. (Right side exploded view not shown.)

1. Loosen tube-ends. Insert tube puller between the tube-end and header. Apply pressure to the puller and strike the side of the tube two or three times with a hammer to help loosen the tube-end in the upper and lower header.
2. Pull lower tube end. Wedge the tube puller under the flange of the tube. Drive the tube puller with several blows with a hammer on the end of the handle. Alternate with downward blows to lift tube-end.
3. Clear tube-end from the header. Continue driving wedge under and leveraging flange up until it pops the end of the tube free from the hole in the header.
4. Pull upper tube-end. Repeat the procedure to pull the tube-end of the same tube from the upper header.



*Figure 12: Tube Puller Insertion*

5. Prepare the headers and replacement tubes. Before placing a new tube into the header, clean the holes by wiping gently with emery cloth to be sure that there are no burrs. Clean the replacement tube-ends of any rust or debris. With a small brush, apply a thin coating of gray pipe dope around the inside of the hole. Pipe dope may also be applied to the tube-end. Cutting oil may be mixed with the pipe dope for easier application.

6. Insert both ends of the tubes into the headers. Insert the lower tube-end into the bottom header first. Then insert the top tube-end into the top header. Insert all replacement tubes before driving them.
7. Drive the upper and lower tube-ends. DO NOT drive the tube-ends down to the flange. With the driver tool positioned on the flange, strike the end of the driver with hammer. After a few hits, the feel of the strike will become solid. The tone will also change from a “ting” sound to more of a “tong” sound. This indicates the tube has seated.

#### CAUTION

**Do Not Overdrive Tubes! Overdriving tubes can cause damage to the tubes and boiler header holes. Use only approved Thermal Solutions tube driver and specified hammer. The end-formed tube fitting is designed to deform if overdriven to minimize damage to the vessel tube holes.**

8. Reinstall the tube clamps. Replace the nuts and flat washers if damaged in any way. Use brass nuts only! Tighten the nuts until snug. Do not try to compress the tube-ends into the holes with the clamps, because the clamps might break or the stud might shear.
9. Refill the boiler. Fill the unit with water and ensure that there is no leakage at the replacement tube-ends before reinstalling the flue collector panels.

#### WARNING

**If a leak is detected after a replacement tube has been installed, pressure in the boiler must be reduced to zero before adjusting tube(s). Adjusting tubes under pressure could result in serious personal injury.**

10. Reinstall all flue access doors, door clamps, and jacket panels.
11. Perform startup check prior to putting boiler back into operation.

## 5.6 Safety and Operating Controls

All of the safety control devices listed in Table 17 are logically linked to the Concert Boiler Control that supervises the sequence of operation of the boiler for safe and efficient operation. It does so by ensuring proper light off and firing of the main burner and if need be, will immediately cut-off gas supply to the main burner when gas pressure, water temperature, water flow or another critical attribute is outside of the operational settings. It also varies the combustion rate in real time to meet the desired load of the system.

### WARNING

**Do not install, operate, service or repair any components of this equipment unless you are qualified and fully understand all requirements and procedures. Trained personnel should refer to those who have completed Thermal Solutions Service School training specific to this product.**

Table 17: Safety and Operating Controls

Component	Function
Power Switch	If this switch is in the off position, power is interrupted to the control circuit of the boiler, which prevents the boiler from operating. If the switch is in the on position, power is supplied to the control circuit.
Automatic Reset Operating Aquastat	If the boiler water temperature exceeds the adjustable set point, power is interrupted to the control circuit of the boiler, which prevents the boiler from operating. When the boiler water temperature drops below the set point minus the adjustable differential setting, power is again supplied to the control circuit.
Manual Reset High Limit Aquastat	If the boiler water temperature exceeds the adjustable set point, power is interrupted to the control circuit of the boiler, which prevents the boiler from operating. Power is interrupted until the control is manually reset pressing the control's reset button. When the button is pressed, power will again be supplied to the control circuit, assuming that the boiler water temperature has dropped below the setpoint minus the differential setting.
Water Flow Switch	If the water flow through the boiler drops below the fixed flow rate required to move the control's paddle enough to close the control's contacts, power is interrupted to the control circuit, which prevents the boiler from operating. When the water flow rate increased, the paddle closes the control's contacts and power is supplied to the control circuit.
Pressure / Safety Relief Valve	If the pressure inside the boiler exceeds the fixed set point, the valve opens mechanically and discharges water. The valve remains open until the pressure inside the boiler drops below the set point.
High and Low Gas Pressure Switches	If the gas pressure reaches a point above or below the adjustable set point, the contacts of the switch open and power is interrupted to the control circuit that prevents the boiler from operating. Power is interrupted until gas pressure is between the high and low gas pressure set points and the control is manually reset moving the switch to the reset position. The switches will not reset until the gas pressure is within the set point parameters.
Minimum Air Pressure Switch	If the differential air pressure drops below the fixed set point, the contacts of the switch open and power is interrupted to the control circuit, which prevents the boiler from operating. Power is interrupted until air flow/pressure increases so that contacts close.
Maximum Air Pressure Switch	If the differential air pressure exceeds the fixed set point, the contacts of the switch open and power is interrupted to the control circuit, which prevents the boiler from operating. Power is interrupted until air flow/pressure decreases below the setting so that the contacts close.

## 5.7 Troubleshooting

Refer to the troubleshooting section in the Concert Boiler Control manual on how to navigate the Limit String Status screen that shows an active safety limit status and for an in-depth guide to all the possible lockouts as well as recommended corrective actions for restore boiler operation.

INDICATION	POSSIBLE CAUSE	CORRECTIVE ACTION
Boiler is not responding to a call for heat, "Status" and "Priority" show "Standby".	Boiler is not seeing Enable/Disable of Domestic Demand Input.	Check wiring for loose connections or wiring errors. If Domestic Demand is expected check the DHW Demand/Modulation is selected properly.
Boiler is not responding to call for heat, "Status" shows "Standby" and "Priority" shows Central Heat or Domestic Hot Water.	Boiler is not firing, or temperature is greater than setpoint.	Select display Help icon and review Limit String Status.
Boiler is Running but System or Boiler Circulator is not running.	Pump Not Running.	Check wiring for loose connections or wiring errors. When there is a Domestic Hot Water Heat Request the System or Boiler Pump will be forced "off" when their "Run Pump for" parameter is set to "Central heat, off DHW demand" or "Central Heat, Optional Priority". This has been set to allow all of the heat to be provided for fast indirect water heater recovery. After "Priority protection" time or the end of the Domestic Hot Water Heat Request the system and boiler pumps will be free to run.
Display Completely Dark Fan off, LWCO lights off, no green power light on Control.	No 120 Vac Power at Boiler due to blown high voltage fuse or circuit breaker trip.	Check breaker and wiring between breaker and boiler. Replace blown high voltage fuse. Reset tripped breaker.
Display Completely Dark, Fan running.	No 120 Vac Power at Control; No 24 Vdc to Display.	Check for loose 120 Vac connection wiring between boiler J-Box and transformer or 24 Vdc power supply. Check for loose 24 Vac connection wiring between transformer and Control. Check blown low voltage fuse: Replace if necessary. Check for bad transformer or bad 24 Vdc power supply: Replace if necessary.

INDICATION	POSSIBLE CAUSE	CORRECTIVE ACTION
Blinking Green power light on Control.	Control Fault.	The green light is connected to internal power supply. The power supply is repeatedly starting and stopping (not normal) making the light flash. The microprocessors are not running. Try disconnecting all terminals except 24 Vac to power the control. The green light should be steady. If it is not, then the control is defective. If steady, start plugging in all the connectors while watching the green light. When the faulty wiring reconnected, green light will begin to flash.
Blank Screen with "Reading" shown.	Display lost communication with Control.	Failure to establish Communication upon boot-up once you establish communication, reboot display to read controller and setup display properly.
Communication Error 2	Un-configured control, or control has a memory failure.	The display-write attempt has failed. The controller is un-configured or has a memory failure. Lockout 20 Safety Data Verification will also be displayed. Replace Control.
Communication Error 3	Communication Fault.	Display has lost communication with controller. Check for loose or defective display harness, defective display or defective control. Refer to Concert Boiler Control manual for more details.
Short Cycling	Oversized Boiler	Examine system and boiler operational settings to determine what adjustments may be made to reduce boiler cycling. Contact Manufacturer.
	Incorrect Gas Valve Settings	If combustion is too lean or rich as a result of improper gas valve settings, adjust air-fuel ratio to match factory O <sub>2</sub> settings.
Poor Combustion	Dirty Heat Exchanger	Inspect heat exchanger tubes for damage and carbon build-up. Inspect and clean the burner assembly. Refer to the Service, Maintenance and Inspection section of the manual for guidance.
	Leakage	Remove the boiler's side panels and check for flue gas leakage around the heat exchanger, burner mounting plate, and blower transition piece.

**Appendix A Sizing Gas Piping**

Design the gas piping system to provide an adequate gas supply to the boiler. Refer to Table 6 for minimum and maximum gas supply pressures and boiler capacities. Also consider existing and expected future gas utilizing equipment (i.e., water heater, cooling equipment). Refer to **Error! Reference source not found.** for maximum capacity of schedule 40 pipe. Table 20 lists equivalent pipe length for standard fittings. Given the specific gravity of gas at the boiler's location, a correction factor can be found on Table 21 and multiplied by the "Capacity in Cubic Feet of Gas Per Hour" on **Error! Reference source not found.** For gas piping material other than schedule 40 pipes, refer to the National Fuel Gas Code, NFPA 54/ANSI Z223.1 and/or CAN/CGA B149 Installation codes. Use methods and materials in accordance with Local Codes and requirements of gas supplier. In the absence of such requirement follow National Fuel Gas Codes, NFPA /ANSI Z 223.1 and/or CAN/CGA B149 Installation Codes.

Pipe Length in Equivalent Feet	Pipe Size (npt)							
	¾	1	1-1/4	1-1/2	2	2-1/2	3	4
10	273	514	1060	1580	3050	4860	8580	17500
20	188	353	726	1090	2090	3340	5900	12000
30	151	284	583	873	1680	2680	4740	9660
40	129	243	499	747	1440	2290	4050	8270
50	114	215	442	662	1280	2030	3590	7330
60	104	195	400	600	1160	1840	3260	6640
70	95	179	368	552	1060	1690	3000	6110
80	89	167	343	514	989	1580	2790	5680
90	83	157	322	482	928	1480	2610	5330
100	79	148	304	455	877	1400	2470	5040
125	70	131	269	403	777	1240	2190	4460
150	63	119	244	366	704	1120	1980	4050
175	58	109	224	336	648	1030	1820	3720
200	54	102	209	313	602	960	1700	3460

Based on gas pressures less than 2 psig and a pressure drop of 3.0 iwc and 0.6 specific gravity.



Pipe Size (npt)	ID (in.)	Valves Fully Open (Screwed, Flanged, Welded)				Schedule 40, Screwed Fittings		
		Gate	Globe	Angle	Swing Check	90 deg. Elbow (threaded)	45 deg. Elbow (threaded)	90 deg. Tee, Flow Through Branch (threaded)
1/2	.622	.36	17.3	8.65	4.32	1.55	.73	3.1
3/4	.824	.48	22.9	11.4	5.72	2.06	.96	4.12
1	1.049	.61	29.1	14.6	7.27	2.62	1.22	5.24
1-1/4	1.38	.81	38.3	19.1	9.58	3.45	1.61	6.9
1-1/2	1.61	.94	44.7	22.4	11.2	4.02	1.88	8.04
2	2.067	1.21	57.4	28.7	14.4	5.17	2.41	10.3
2-1/2	2.469	1.44	68.5	34.36	17.1	6.16	2.88	12.3
3	3.068	1.79	85.2	42.6	21.3	7.67	3.58	15.3
4	4.026	2.35	112	56	28	10.1	4.7	20.2
6	6.065	3.54	168	84.1	42.1	15.2	7.07	30.4

Equivalent lengths are for standard screwed fittings and for screwed, flanged, and welded valves relative to schedule 40 steel.

Specific Gravity	Correction Factor	Specific Gravity	Correction Factor
.5	1.1	1.2	.71
.55	1.04	1.3	.68
.6	1.0	1.4	.66
.65	.96	Propane	
.7	.93	1.5	.63
.75	.9	1.6	.61
.8	.87	1.7	.59
.85	.84	1.8	.58
.9	.82	1.9	.56
1.0	.78	Butane	
1.1	.74	2.0	.55

**Appendix B Vent and Combustion Air Pressure Drop Data**

The combined pressure drop through the vent and combustion air duct shall not exceed 100 equivalent feet. Use the tables below to calculate the pressure drop in the vent / combustion air system.

ARC1000 Pressure Drop in Equivalent Feet (Flue Vent)				
Flue Vent Diameter (in.)	Straight Length (eq ft/ft)	90° Elbow (eq ft)	45° Elbow (eq ft)	Velocity (fpm)
6	1	10	5	1534
8	.22	2.22	1.11	863
ARC1500 Pressure Drop in Equivalent Feet (Flue Vent)				
8	.56	5.88	2.86	1296
10	.174	1.75	.87	829
ARC2000 Pressure Drop in Equivalent Feet (Flue Vent)				
8	1	10	5	1728
10	.31	3.125	1.56	1106
12	.12	1.19	.59	768
ARC2500 Pressure Drop in Equivalent Feet (Flue Vent)				
8	1.563	16.67	8.33	2158
10	.478	5	2.44	1381
12	.183	1.852	.92	959
ARC3000 Pressure Drop in Equivalent Feet (Flue Vent)				
8	2.22	25	11.11	2591
10	.68	7.14	3.57	1658
12	.267	2.7	1.35	1152
ARC3500 Pressure Drop in Equivalent Feet (Flue Vent)				
10	.455	4.55	2.727	1935
12	.172	1.724	.862	1344
14	.08	.77	.385	987
ARC4000 Pressure Drop in Equivalent Feet (Flue Vent)				
10	.95	10	4.76	2212
12	.37	3.70	1.85	1536
14	.16	1.64	.81	1129
ARC4500 Pressure Drop in Equivalent Feet (Flue Vent)				
12	.47	4.76	2.33	1729
14	.21	2.08	1.03	1270
16	.10	1.02	.51	972
ARC5000 Pressure Drop in Equivalent Feet (Flue Vent)				
12	.57	5.71	2.85	1920
14	.25	2.56	1.27	1410
16	.13	1.27	.63	1080
ARC5500 Pressure Drop in Equivalent Feet (Flue Vent)				
12	.69	6.90	3.45	2112
14	.31	3.13	1.54	1552
16	.15	1.52	.76	1188
ARC6000 Pressure Drop in Equivalent Feet (Flue Vent)				
12	.83	8.33	4.17	2304
14	.36	3.70	1.85	1693
16	.19	1.82	.91	1296

ARC1000 Pressure Drop in Equivalent Feet (Combustion Air Duct)				
Air Duct Diameter (in.)	Straight Length (eq ft/ft)	90° Elbow (eq ft)	45° Elbow (eq ft)	Velocity (fpm)
6	.6	6.25	3.13	1121
8	.13	1.32	.658	631
ARC1500 Pressure Drop in Equivalent Feet (Combustion Air Duct)				
8	.3	3.03	1.49	946
10	.09	.92	.46	605
ARC2000 Pressure Drop in Equivalent Feet (Combustion Air Duct)				
8	.53	5.26	2.63	1264
10	.164	1.64	.82	809
12	.063	.63	.314	562
ARC2500 Pressure Drop in Equivalent Feet (Combustion Air Duct)				
8	.83	8.3	4.17	1576
10	.26	2.56	1.28	1009
12	.1	.98	.49	701
ARC3000 Pressure Drop in Equivalent Feet (Combustion Air Duct)				
8	1.19	12.5	5.9	1895
10	.37	3.7	1.85	1213
12	.14	1.41	.7	842
ARC3500 Pressure Drop in Equivalent Feet (Combustion Air Duct)				
10	.39	3.92	1.96	1414
12	.15	1.49	.75	982
14	.07	.67	.33	722
ARC4000 Pressure Drop in Equivalent Feet (Combustion Air Duct)				
10	.51	5.13	2.56	1616
12	.20	1.96	.97	1122
14	.087	.87	.44	825
ARC4500 Pressure Drop in Equivalent Feet (Combustion Air Duct)				
12	.25	2.5	1.23	1264
14	.11	1.1	.55	928
16	.054	.55	.27	711
ARC5000 Pressure Drop in Equivalent Feet (Combustion Air Duct)				
12	.31	3.13	1.54	1403
14	.14	1.35	.68	1030
16	.067	.67	.34	789
ARC5500 Pressure Drop in Equivalent Feet (Combustion Air Duct)				
12	.37	3.70	1.85	1544
14	.17	1.64	.82	1134
16	.082	.81	.41	868
ARC6000 Pressure Drop in Equivalent Feet (Combustion Air Duct)				
12	.44	4.55	2.22	1684
14	.20	1.96	.98	1237
16	.097	.97	.49	947

**Appendix C Installation & Startup Report**

Form 2443  
 Revision 0  
 7/17/2017

**Boiler  
 Installation & Startup Report**

Customer: \_\_\_\_\_ Date: \_\_\_\_\_

Address: \_\_\_\_\_ City: \_\_\_\_\_ State: \_\_\_\_\_ Zip: \_\_\_\_\_

Contact: \_\_\_\_\_ Phone: \_\_\_\_\_

=====

Model \_\_\_\_\_ S/N \_\_\_\_\_ Input Rating \_\_\_\_\_

Hydronic  Water Heater  Condensing  Indoor/Outdoor \_\_\_\_\_ Elevation \_\_\_\_\_

Voltage: Supply \_\_\_\_\_ Control: \_\_\_\_\_ Water Temp (SP1) \_\_\_\_\_°F RWT \_\_\_\_\_°F

Ducted Air? \_\_\_\_\_ AL29-4C Vent Material? \_\_\_\_\_ Vent Dia. \_\_\_\_\_ Rain Cap? \_\_\_\_\_

Feet Vertical \_\_\_\_\_ Feet Horizontal \_\_\_\_\_ Elbows/Tees \_\_\_\_\_

Operating Parameter	Setting	
	(static)	(high fire)
Gas Supply Pressure (at inlet to boiler gas train – all units on) (w.c.i. or psi)	High	Low
Fan Speed (rpm)		
Fan Speed, Light-Off (rpm)		
CO (ppm – corrected to 3%O <sub>2</sub> )		
CO <sub>2</sub> (%)		
O <sub>2</sub> (%)		
Stack Temp (°F)		
Room Temp (°F)		
Stack Draft (iwc)		
Combustion Efficiency (%)		
High Gas Pressure Switch Settings (iwc)		
Low Gas Pressure Switch Settings (iwc)		
High Temp Aquastat Setting (°F)		

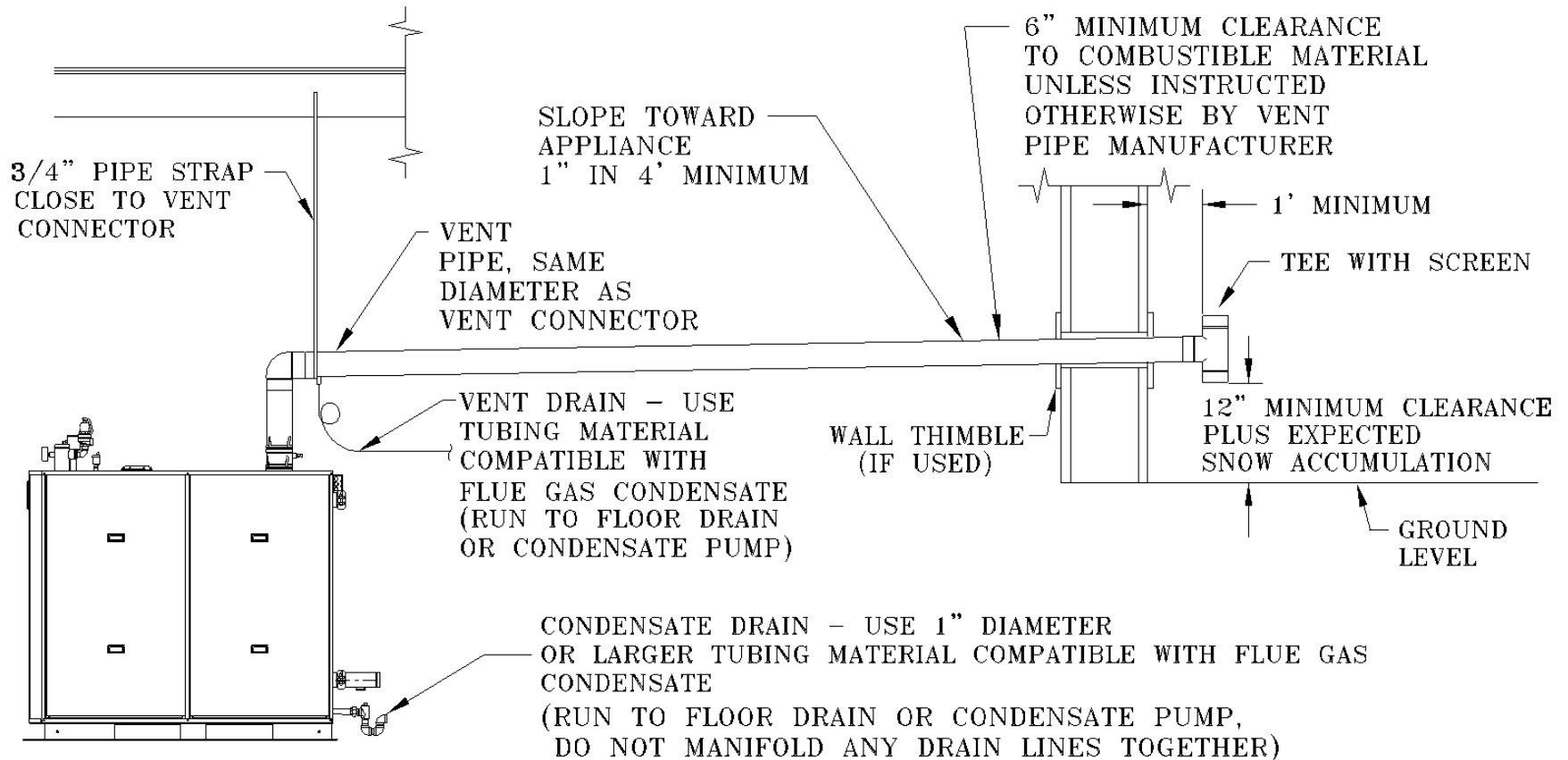
Notes/Comments (use back if necessary): \_\_\_\_\_

\_\_\_\_\_  
 Service Representative / Company

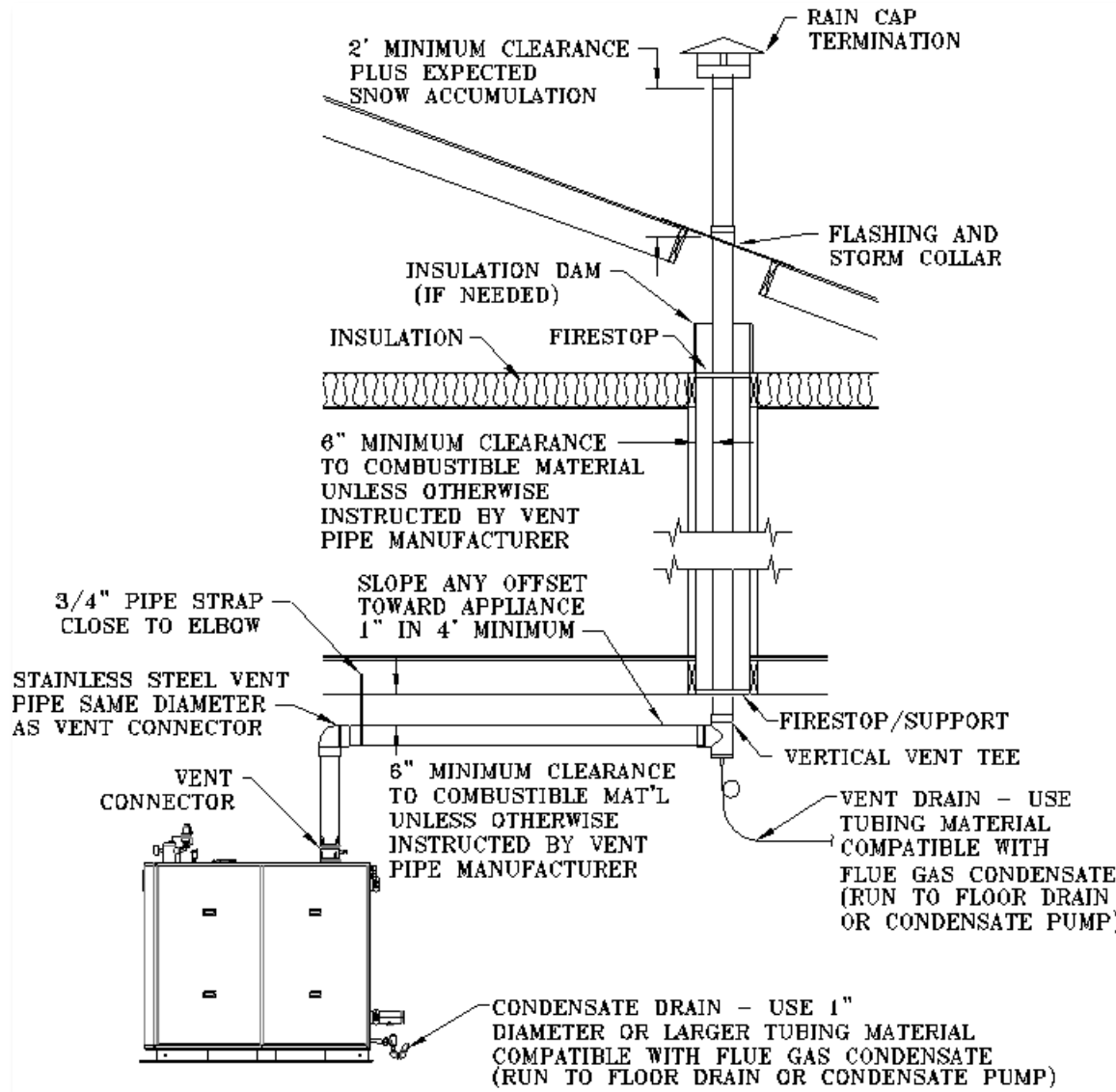
\_\_\_\_\_  
 Customer Representative

## Appendix D Venting Diagrams

### Appendix D.1 Typical Horizontal Vent Piping

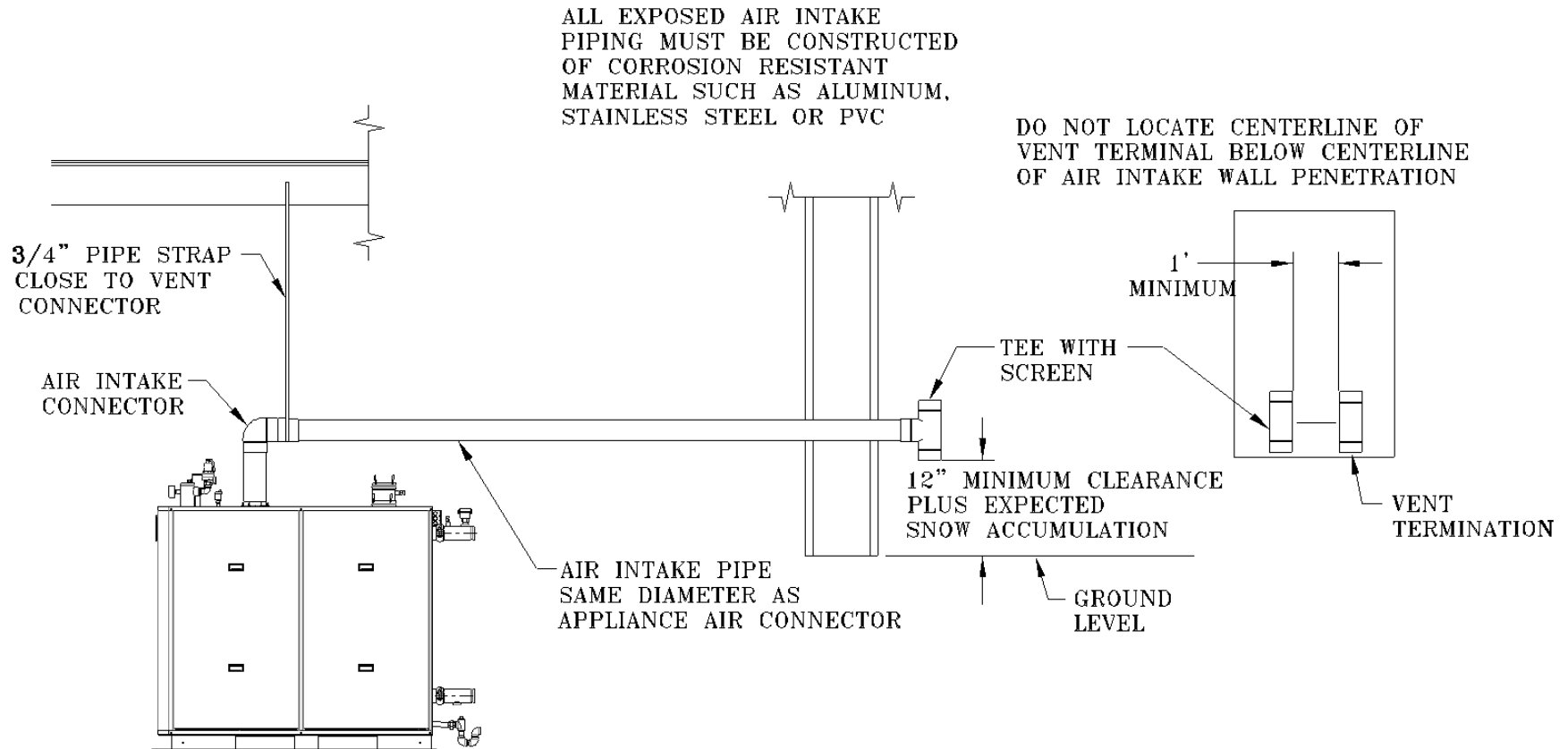


**Appendix D.2 Typical Vertical Pressurized Venting**

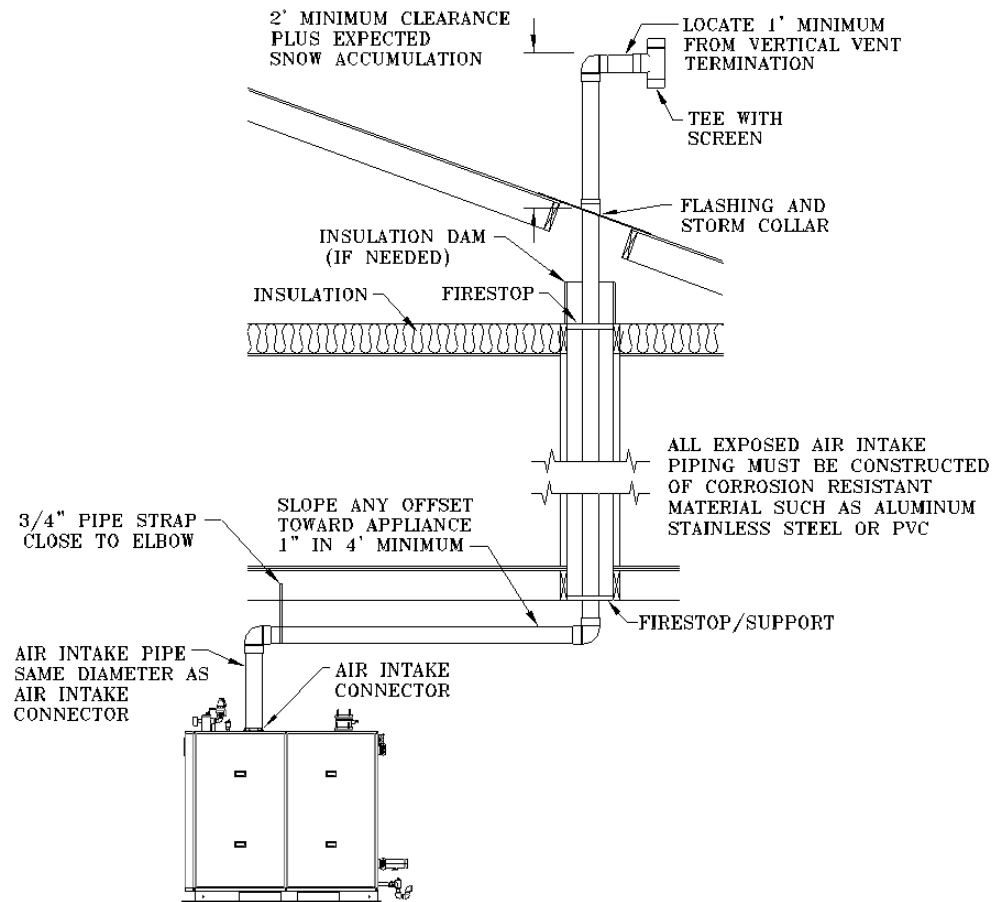


## Appendix E Combustion Air Diagrams

### Appendix E.1 Typical Horizontal Air Intake Piping



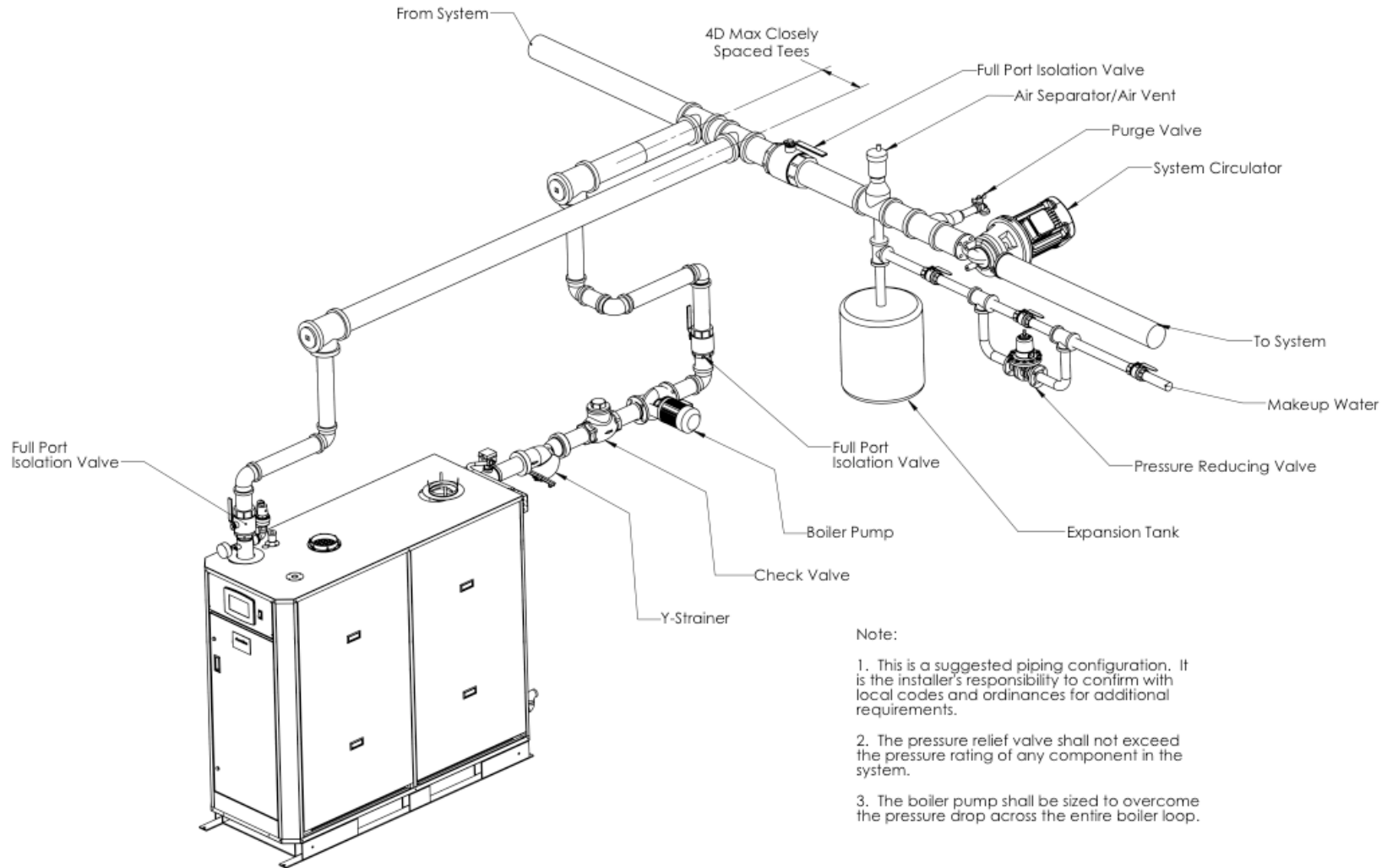
**Appendix E.2 Typical Vertical Air Intake Piping**



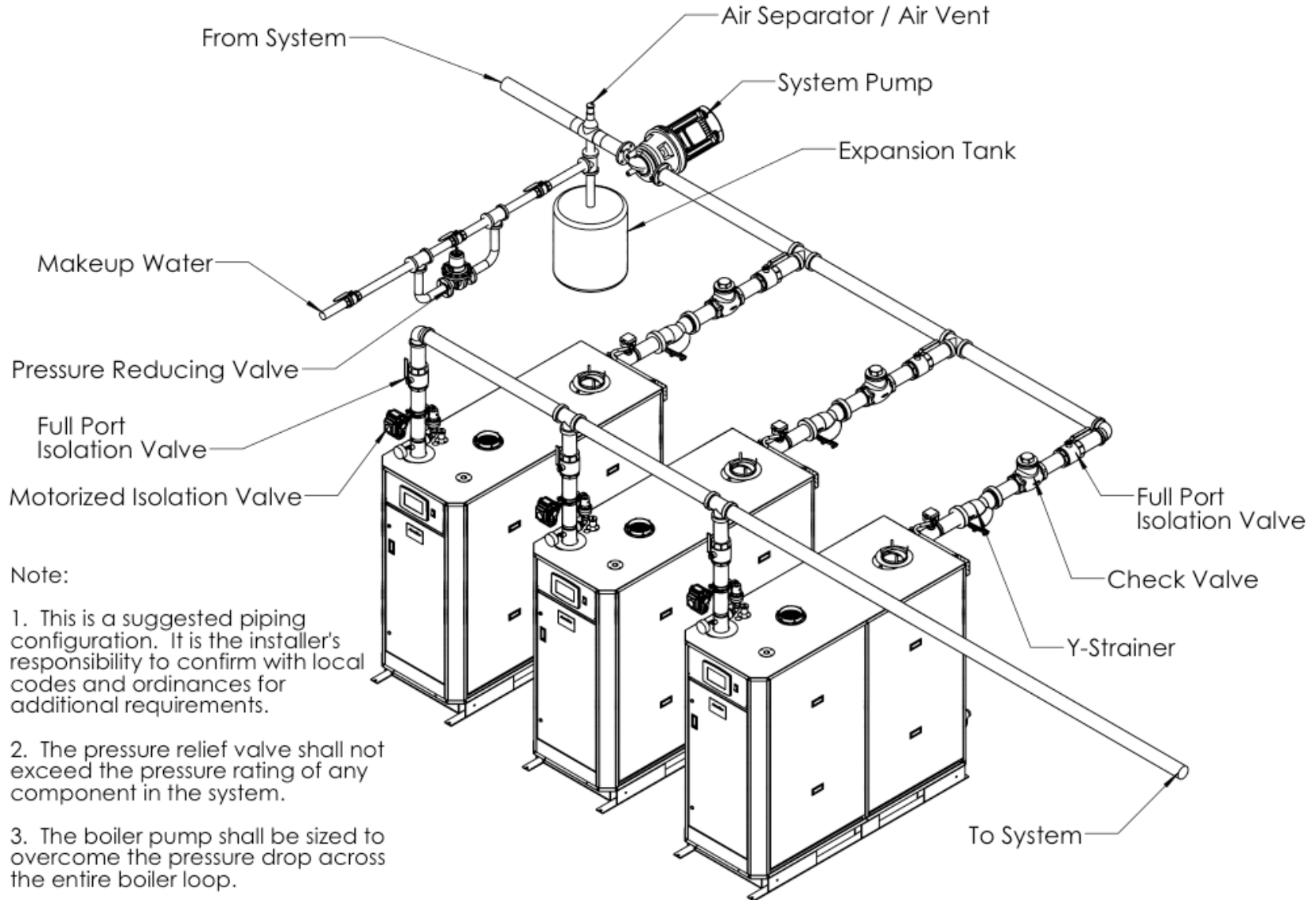


**Appendix F Boiler Piping Diagrams – Typical Layout for all Boiler Models** (Boilers may look different than pictured)

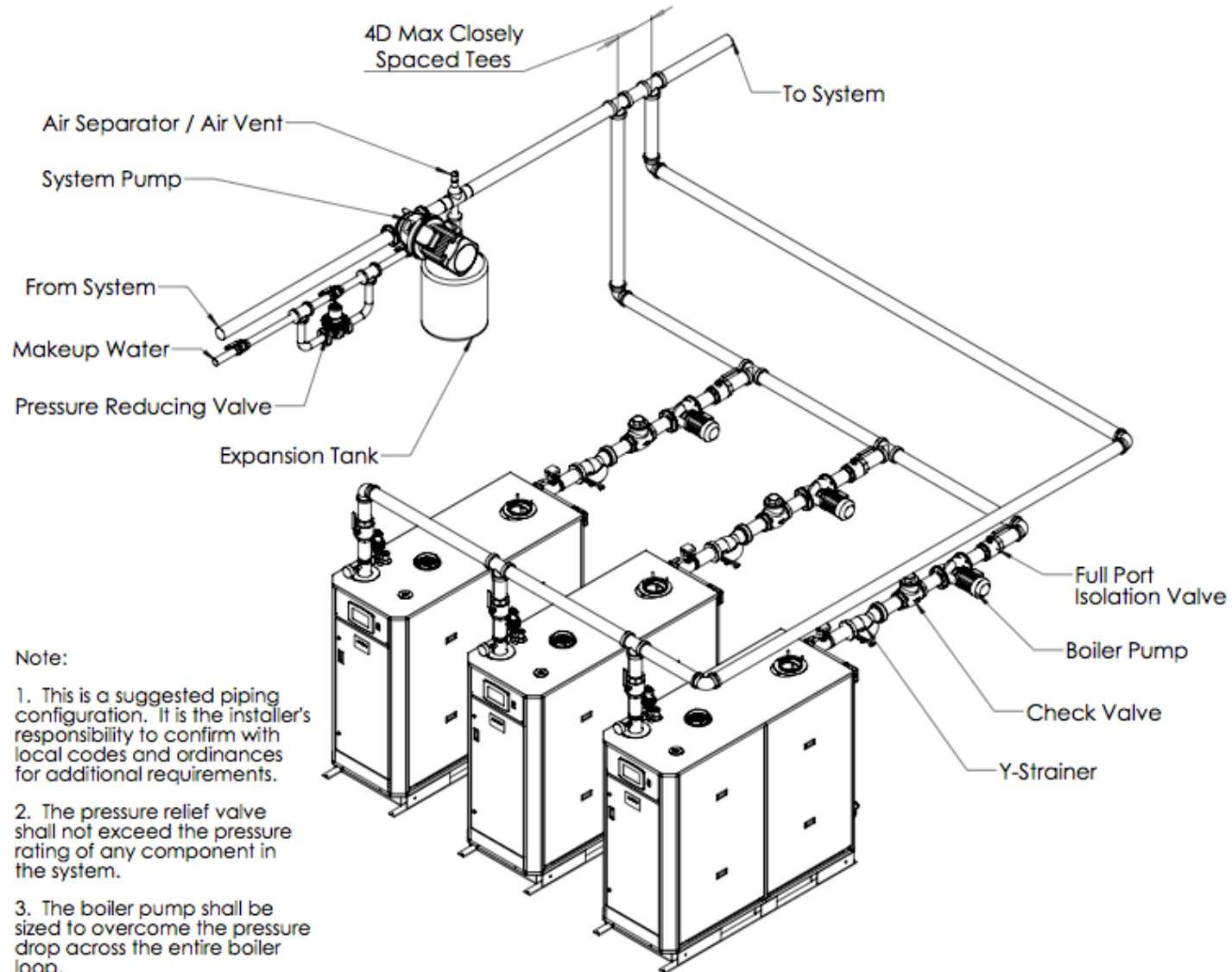
**Appendix F.1 Single Boiler, Primary / Secondary**



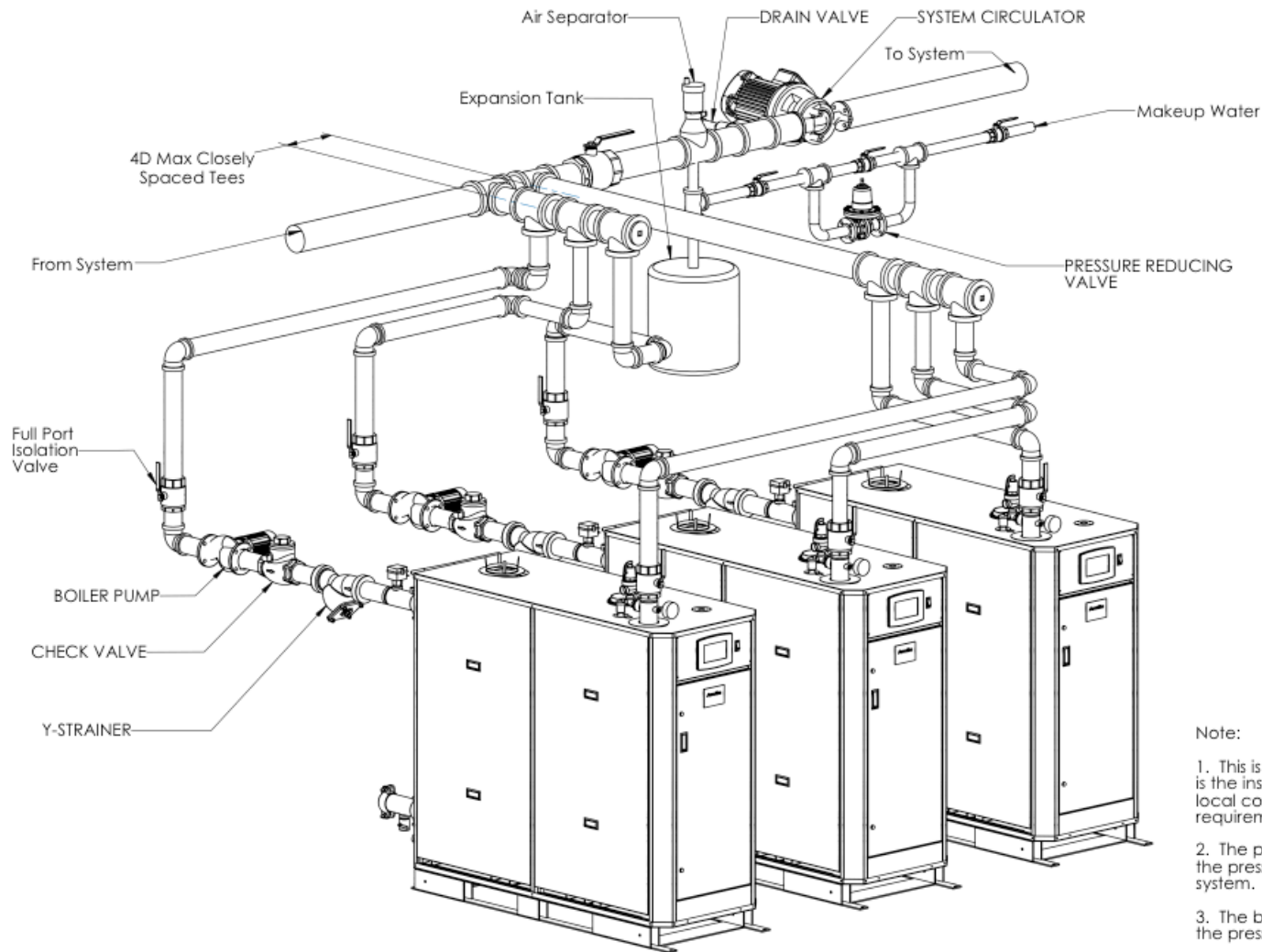
**Appendix F.2 Multiple Boilers, Primary Reverse-Return Piping**



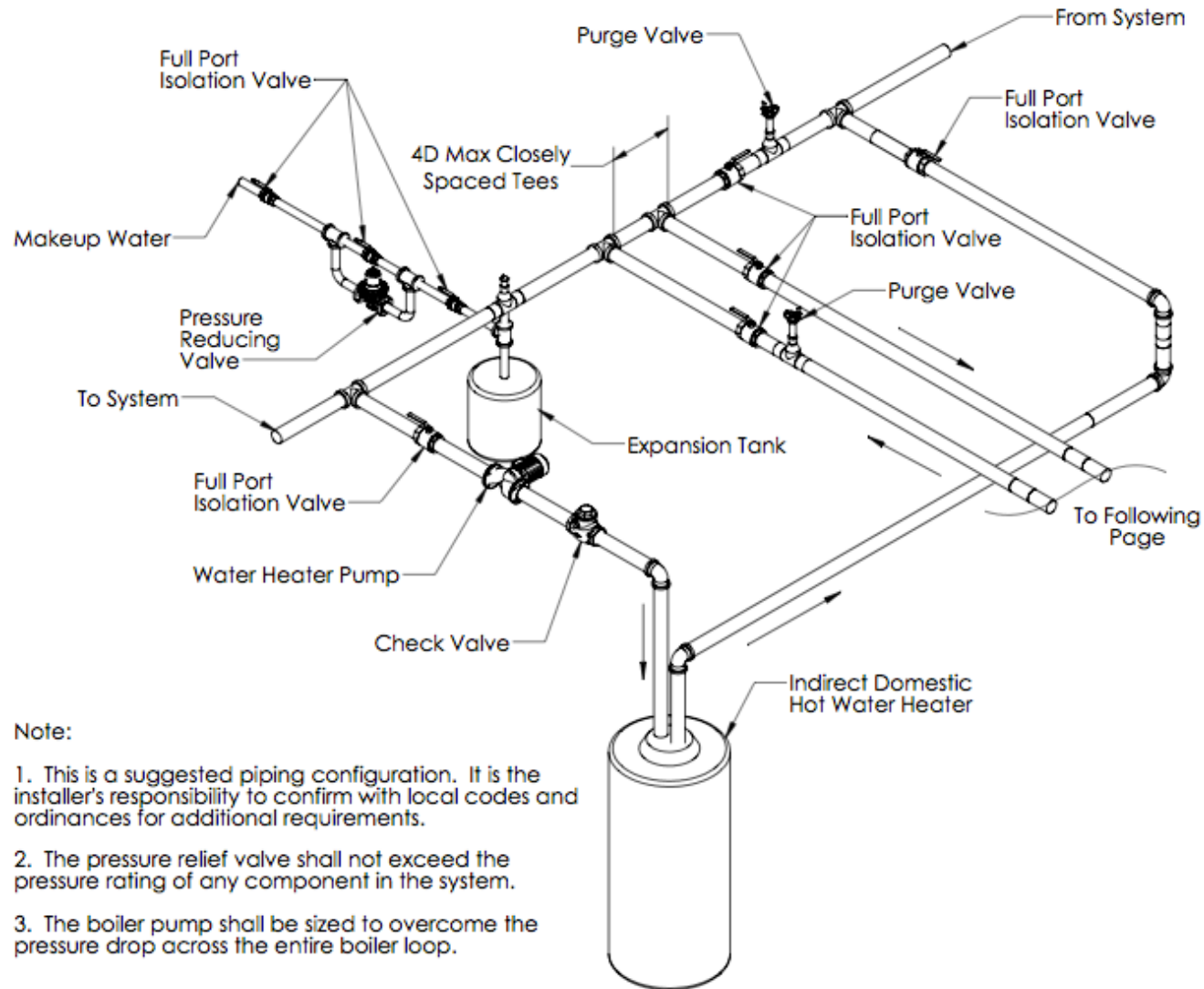
**Appendix F.3 Multiple Boilers, Primary / Secondary Reverse Return Piping**



### Appendix F.4 Multiple Boilers, Primary / Secondary Piping



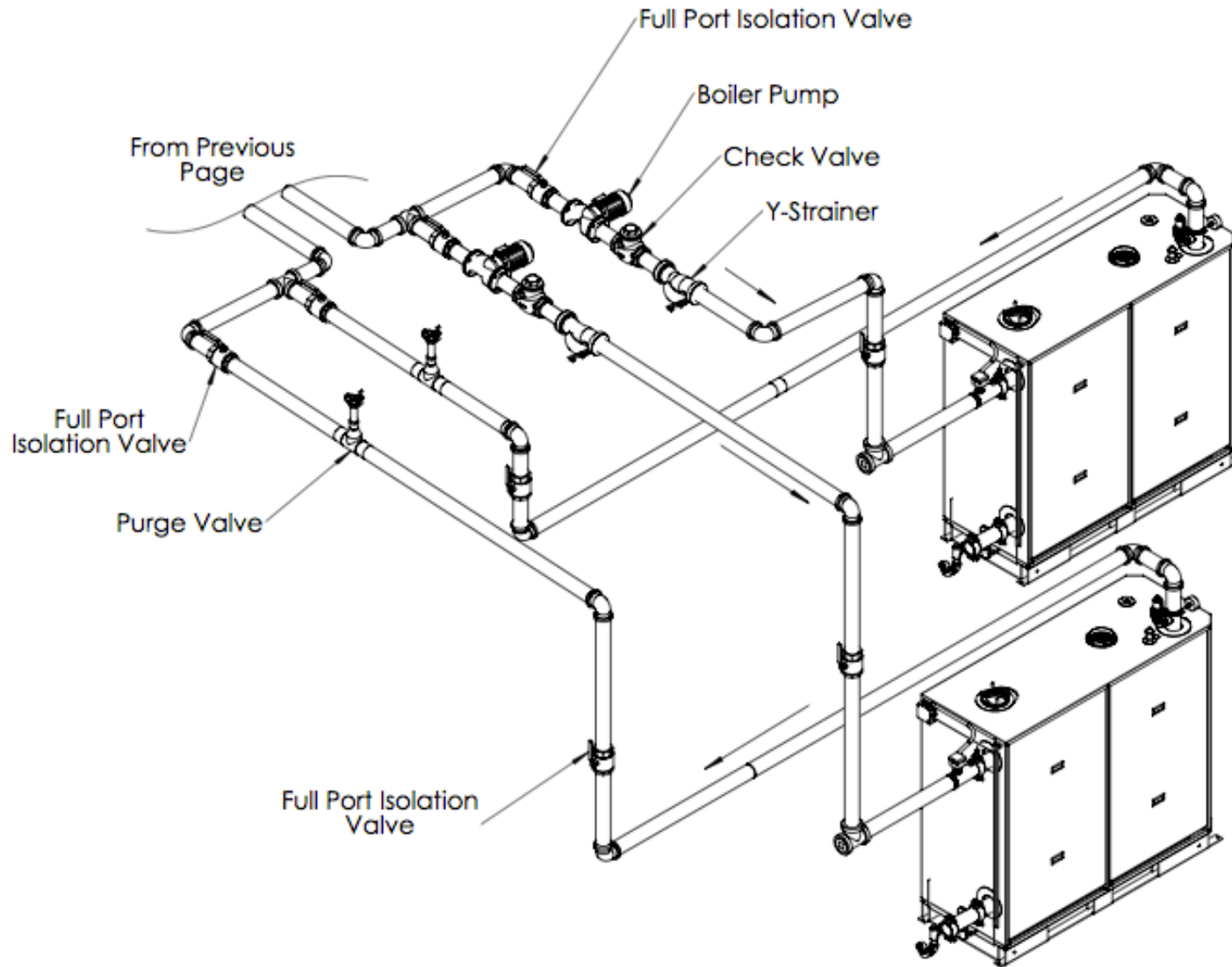
**Appendix F.5 Multiple Boilers, Primary / Secondary Piping, Heating with Domestic Hot Water**



**Note:**

1. This is a suggested piping configuration. It is the installer's responsibility to confirm with local codes and ordinances for additional requirements.
2. The pressure relief valve shall not exceed the pressure rating of any component in the system.
3. The boiler pump shall be sized to overcome the pressure drop across the entire boiler loop.

**Appendix F.6 Multiple Boilers, Primary / Secondary Piping, Heating with Domestic Hot Water (continued)**



**Appendix G Water Flow Pressure Drops**

<b>ARCTIC 1000</b>			<b>ARCTIC 1500</b>			<b>ARCTIC 2000</b>		
<i>Delta T</i>	<i>GPM</i>	<i>Ft. Hd.</i>	<i>Delta T</i>	<i>GPM</i>	<i>Ft. Hd.</i>	<i>Delta T</i>	<i>GPM</i>	<i>Ft. Hd.</i>
100F	19	0.51	100F	29	0.37	100F	38	0.65
90F	21	0.63	90F	32	0.45	90F	42	0.80
80F	24	0.79	80F	36	0.58	80F	48	1.02
70F	27	1.04	70F	41	0.75	70F	54	1.33
60F	32	1.41	60F	48	1.02	60F	63	1.81
50F	38	2.03	50F	57	1.47	50F	76	2.61
45F	42	2.51	45F	63	1.82	45F	84	3.22
40F	48	3.18	40F	71	2.30	40F	95	4.08
35F	54	4.15	35F	81	3.00	35F	109	5.32
30F	63	5.64	30F	95	4.09	30F	127	7.24
25F	76	8.13	25F	114	5.89	25F	152	10.43
20F	95	12.70	20F	143	9.20	20F	190	16.30
<b>ARCTIC 2500</b>			<b>ARCTIC 3000</b>			<b>ARCTIC 3500</b>		
<i>Delta T</i>	<i>GPM</i>	<i>Ft. Hd.</i>	<i>Delta T</i>	<i>GPM</i>	<i>Ft. Hd.</i>	<i>Delta T</i>	<i>GPM</i>	<i>Ft. Hd.</i>
100F	48	0.80	100F	57	1.15	100F	67	.42
90F	53	0.99	90F	63	1.42	90F	74	.50
80F	59	1.25	80F	71	1.79	80F	83	.67
70F	68	1.63	70F	81	2.34	70F	95	.92
60F	79	2.22	60F	95	3.19	60F	111	1.17
50F	95	3.20	50F	114	4.59	50F	133	1.50
45F	106	3.95	45F	127	5.67	45F	148	2.08
40F	119	5.00	40F	143	7.18	40F	166	2.67
35F	136	6.53	35F	163	9.37	35F	190	3.33
30F	158	8.89	30F	190	12.76	30F	222	4.58
25F	190	12.80	25F	228	18.37	25F	266	7.33
20F	238	20.00	20F	285	28.70	20F	333	11.33

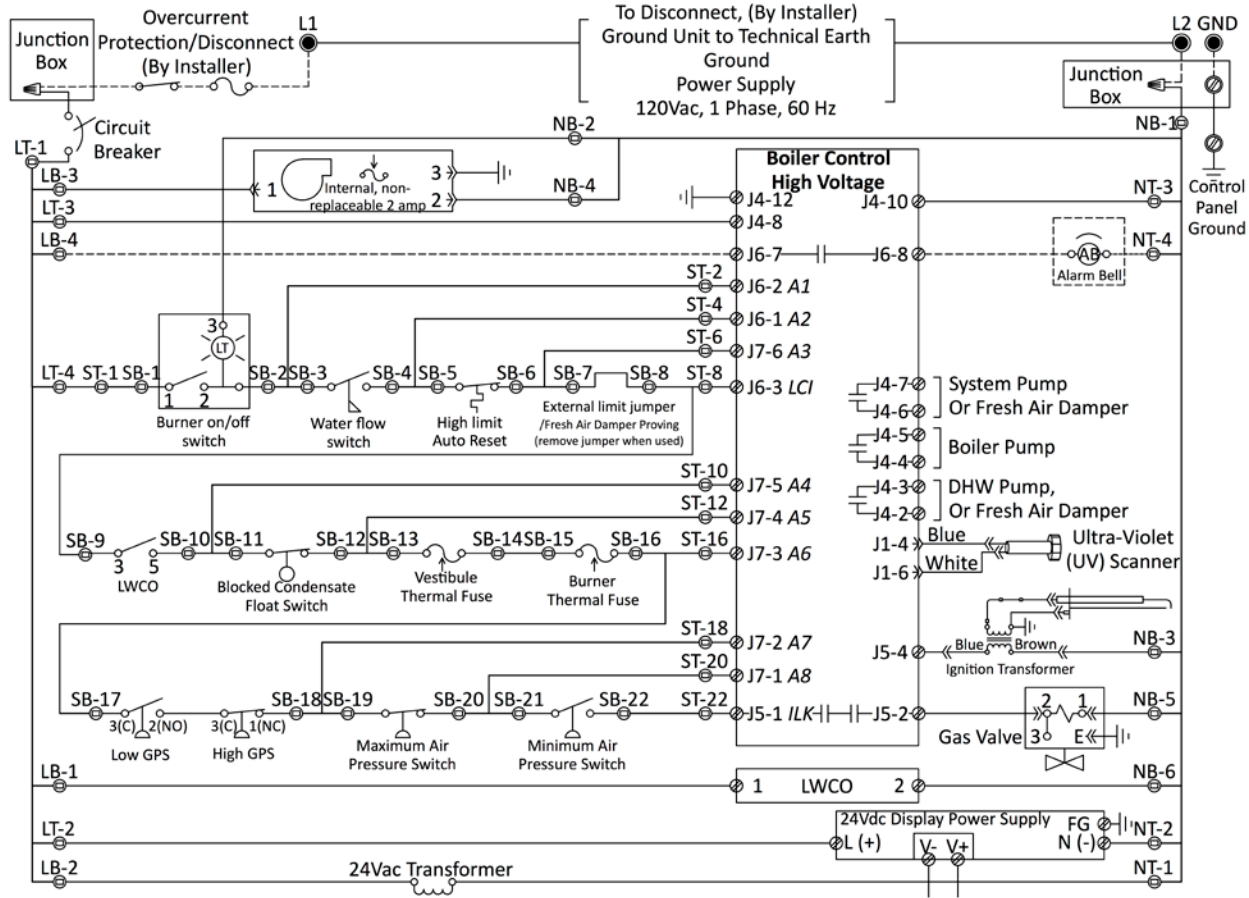
<b>ARCTIC 4000</b>			<b>ARCTIC 4500</b>			<b>ARCTIC 5000</b>		
<i>Delta T</i>	<i>GPM</i>	<i>Ft. Hd.</i>	<i>Delta T</i>	<i>GPM</i>	<i>Ft. Hd.</i>	<i>Delta T</i>	<i>GPM</i>	<i>Ft. Hd.</i>
100F	76	0.42	100F	86	0.42	100F	95	0.50
90F	84	0.58	90F	95	0.50	90F	106	0.58
80F	95	0.92	80F	107	0.58	80F	119	0.67
70F	109	1.17	70F	122	0.67	70F	136	0.83
60F	127	1.42	60F	143	0.92	60F	158	2.08
50F	152	2.42	50F	171	2.92	50F	190	4.17
45F	169	2.58	45F	190	4.17	45F	211	6.25
40F	190	3.17	40F	214	6.25	40F	238	7.92
35F	217	4.42	35F	244	8.17	35F	271	10.42
30F	253	6.08	30F	285	11.17	30F	317	14.25
25F	304	9.67	25F	342	16.08	25F	380	21.42
20F	380	15.17	20F	428	25.17	20F	475	33.50
<b>ARCTIC 5500</b>			<b>ARCTIC 6000</b>					
<i>Delta T</i>	<i>GPM</i>	<i>Ft. Hd.</i>	<i>Delta T</i>	<i>GPM</i>	<i>Ft. Hd.</i>			
100F	105	0.58	100F	114	0.67			
90F	116	0.67	90F	127	0.75			
80F	131	0.92	80F	143	0.92			
70F	149	1.25	70F	163	2.50			
60F	174	2.92	60F	190	4.17			
50F	209	5.83	50F	228	6.00			
45F	232	7.25	45F	253	7.42			
40F	261	9.25	40F	285	9.42			
35F	299	12.08	35F	326	12.33			
30F	348	16.50	30F	380	16.83			
25F	418	23.83	25F	456	24.25			
20F	523	37.25	20F	570	37.92			

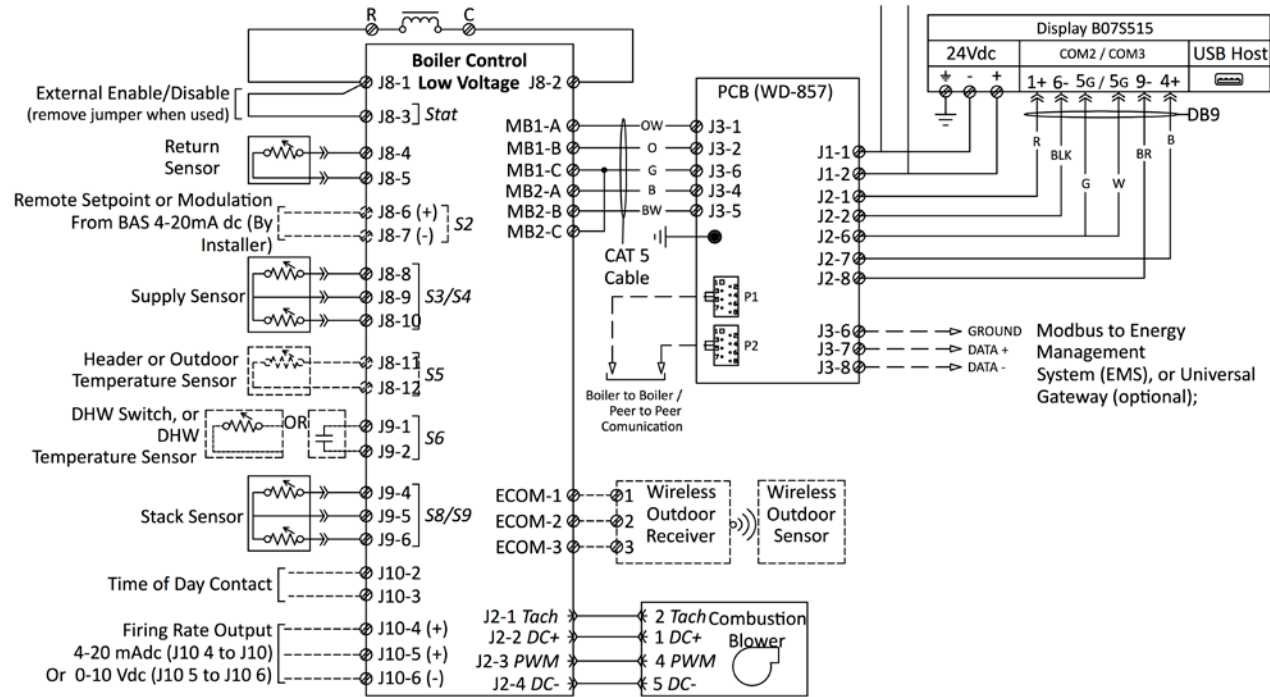
Delta T's are based on the maximum output with a nominal boiler efficiency of 95%.



**Appendix H Wiring Diagrams**

**Appendix H.1 ARC1000 Wiring Diagram**





Modbus to Energy Management System (EMS), or Universal Gateway (optional);

**Terminal Types:**

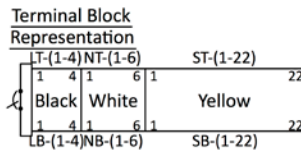
- ⊙ Screw terminal
- » Male/female connector
- ⊕ Terminal block contact
- ⊙ Ground Screw

**Wiring Line Types:**

- Factory standard
- Terminal block conductor
- Field wiring
- ↔ Ignition cable

**Annotations:**

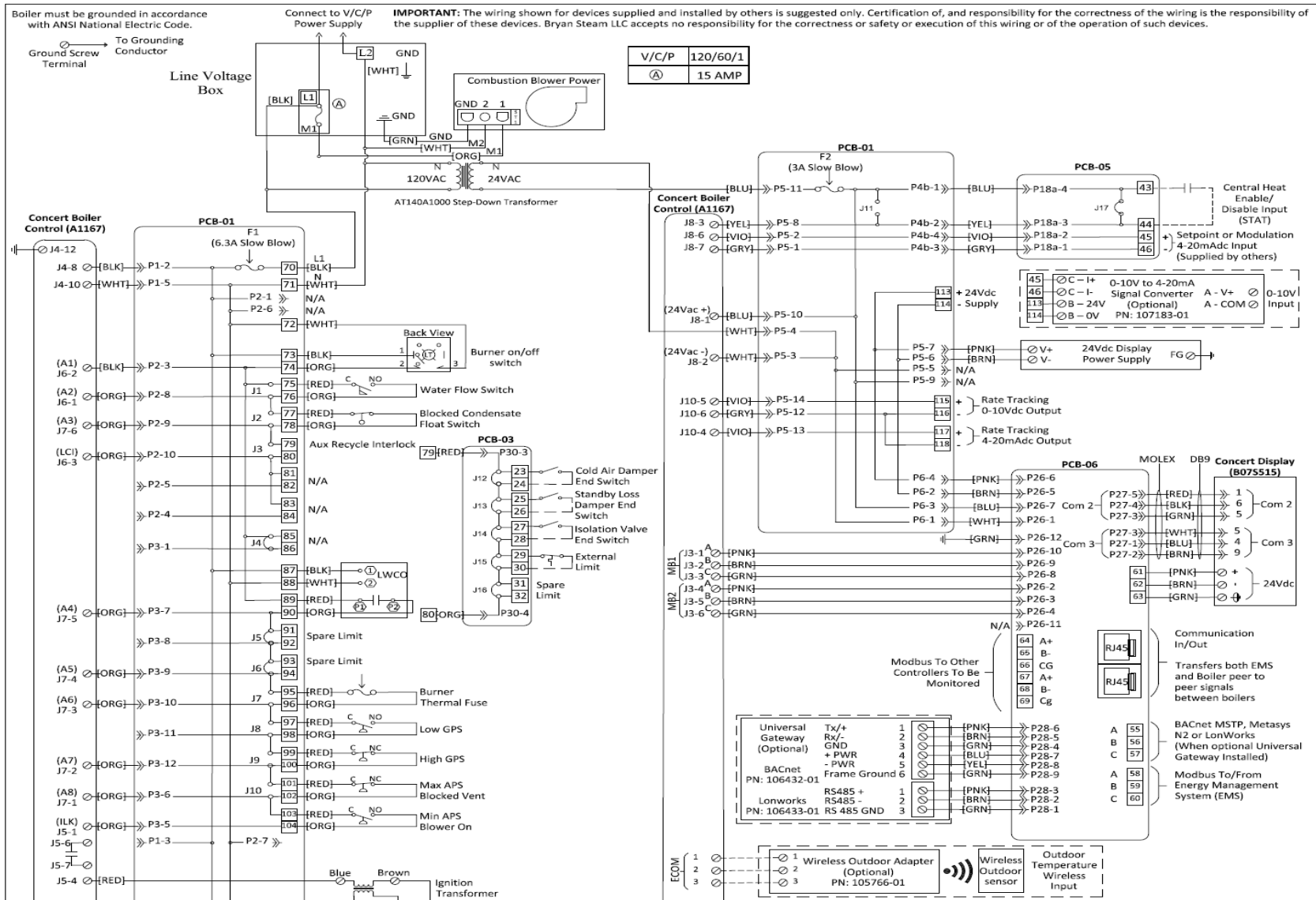
- ⌊ ⌋ Optional Part
- ⌊ ⌋ Field Installed

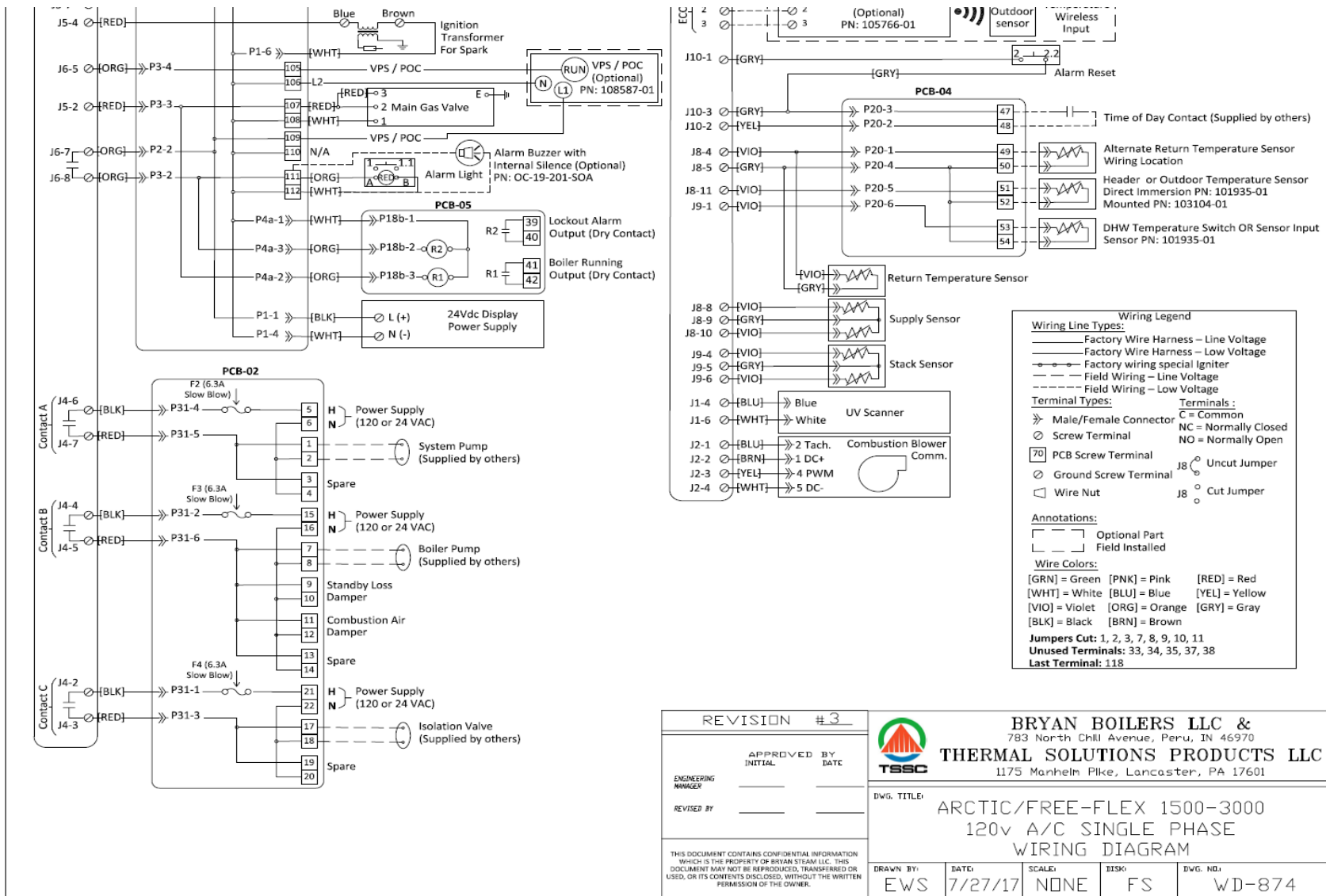


CAT 5 CABLE LEGEND	
DW	= ORANGE/WHITE
O	= ORANGE
GW	= GREEN/WHITE
B	= BLUE
BW	= BLUE/WHITE
G	= GREEN
BRW	= BRDWN/WHITE
BR	= BRDWN
R	= RED
BLK	= BLACK
W	= WHITE

Wiring diagrams are for reference only, please refer to the wiring shipped with the boiler for accuracy.

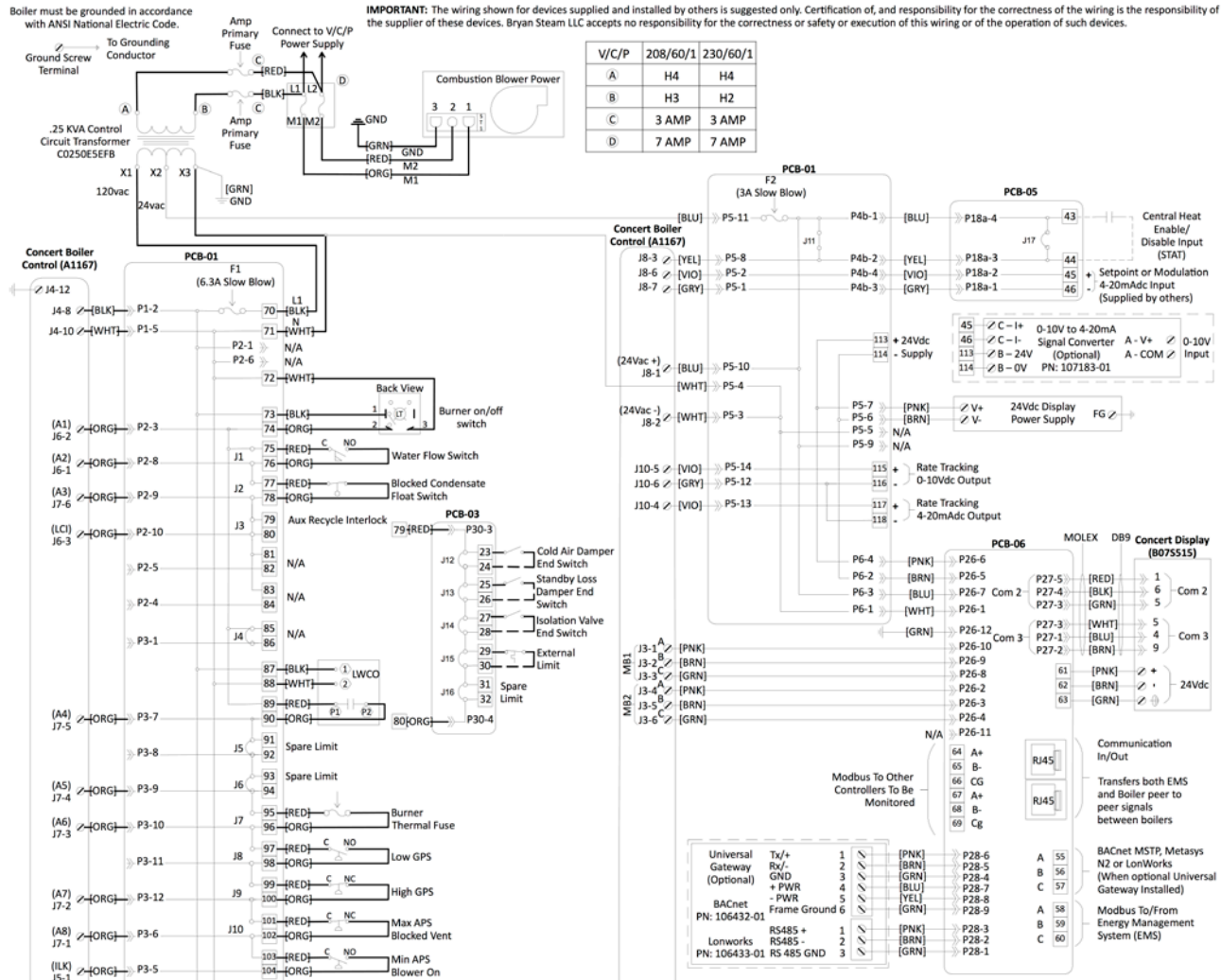
**Appendix H.2 ARC1500 To ARC3000 115 VAC Single Phase Wiring Diagram**

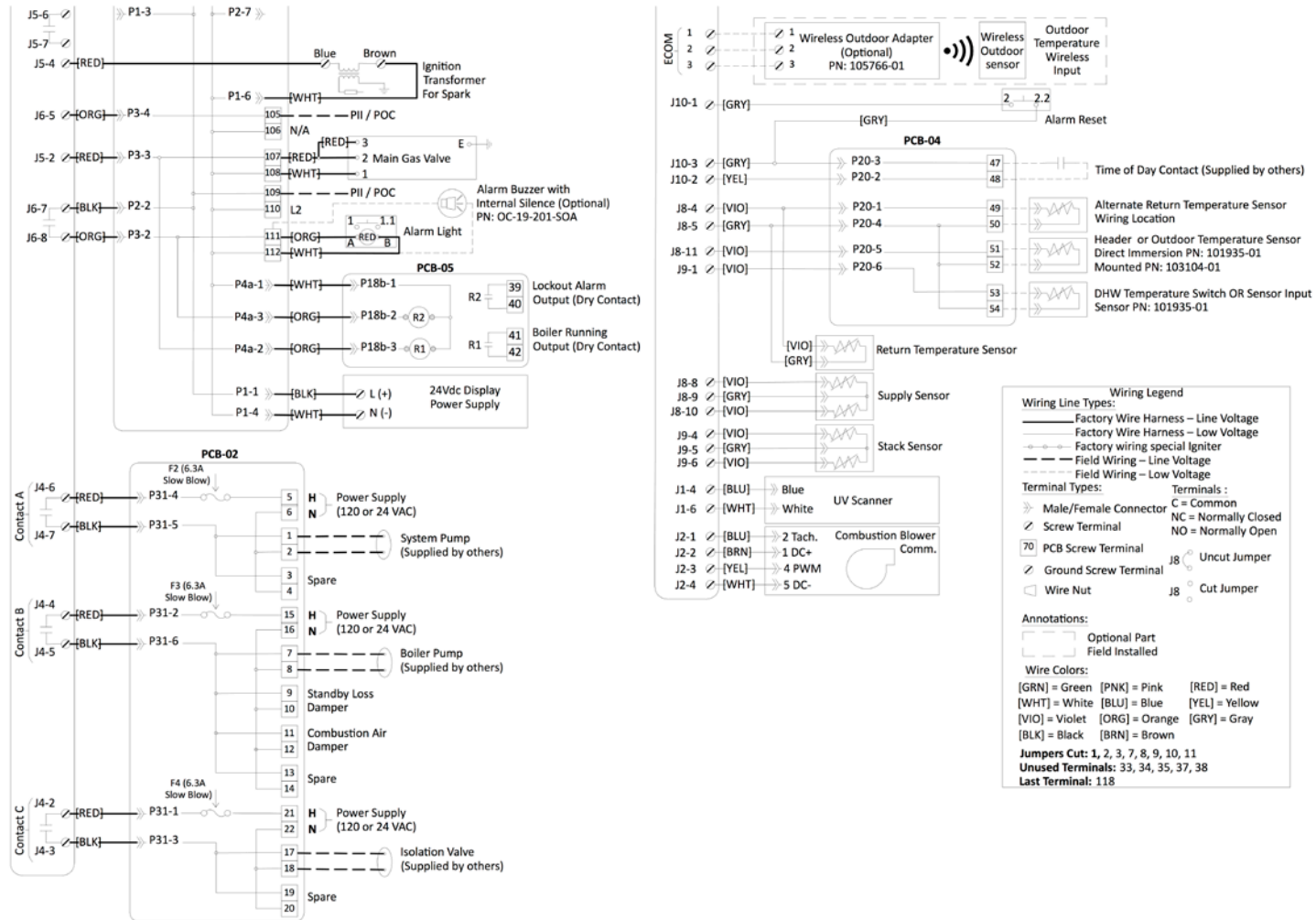




Wiring diagrams are for reference only, please refer to the wiring shipped with the boiler for accuracy

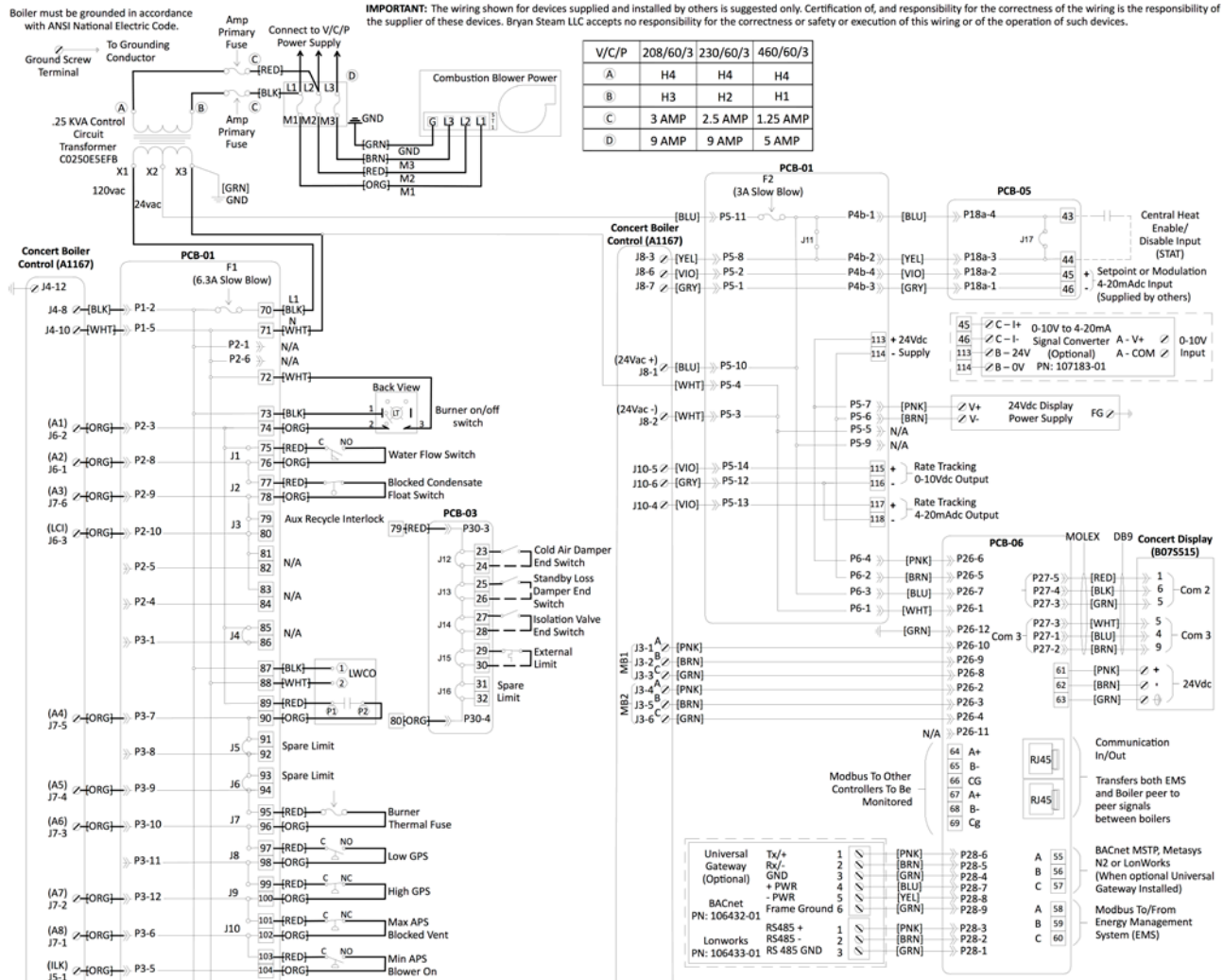
**Appendix H.3 ARC1500 To ARC3000 208 – 230 VAC Single Phase Wiring Diagram**

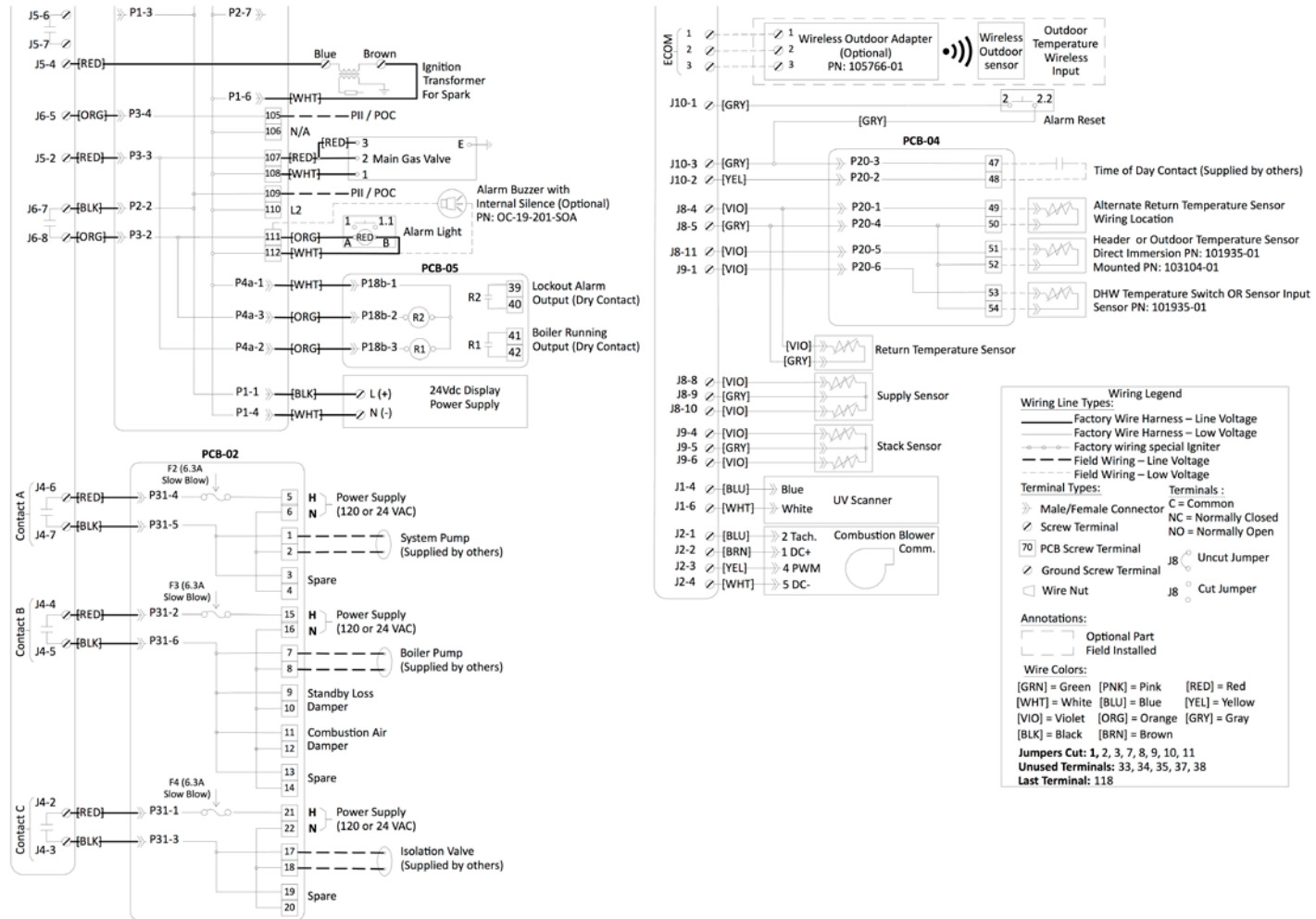




Wiring diagrams are for reference only, please refer to the wiring shipped with the boiler for accuracy.

**Appendix H.4 ARC2000 To ARC3000 208-460 VAC Three Phase Wiring Diagram**

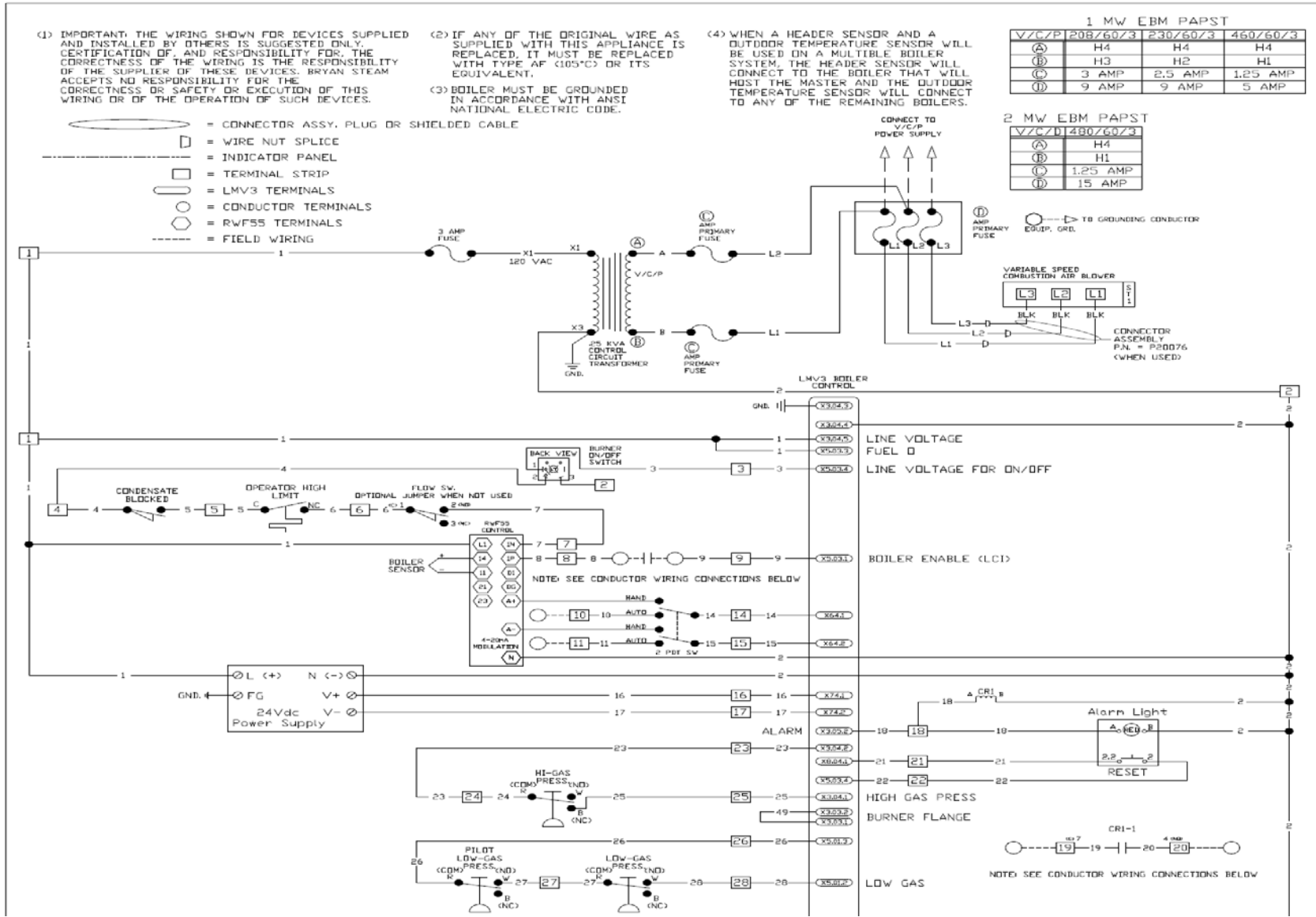


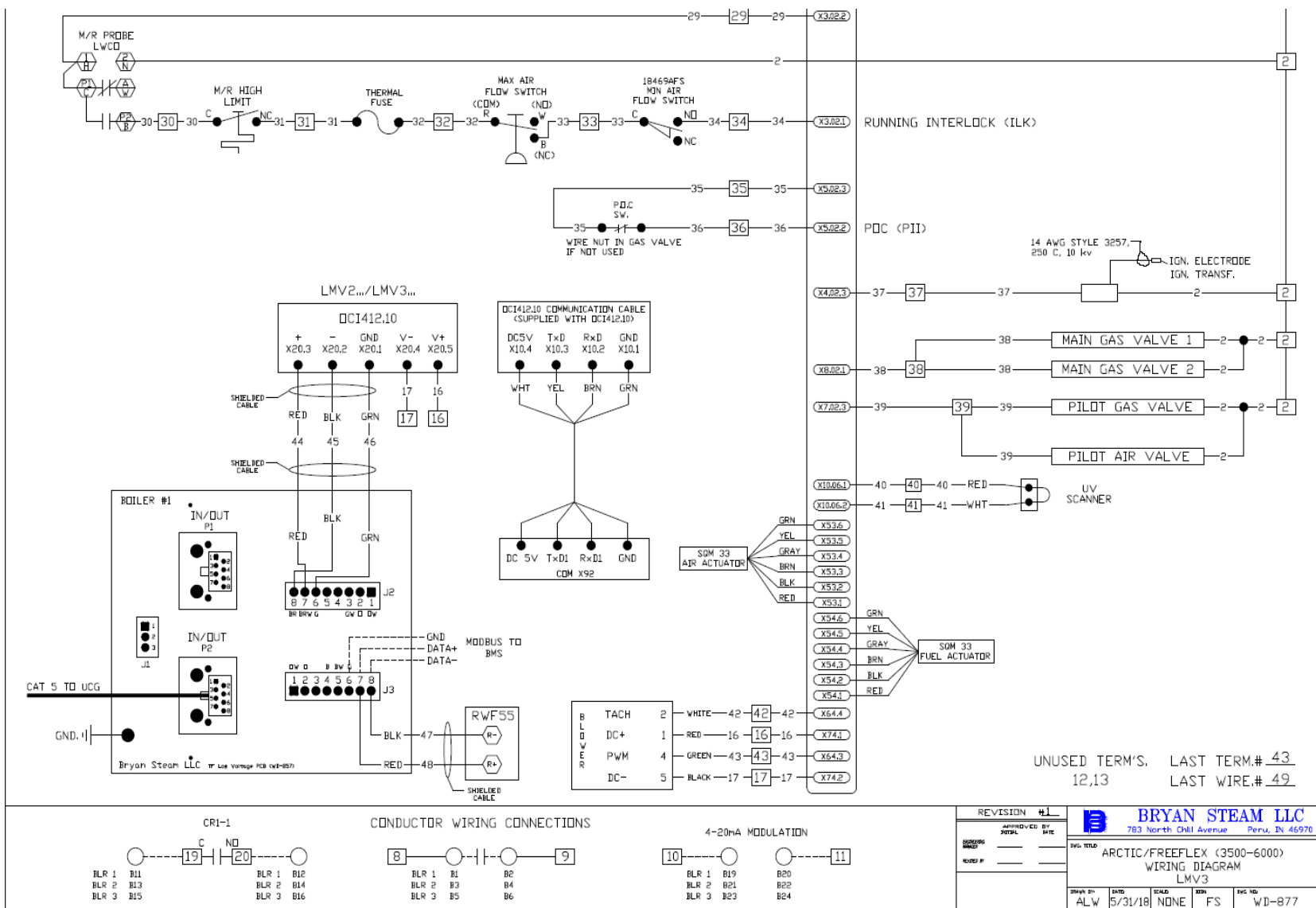


Wiring diagrams are for reference only, please refer to the wiring shipped with the boiler for accuracy.



**Appendix H.5 ARC3500 To ARC6000 208-460 VAC Three Phase Wiring Diagram**





Wiring diagrams are for reference only, please refer to the wiring shipped with the boiler for accuracy.

***Thermal Solutions******("seller")******LIMITED WARRANTY*****LIFETIME THERMAL SHOCK WARRANTY**

Subject to the terms and conditions herein, Seller warrants to the original owner at the original installation site that the boiler pressure vessel is covered against failure due to "Thermal Shock" for the lifetime of the boiler as described below:

- This warranty is only valid if the boiler is installed and operated in accordance with our Installation and Operation Manual.
- This warranty shall cover leaks in pressure vessel (boiler tubes, upper and lower drums) when upon inspection by seller, such damage is attributed to unequal expansion, often described as "thermal shock."
- This warranty does not cover damages or failures that can be attributed to corrosion, scale, dirt or sludge accumulation in the boiler, low water conditions, failure of any safety devices or any other improper service, operation or neglect.

**LIFETIME PRESSURE VESSEL WARRANTY**

Subject to the terms and conditions herein, Seller warrants to the original owner at the original installation site that the boiler pressure vessel is covered against leaks (boiler tubes, upper and lower drums) for the lifetime of the boiler as described below:

- This warranty is only valid if the boiler is installed and operated in accordance with our Installation and Operation Manual.
- This warranty shall cover leaks in pressure vessel (as described above) when upon inspection by seller, such damage is attributed to unequal expansion, often described as "thermal shock."
- This warranty does not cover damages or failures that can be attributed to corrosion, scale, dirt or sludge accumulation in the boiler, low water conditions, failure of any safety devices or any other improper service, operation or neglect.

**FLUE GAS CORROSION WARRANTY**

Subject to the terms and conditions herein, Seller warrants to the original owner at the original installation site that the pressure vessel and flue collector are covered against failure due to fireside flue gas corrosion per the schedule as follows:

- A. Upper and Lower Pressure Vessel Headers - 10 years from date of shipment.
- B. Flexible Boiler Tubes - 5 years from date of shipment.
- C. Flue Collector Sides, Top and Bottom - 5 years from date of shipment.

**BURNER HEAD WARRANTY**

Subject to the terms and conditions herein, Seller warrants to the original owner at the original installation site that the burner head will be free from defects in materials and workmanship for a period of one year after the date of shipment.

**LIMITED WARRANTY**

Subject to the terms and conditions herein, Seller warrants to the original owner at the original installation site those products manufactured by Seller ("Products") comply, at the time of manufacture, with recognized hydronics industry regulatory agency standards and requirements then in effect and will be free from defects in materials and workmanship for a period of one year after the date of shipment.

**REMEDY**

- A. The sole remedy for breach of this warranty is expressly limited to the repair or replacement of any part found to be defective under conditions of normal use within the Warranty Period. Labor for removal and /or installation is not included.
- B. Warranty – The owner must notify the original installer of the Product and Seller (Attention: Thermal Solutions, P.O. Box 3244, Lancaster, PA 17604-3244), in writing, within the Warranty Period, providing a detailed description of all

claimed defects. Transportation to a factory or other designated facility for repairs of any products or items alleged defective shall, in all events, be the responsibility and at the cost of the owner.

#### Exclusions

Seller shall have no liability for and this warranty does not cover:

A. Incidental, special or consequential damages, such as loss of the use of products, facilities or production, inconvenience, loss of time or labor expense involved in repairing or replacing the alleged defective Product.

B. The performance of any Product under conditions varying materially from those under which such Product is usually tested under industry standards as of the time of shipment

C. Any damage to the Product due to abrasion, erosion, corrosion, deterioration, abnormal temperatures or the influence of foreign matter or energy.

D. The design or operation of owner's plant or equipment or of any facility or system of which any Product may be made a part.

E. The suitability of any Product for any particular application.

F. Any failure resulting from misuse, modification not authorized by Seller in writing, improper installation or lack of or improper maintenance.

G. Equipment furnished by the owner, either mounted or un-mounted, or when contracted for by the owner to be installed or handled.

H. Leakage or other malfunction caused by:

1. Defective installations in general and specifically, any installation, which is made:
  - a. In violation of applicable state or local plumbing housing or building codes,
  - b. Without a certified ASME, pressure relief valve, or
  - c. Contrary to the written instructions furnished with the unit.
2. Adverse local conditions in general and, specifically, sediment or lime precipitation in the tubes and/or headers or corrosive elements in the atmosphere.

3. Misuse in general and, specifically, operation and maintenance contrary to the written instructions furnished with the unit, disconnection, alteration or addition of components or apparatus, not approved by Seller, operation with fuels or settings other than those set forth on the rating plate or accidental or exterior damage.

I. Production of noise, orders, discoloration or rusty water.

J. Damage to surrounding area or property caused by leakage or malfunction.

K. Costs associated with the replacement and/or repair of the unit including: any freight, shipping or delivery charges, and removal, installation or reinstallation charges, any material and/or permits required for installation, reinstallation or repair, charges to return the boiler and or components.

Seller's liability under this warranty shall not in any case exceed the amount paid for the Product found to be defective.

#### Third-Party Warranties

For goods or components not manufactured by Seller, the warranty obligations of Seller shall, in all respects, conform and be limited to one year from the date of shipment.

#### Severability

To the extent that any provisions shall of this warranty would be void or prohibited under applicable law, such provisions shall be limited in effect to the minimum extent necessary to render the remaining provisions hereof enforceable.