

ARCTIC

High Efficiency, Low Emission CONDENSING BOILER

INSTALLATION & OPERATION MANUAL

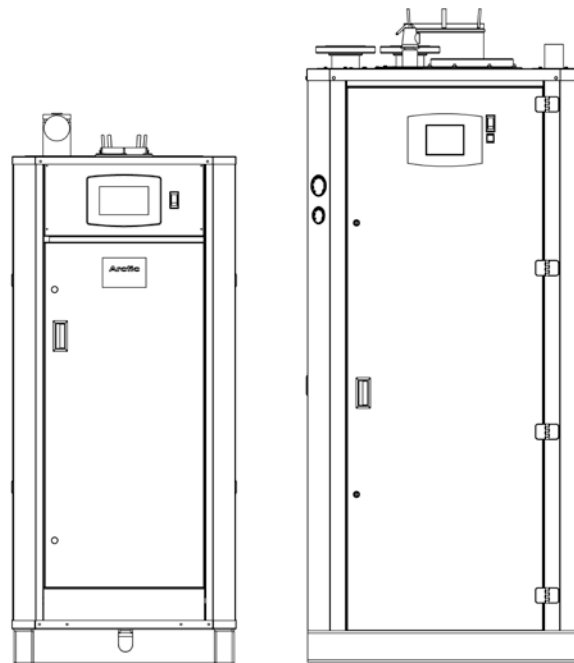

For service and repair to the boiler, call your heating contractor. When seeking information on the boiler from the manufacturer, provide boiler model and serial number as shown on the rating label.

Boiler Model:	Serial Number:
Installation Date:	Type System:
Heating Contractor:	Phone/Email:
Address:	



This manual must only be used by a qualified heating installer/service technician. Read all instructions in this manual before installing. Perform steps in the order given. Failure to comply could result in severe personal injury, death, or substantial property damage.



Table of Contents

1	Introduction.....	6
1.1	Important Information	6
1.2	Disclaimers and Local Codes	6
1.3	Test and Inspections.....	7
1.4	Component Description	8
2	Pre-Installation.....	9
2.1	Installation Conformance	9
2.2	Boiler Foundation	9
2.3	Clearances and Serviceability	9
3	Installation	11
3.1	Receiving The Boiler	11
3.2	Boiler Connections	11
3.2.1	Flow Connection.....	11
3.2.2	Safety Relief Valves.....	11
3.2.3	Expansion Tank Connections	11
3.2.4	Drain Connection.....	11
3.2.5	Condensate Drain Connection	11
3.2.5.1	ARC1000 Condensate Drain Trap.....	12
3.2.5.2	ARC1500 – 3000 Condensate Drain Trap	12
3.2.6	Gas Supply Connection.....	13
3.2.6.1	Drip Leg	13
3.2.6.2	Gas Piping Leak Test	13
3.2.6.3	Venting of Gas Train Components.....	13
3.3	Combustion Air Supply System.....	13
3.3.1	Combustion Air Openings:.....	14
3.3.1.1	Two Permanent Opening Method.....	14
3.3.1.2	One Permanent Opening Method	14
3.3.1.3	Mechanical Air Supply Systems.....	14
3.3.2	Louvers, Grilles, and Screens.....	15
3.3.2.1	Louvers and Grilles:.....	15
3.3.2.2	Screens.....	15
3.3.2.3	Motorized Louvers:.....	15
3.3.2.4	Combustion Air Ducts.....	15
3.3.3	Ducted Combustion Air.....	16
3.4	Venting Requirements	16
3.4.1	Massachusetts.....	17
3.4.2	Combustion Air and Venting Requirements for Canada.....	19
3.4.2.1	Air Supply Requirements per CAN/CSA-B149.1-05 for Appliances having an input exceeding 400 MBH.....	19
3.4.2.2	Combustion Air Supply Dampers, Louvers, and Grilles.....	20
3.4.2.3	Mechanical Combustion Air Supply	20
3.4.2.4	Appliance Venting per CAN/CSA-B149.1-05	20
3.5	Requirements	20
3.5.1	Electrical	20
3.5.2	Gas Supply Requirements.....	21
3.5.3	Sound Pressure Levels	21
3.5.4	Pump and Piping Requirements	22
3.5.4.1	Water Flow Rates (Variable Primary Pumping Systems).....	22
3.5.4.2	Water Flow Rates (Primary / Secondary Systems).....	23

3.5.4.3	Water Flow Rates (Constant Volume Primary Pumping Systems).....	23
3.5.4.4	Water Flow Rates for Glycol	23
3.6	Before Placing Boiler In Operation.....	23
3.6.1	Pre-Boil Out Flushing Of System.....	23
3.6.2	Boil Out Procedure	24
3.6.3	Replacement Boiler Installations.....	24
3.7	Draining and refilling the boiler & system	25
3.7.1	Filling The System.....	25
3.7.2	Hydrostatic Test Of Boilers And System.....	25
3.8	Boiler Water Treatment.....	25
3.8.1	Purpose of water treatment.....	25
3.8.2	Objectives	26
3.8.3	Water softener.....	26
3.8.4	Continuous Monitoring.....	26
4	SYSTEM START-UP	28
4.1	Concert Boiler Control Display Navigation	28
4.2	System Check:.....	28
4.3	Power the Boiler:	28
4.4	Power the Circulators:	28
4.5	Pressurize the Fuel System:.....	28
4.6	Select Operational Mode:.....	29
4.7	Begin Commissioning the Boiler:	29
4.8	Finish Commissioning the Boiler:	30
4.9	Re-Starting After Prolonged Shutdown	30
4.10	Testing of Controls and Safety Devices.....	31
4.11	Ignition Failure	31
5	Service, Maintenance, and Inspection.....	32
5.1	General Maintenance:.....	32
5.1.1	DAILY:	32
5.1.2	WEEKLY:	33
5.1.3	MONTHLY:	33
5.1.4	ANNUALLY:.....	33
5.2	Ignition Assembly Cleaning	33
5.3	Burner Assembly Cleaning.....	34
5.4	Heat Exchanger Cleaning	34
5.5	Tube Replacement Procedure	35
5.6	Safety and Operating Controls.....	38
5.7	Troubleshooting	39
Appendix A	Sizing Gas Piping.....	42
Appendix B	Vent and Combustion Air Pressure Drop Data.....	45
Appendix C	Venting Diagrams.....	47
Appendix C.1	Typical Horizontal Vent Piping	47
Appendix C.2	Typical Vertical Pressurized Venting	48
Appendix D	Combustion Air Diagrams.....	49
Appendix D.1	Typical Horizontal Air Intake Piping.....	49
Appendix D.2	Typical Vertical Air Intake Piping.....	50
Appendix E	Boiler Piping Diagrams.....	51
Appendix E.1	Single Boiler, Primary / Secondary	51
Appendix E.2	Multiple Boilers, Primary Reverse-Return Piping.....	52
Appendix E.3	Multiple Boilers, Primary / Secondary Reverse Return Piping	53

Appendix E.4 Multiple Boilers, Primary / Secondary Piping..... 54

Appendix E.5 Multiple Boilers, Primary / Secondary Piping, Heating with Domestic Hot Water... 55

Appendix E.6 Multiple Boilers, Primary / Secondary Piping, Heating with Domestic Hot Water
(continued) 56

Appendix F Water Flow Pressure Drops..... 57

Appendix G Wiring Diagrams 58

Appendix G.1 ARC1000 Wiring Diagram..... 58

Appendix H Repair Parts 60

Appendix H.1 ARC1000 Heat Exchanger..... 60

Appendix H.2 ARC1000 Burner Assembly..... 62

Appendix H.3 Gas Train and Upper Vestibule Controls 63

Appendix H.4 Jacket..... 65

Appendix H.5 Outlet Manifold..... 67

Appendix H.6 Miscellaneous External Components..... 69

Appendix H.7 Controls 71

Tables

Table 1: Clearances and Serviceability 10

Table 2: Typical Condensate Flow Rate 12

Table 3: Electrical Requirements 21

Table 4: Gas Supply Requirements 21

Table 5 Sound Pressure Levels 21

Table 6 Minimum Water Flow Rates for Variable Primary Pumping..... 22

Table 7 Maximum Water Flow Rates for Variable Primary Pumping..... 22

Table 8 Water Flow Rates for Primary / Secondary Pumping 20F ΔT 23

Table 9 Water Flow Rates for Primary / Secondary Pumping 40F ΔT 23

Table 10: Water Flow Rates for Constant Volume Primary Pumping..... 23

Table 11 GPM Increase for Glycol Systems..... 23

Table 12: Chemical Agents and Effects..... 26

Table 13 Recommended Feed Water Limits 27

Table 14: Safety Device Test..... 31

Table 15: Safety and Operating Controls 38

Table 16: General Troubleshooting 39

Table 17: Maximum Gas Capacity Of Schedule 40 Pipe 43

Table 18: Equivalent Lengths Of Standard Pipe Fittings And Valves..... 43

Table 19: Specific Gravity Correction Factors 44

Table 20: Heat Exchanger Parts 61

Table 21: Burner Assembly 62

Table 22: Gas Train and Upper Vestibule Controls 64

Table 23: Jacket..... 66

Table 24: Outlet Manifold 68

Table 25: Miscellaneous External Components 70

Table 26: Controls 72

Figures

Figure 1: ARC1000 External Boiler Connections and Components 8

Figure 2: ARC1500 - 3000 External Boiler Connections and Components 8
Figure 3: Clearances and Serviceability 10
Figure 4: ARC 1000 Condensate Drain Trap 12
Figure 5: ARC1500 - 3000 Condensate Drain Trap 13
Figure 6: High and Low Fire Adjustments on the Main Gas Valve Regulator 29
Figure 7: Ignition Assembly 34
Figure 8: Panel Removal in Preparation for Tube Inspection 35
Figure 9: Tube Puller Insertion..... 36

1 Introduction

1.1 Important Information

The following terms are used throughout this manual to bring attention to the presence of hazards of various risk levels, or to important information concerning product life. It is critical that all personnel read and follow all the information provided in the boxes marked DANGER, WARNING, CAUTION, and NOTICE.

DANGER

Indicates an imminently hazardous situation, which, if not avoided, will result in death, serious injury or substantial property damage.

WARNING

Indicates a potentially hazardous situation, which, if not avoided, could result in death, serious injury or substantial property damage.

CAUTION

Indicates a potentially hazardous situation, which, if not avoided, may result in moderate or minor injury or property damage.

NOTICE

Indicates specific instructions on installation, operation, or maintenance, which are important but not related to personal injury hazards.

1.2 Disclaimers and Local Codes

Installation must conform to the requirements of the authority having jurisdiction. In the absence of such requirements, installation must conform to the *National Fuel Gas Code, NFPA 54/ANSI Z223.1*, and/ or *CAN/CGA B149 Installation Codes*. Where required by the authority having jurisdiction, the installation must conform to the *Standard for Controls and Safety Devices for Automatically Fired Boilers, ANSI/ ASME CSD-1*.

Installation, start-up, and maintenance of this equipment can be hazardous and requires trained, qualified installers and service personnel. Do not install, operate, service or repair any components of this equipment unless you are qualified and fully understand all requirements and procedures. Trained personnel refer to those who have completed Thermal Solutions Service School training specific to this product.

The boiler heat exchanger is manufactured and stamped in accordance with ASME Boiler and Pressure Vessel Code, Section IV for a maximum allowable working pressure and operating temperature of 160 psig (1103 kPa) and 210 F(99 C) respectively. Aqua-stat is factory set at 200 F (93 C).

NOTICE

Post these instructions and maintain in legible condition.

1.3 Test and Inspections

Upon the completion of boiler installation, final air-fuel adjustments are to be made by factory trained service personnel. The emissions data and the O₂ levels at minimum and maximum input rate can be found on the back side of the front-boiler's door, which can be referenced in the future by the boiler operator(s) when troubleshooting and servicing the boiler. In addition, the following tests and inspections are made on each boiler at the factory to ensure it meets our highest safety and functionality standards.

- ASME hydrostatic test inspection
- Electrical components inspection
- Operating & efficiency test
- Final engineering inspection
- Crating inspection

Danger
DO NOT store or use gasoline or other flammable vapors or liquids in the vicinity of this or any other appliance.
If you smell gas vapors, DO NOT try to operate any appliance—DO NOT touch any electrical switch or use any phone in the building. Immediately, call the gas supplier from a remotely located phone. Follow the gas supplier's instructions or if the supplier is unavailable, contact the fire department.

1.4 Component Description

1. Touchscreen display. The display provides easy access for viewing and adjusting boiler operational parameters, monitoring historical performance characteristics and annunciating boiler alarm/lockout conditions.
2. Boiler On/Off switch.
3. Manual gas shutoff valve. The boiler is equipped with two manual gas shut off valves, one located on the incoming gas supply line outside of the boiler, and the other downstream of the main gas valve.
4. Main gas supply connection.
5. Pressure relief valve. The pressure relief protects the heat exchanger from an over-pressure condition.
6. Ducted combustion air flange.
7. Flue gas vent outlet. The boiler comes with a standard AL 29-4C® stainless steel vent connection.
8. Water flow switch.
9. Return water connection. A 3" diameter Victaulic grooved connection is provided on the ARC1000. A 3", 150# class, flange is provide on the ARC1500 – 3000.
10. Cleanout and inspection. A 3" diameter Victaulic grooved connection is provided for inspecting and cleaning sediment from the heat exchanger.
11. Supply water connection. A 3" diameter Victaulic grooved connection is provided on the ARC1000. A 3", 150# class, flange is provide on the ARC1500 – 3000.
12. Air vent. The boiler is provided with an internal dip tube that traps liberated air from the boiler water. The air vent allows the trapped air to escape from the boiler.

13. Boiler reset push button.
14. Boiler water temperature gauge.
15. Boiler water pressure gauge.

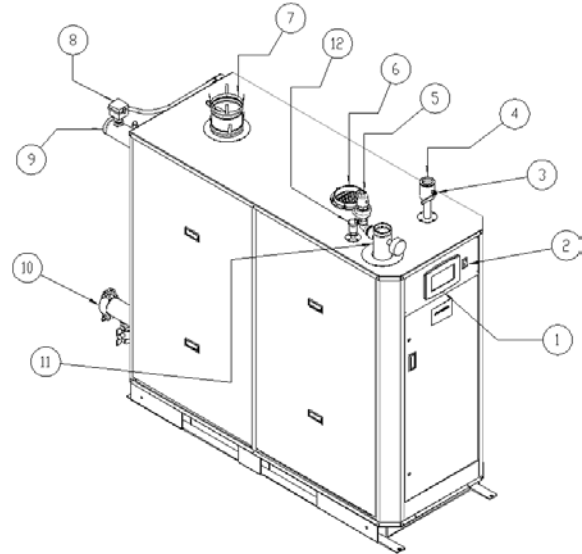

Figure 1: ARC1000 External Boiler Connections and Components

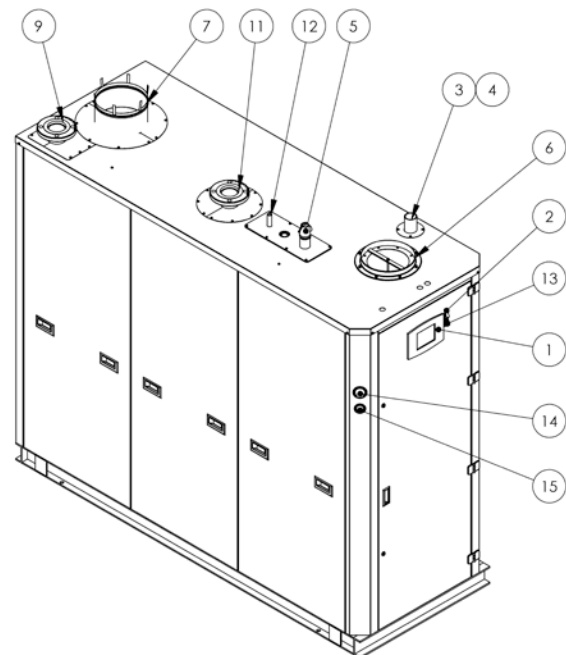

Figure 2: ARC1500 - 3000 External Boiler Connections and Components

2 Pre-Installation

The customer should examine the equipment for any damage. It is the responsibility of the installer to ensure all parts supplied with the equipment are fitted in a correct and safe manner.

WARNING

This boiler requires regular maintenance and service to operate safely. Follow the instructions contained in this manual.

WARNING

Improper installation, adjustment, alteration, service, or maintenance can cause property damage, personal injury or loss of life. Read and understand the entire manual before attempting installation, start-up operation, or service. Only an experienced, skilled installer or service agency must perform installation and service.

WARNING

This boiler must be properly vented.

WARNING

This boiler needs fresh air for safe operation and must be installed so there are provisions for adequate combustion and ventilation air.

2.1 Installation Conformance

Installation must conform to the requirements of the authority having jurisdiction. In the absence of such requirements, installation must conform to the National Fuel Gas Code, NFPA 54/ANSI Z223.1, and/ or CAN/CGA B149 Installation Codes. Where required by the authority having jurisdiction, the installation must conform to the Standard for

Controls and Safety Devices for Automatically Fired Boilers, ANSI/ ASME CSD-1.

2.2 Boiler Foundation

Before uncrating, the boiler location should be prepared. The boiler should set upon a good level concrete floor. If the boiler is not level or the floor is not in good condition, a concrete foundation should be built, the dimensions being larger than the outside dimensions of the boiler base. A 4" high housekeeping pad is suggested.

WARNING

Do not install boiler on combustible flooring.

2.3 Clearances and Serviceability

See Figure 3 and Table 1 for minimum clearances to walls, ceilings, or obstructions. These clearances are intended as a general recommendation only. Local codes must be applied to specific installations and the minimum clearances established accordingly. Provisions must also be made for service, accessibility and clearance for piping and electrical connections. Do not obstruct combustion air and ventilation openings with piping or any other construction. All boilers must be installed in a space that is large compared to the boiler.

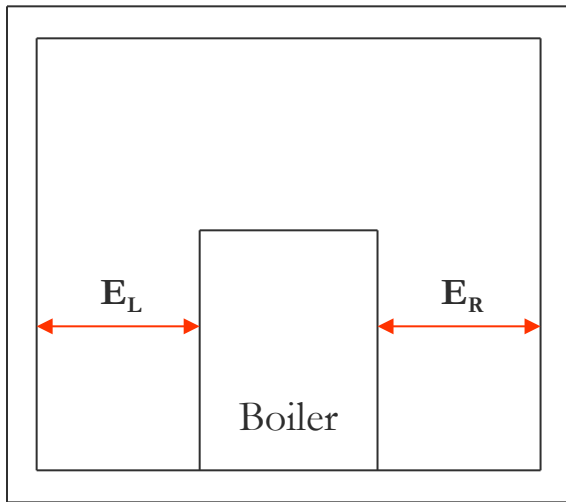
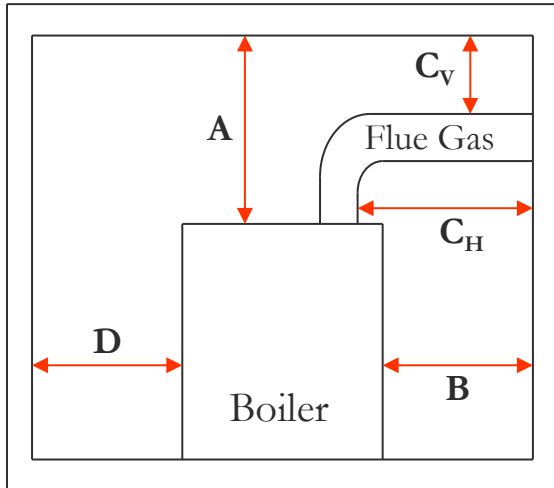

Figure 3: Clearances and Serviceability

Dim	Description	1000	1500-3000
C _V	From Chimney or Vent Collector measured vertically	18"	18"
D	Rear of Boiler - opposite burner end	6"	6"
E _L	Left Side – tube access side on standard construction	16"	23"
E _R	Right Side	6"	6"

Table 1: Clearances and Serviceability

Dim	Description	1000	1500-3000
A	Clearance Above Top of Boiler	6"	6"
B	Front of Boiler – Burner End	24"	25-5/8"
C _H	From Chimney or Vent Collector measured horizontally	18"	18"

3 Installation

3.1 Receiving The Boiler

The boiler is shipped from the factory with (4) shipping feet/legs bolted to the skids. These are provided to facilitate unloading /moving with a forklift. Lifting points are also provided to enable over-head lifting with spreader bars to prevent damage to the boiler. The shipping feet/legs **MUST BE REMOVED** after the boiler is set in-place on its concrete foundation before any piping/electrical connections are made. It is recommended that the plastic protective cover be left on as long as possible to reduce finish damage from the installation.

3.2 Boiler Connections

Do not run any pipes along the tube access panel side of the boiler. Maintain clearances as shown on the dimensional drawing for servicing of the boiler tubes. All piping should be designed and installed to avoid any loadings on the boiler connections or piping.

3.2.1 Flow Connection

The system supply and return flow connections are shown on Figure 1. A gate valve should be installed on the boiler outlet and inlet lines. This allows the boiler to be isolated from the heating system for draining and servicing.

3.2.2 Safety Relief Valves

Safety relief valve(s) are shipped loose. Connections are provided in the top of the boiler for the safety relief valve(s). The safety relief valve discharge piping must be the same size as the safety relief valve discharge opening and run to a point of safe discharge. No shutoff valves are to be placed between the relief valve and the appliance or in the discharge piping. Avoid over-tightening as this can distort valve seats. All piping from the safety relief valve(s) must be independently supported with no weight carried by the valve.

NOTICE

If the relief valve discharges periodically, this may be due to thermal expansion in a closed water supply system. Contact the water supplier or local plumbing inspector on how to correct this situation. DO NOT PLUG THIS RELIEF VALVE.

3.2.3 Expansion Tank Connections

Connection(s) to an expansion tank are to be provided by others in the system piping separate from the boiler.

3.2.4 Drain Connection

A drain valve must be installed on the boiler drain connection, the same pipe size as this connection, to allow draining of the boiler.

3.2.5 Condensate Drain Connection

A condensate drain trap is shipped with the boiler and is provided with a 1" nps connection to drain the condensed products of combustion from the boiler. Pipe with continuous Teflon, high temperature silicone tubing, or other tubing material compatible with flue gas condensate. The condensate temperature should never exceed 212° F and the pH of the condensate should never have a value lower than 3.5. **NO VALVE** is to be

installed in this line from the boiler to point of discharge.

The condensate drain trap should be flushed with water as part of your boiler maintenance schedule to remove any debris that might have accumulated over time.

A common condensate pump/sump may be used. Run separate piping from each condensate drain to the sump. A common drain may be used to discharge condensate from the sump. Consult pump/sump materials of construction. If a common sump is used, individual drain lines should be connected such that one drain cannot back feed into another drain. Use Table 2 for sizing the pump / sump.

Table 2: Typical Condensate Flow Rate	
Model	Max Condensate Flow (gph)
ARC1000	7
ARC1500	10.5
ARC2000	16
ARC2500	21.5
ARC3000	27

Consult local authorities regarding disposal of flue gas condensate into public waste water system. Some jurisdictions require that condensate be buffered before discharge. This buffering is commonly achieved by draining the condensate through a limestone bed. Consult Thermal Solutions or a chemical treatment company for buffering system.

CAUTION

Failure to properly pipe the condensate system will greatly reduce boiler life. Do not install plugs, caps, or valves on condensate piping.

Do not manifold boiler condensate and vent drains together.

Do not crimp condensate lines or reduce drain line inner diameter size.

3.2.5.1 ARC1000 Condensate Drain Trap

Ensure that the condensate drain trap is filled with water prior to running the boiler to prevent flue gas emission to the boiler room.

It is recommended that the personnel responsible for running and maintaining the boiler periodically check the water level in the condensate drain trap bend, especially, when the boiler is operating in a non-condensing condition for an extended period of time.

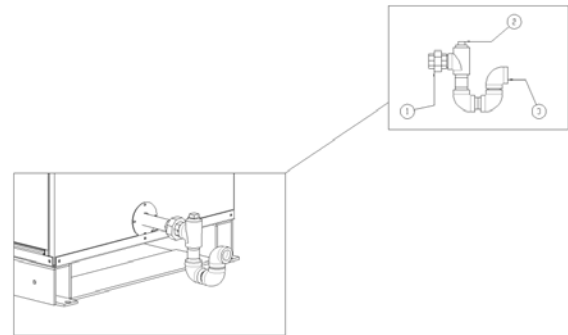
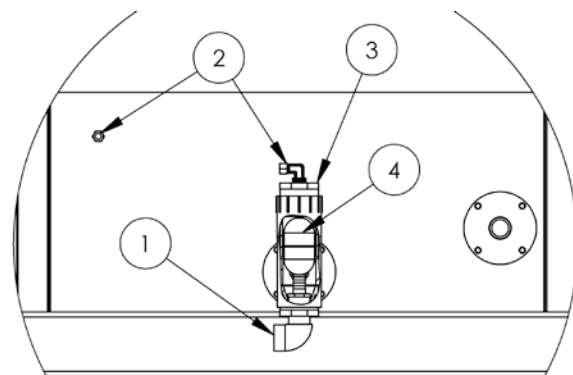

Figure 4: ARC 1000 Condensate Drain Trap

1. Union Connection to the boiler condensate drain line
2. Removable cleaning plug
3. Condensate drain outlet connection

3.2.5.2 ARC1500 – 3000 Condensate Drain Trap



**Figure 5: ARC1500 - 3000 Condensate
Drain Trap**

1. 1" npt outlet connection
2. Trap vent connection (tubing not shown for clarity)
3. 2" threaded cleanout
4. Float ball

3.2.6 Gas Supply Connection

The installation must conform completely to the requirements of the authority having jurisdiction, or in the absence of such, requirements shall conform in the U.S. to the current National Fuel Gas Code, ANSI Z223.1-1984, or in Canada to the current Natural gas and propane installation code (CAN/CSA B149.1-05), and applicable regional regulations for the class; which should be followed carefully in all cases. Authorities having jurisdiction should be consulted before installations are made.

3.2.6.1 Drip Leg

A drip leg, or sediment trap, is supplied with the gas train. The gas line must be connected to a supply main at least as large as the gas train connection at the boiler. This connection should be made with a union so that the boiler gas train components and burner may be easily removed for service.

3.2.6.2 Gas Piping Leak Test

After completion of the gas-piping hookup, the installation must be checked for leaks. Leaks shall be checked using a soap and water solution. All joints up to the main motorized gas valve shall be checked. A pressure gauge shall be installed down stream of the main motorized gas valve and up stream of the manual gas shutoff valve in the closed position to ensure the main motorized valves are not leaking by. During commissioning, the remainder of the gas train joints down

stream of the main motorized gas valve shall be tested for leaks.

3.2.6.3 Venting of Gas Train Components

The MBC (gas valve) has an internal, factory installed vent limiter re ANSI Z21.18/ CSA 6.3. Venting required unless otherwise accepted by the authority having jurisdiction.

The high and low gas pressure switches incorporate a vent limiter as per UL 353 and limits the escape of gas less than 1.0 CFH of natural gas at 7 PSI if internal switch diaphragm ruptures.

3.3 Combustion Air Supply System

For proper combustion it is necessary to provide the boiler room with appropriate openings for fresh air supply. Temporary air intakes such as windows and doors should be avoided since they may be closed. In addition to air needed for combustion, sufficient air must be supplied for ventilation as well as other air consuming equipment that may be present in the boiler room. Often when personnel are working in the boiler room, combustion air openings are closed due to the temperature of the outside air. **THIS MUST BE AVOIDED AT ALL COSTS!** Provisions should be made to heat the outside combustion air, if necessary, for personnel comfort.

Positive means for supplying an ample amount of outside air, allowing for the complete combustion of the gas, must be provided.

Movable combustion air dampers, automatic or manually adjustable, must be electrically interlocked with the boiler to prevent boiler operation if the dampers are closed.

Combustion air openings must never be blocked or obstructed in any manner.

The boiler room must be at a positive or neutral pressure relative to the outdoors. A negative in the boiler room will result in downdraft problems and incomplete combustion due to the lack of air.

WARNING!

Failure to provide an adequate air supply will result in boiler damage and hazardous conditions in the building (fire and asphyxiation hazard as well as equipment damage).

3.3.1 Combustion Air Openings:

The design of combustion air openings MUST comply with local and/or State codes or the authority having jurisdiction. As a minimum, combustion air openings to the boiler room shall be provided as follows:

NOTICE

Combustion air provided solely from an indoor source is discouraged. No dimension for a round or rectangular opening shall be less than 3".

3.3.1.1 Two Permanent Opening Method

One opening starting within 12" of the top of the boiler room and one starting within 12" of the bottom of the boiler room shall be provided. The openings shall be open directly to the outside or ducted directly to the outside.

When directly open to the outside or ducted to the outside by **vertical** ducts, each opening or duct shall have a minimum free open area of 1 in² per 4000 BTU total input rating of the boiler(s) in the room.

If ducted to the outside through **horizontal** ducts, each opening or duct shall have a minimum free area of 1 in² per 2000 BTU total input rating of the boiler(s) in the room.

3.3.1.2 One Permanent Opening Method

One opening commencing within 12" of the top of the room shall be provided. The opening shall be directly to the outside or shall be ducted to the outside with a horizontal or vertical duct.

The opening or duct shall have a minimum free area of:

1 in² / 3000 BTU /hour of the total input rating of all appliances (boilers) in the room.

Additional area must be provided for other air consuming equipment in the room.

3.3.1.3 Mechanical Air Supply Systems

The combustion air supply may be provided by a mechanical air supply system. If utilized, the combustion air must be provided from the outside at a minimum rate of 0.35 ft³/min. for every 1000 Btu/hr. input for all appliances located in the space.

If exhaust fans are utilized, additional air shall be provided to replace the exhausted air.

Each boiler and other appliance must be interlocked to prevent operation when the mechanical air supply system is not in operation.

If the combustion air is provided by a buildings mechanical ventilation system, the system shall be sized to provide the specified combustion air in addition to the ventilation air requirements.

3.3.2 Louvers, Grilles, and Screens

3.3.2.1 Louvers and Grilles:

The required size of openings for combustion, ventilation, and dilution air shall be based on the net free area of each opening. Where the free area through a design of louver, grille, or screen is known, it shall be used in calculating the size opening required to provide the free area specified. Where the louver and grille design and free area are not known, it shall be assumed that wood louvers have a 25 percent free area, and metal louvers and grilles have 75 percent free area. Non-motorized louvers and grilles shall be fixed in the open position.

3.3.2.2 Screens

Minimum Screen Mesh Size:

Screens shall not be smaller than 1/4 " mesh.

3.3.2.3 Motorized Louvers:

Motorized louvers shall be interlocked with the appliance so they are proven in the full open position prior to main burner ignition and during main burner operation. Means shall be provided to prevent the main burner from igniting should the louver fail to opening during burner startup and to shut down the main burner if the louver close during burner operation.

3.3.2.4 Combustion Air Ducts

Combustion air ducts shall comply with the following:

Ducts shall be constructed of galvanized steel or a material having equivalent corrosion resistance, strength and rigidity.

Ducts shall terminate in an unobstructed space, allowing free movement of combustion air to the appliances.

Ducts shall serve a single space.

Ducts shall not serve both upper and lower combustion air openings where both such openings are used. The separation between ducts serving the upper and lower combustion air openings shall be maintained to the source of combustion air.

Ducts shall not be screened where terminating in an attic space.

Horizontal upper combustion air ducts shall not slope downward toward the source of combustion air.

For informational purposes, there are several codes that address the amount of air and/or size of the opening(s) in walls for combustion air.

NFPA 54, National Fuel Gas Code (ANSI Z223.1)

ASME CSD-1, Controls and Safety Devices for Automatically Fired Boilers

ASME Section VI, Recommended Rules for Care and Operation of Heating Boilers

BOCA, National Mechanical Code

WARNING:

Do not locate air intakes where petroleum distillates, CFC's, detergents, volatile vapors or any other chemicals are present. Severe boiler corrosion and failure will result.

3.3.3 Ducted Combustion Air

Ducted combustion air can be connected to the boiler air intake flange. Ducts shall be constructed of galvanized steel or a material having equivalent corrosion resistance, strength and rigidity.

Appendix B shall be used to determine the ducted combustion air system equivalent length. For typical ducted combustion air arrangements see Appendix D.

3.4 Venting Requirements

In order to properly vent this boiler, the installer must select and install a venting system that meets all requirements specified in this section, as well as following the instructions provided by the venting system manufacturer.

1. The venting system shall be designed and constructed in accordance with the National Fuel Gas Code, NFPA 54 / ANSI Z223.1 and applicable local building codes to develop a positive flow adequate to convey flue or vent gasses to the outdoors.
2. If this boiler is being installed in Massachusetts, follow the Massachusetts Code Instructions printed later in this section.
3. Consult the vent pipe manufacturer's instructions for vent system assembly and system specific installation requirements.
4. Vent pipe system shall be acceptable for use with boiler fuel type.
5. Vent pipe system shall be compatible either by directly connecting, or by using an adaptor, to the boiler vent connection.
 - a. This boiler is shipped with an AL 29-4C[®] Heat-Fab Saf-T-Vent connection.
 - b. Alteration of the boiler vent connection is prohibited.
6. Do not reduce the diameter of the vent pipe. The vent pipe must not be smaller than the vent connector on the boiler.
7. Vent pipe system must be adequately supported at intervals no less than five (5) feet apart. The completed vent system must be rigid and able to withstand impacts without collapse.
8. The boiler's venting is Category IV (positive vent pressure, flue condensing), with regards to the National Fuel Gas Code, NFPA 54 / ANSI Z223.1.
9. Vent pipe system must be fully sealed.
10. Atmospheric venting is prohibited.
11. Common venting is acceptable. Common vents serving multiple boilers shall be designed so that flue gasses will not expel to the room through a boiler on standby. The common vent system shall be capable of maintaining a neutral to slightly negative draft pressure at all times. This is normally accomplished with a mechanical draft fan. Common venting with any other appliances is prohibited.
12. Appendix B shall be used to determine the vent system equivalent length.
13. It is permissible to run vent pipe through a vertical or horizontal chase provided minimum clearances to combustible materials are maintained.
14. The minimum clearance to combustible material is six (6) inches unless otherwise specified by the manufacturer.
15. The vent termination location is restricted as follows:
 - a. Minimum twelve (12) inches above grade plus normally expected snow accumulation or seven (7) feet above grade if located adjacent to public walkways. DO NOT INSTALL over public walkway where local experience indicates condensation or vapor from the boiler creates a nuisance or hazard.

- b. Minimum three (3) feet above any forced air inlet located within ten (10) feet of the vent termination.
 - c. Minimum four (4) feet below, four (4) feet horizontally or one (1) foot above any door, window or gravity air inlet.
 - d. Minimum four (4) feet horizontally from electric meters, gas meters, regulators and relief valves. This distance may be reduced if equipment is protected from damage due to condensate or vapor by enclosure, overhangs, etc.
16. Use appropriately designed thimbles when passing through combustible walls or roofs.
 17. Install fire-stops where vent passes through floors, ceilings or framed walls. The fire-stop must close the opening between the vent pipe and the structure.
 18. Enclose vent passing through occupied or unoccupied spaces above the boiler with materials having a fire resistance rating at least equal to the rating of the adjoining floor or ceiling. Maintain minimum clearance to combustible materials.
 19. Locate vent terminal above combustion air intake terminal (if used) and no closer than (1) foot horizontally.
 20. Vertical venting requires flashing and a storm collar to prevent moisture from entering the structure.
 21. Vertical vent termination must be at least two (2) feet plus the expected snow accumulation above roof penetration height.
 22. This boiler has been certified with AL29-4C[®] venting. Select a vent material that is approved for use with condensing flue gasses.
 23. Install vent system before installing air intake, water, gas or electrical connections.
 24. For instances where the vent system manufacturer's instructions do not make a specification, refer to the below points.
 - a. Make sure pipe and fittings are clean by swabbing with alcohol. Use Dow Corning 736 or 732 RTV, Polybar # 500 RTV or Sil-Bond 4500 or 6500 or seal vent pipe.
 - b. Refer to the appropriate drawings in Appendix C of this manual to determine common acceptable configurations of the vent system.

WARNING

Improper venting may result in property damage and the release of flue gasses that contain deadly carbon monoxide (CO) into the building, which can cause severe personal injury and/ or death.

WARNING

Do not use a barometric damper with this boiler. This is a positive pressure system. The use of a barometric damper may cause flue gases to leak into the boiler room.

3.4.1 Massachusetts

The commonwealth of Massachusetts requires compliance with regulation 248 CMR 4.00 to 5.00 for installation of sidewall venting gas appliance as follow.

For all side wall horizontally vented gas fueled equipment installed in very dwelling, building or structure used in whole or in part for residential purpose, including those owned or operated by Commonwealth and where the side wall exhaust vent termination is less than seven (7) feet above finished grade in the area of the venting, including but not limited to decks and porches, the following requirements shall be satisfied.

1. **INSTALLATION OF CARBON MONOXIDE DETECTORS:** At the time of installation of

- the side wall venting gas fueled equipment, the installing plumber or gasfitter shall observe that a hard wired carbon monoxide detector with an alarm and battery back-up is installed on the floor level where the gas equipment is to be installed. In addition, In addition, the installing plumber or gasfitter shall observe that a battery operated or hard wire carbon monoxide detractor with an alarm is installed on each additional level of dwelling, building or structure served by the side wall horizontal vented gas fueled equipment. It shall be the responsibility of the property owner to secure the service of a qualified licensed professional for the installation of hard wired carbon monoxide detectors.
- a. In the event that the side wall horizontally vented gas fueled equipment is installed in a crawl space or an attic, the hard wired carbon monoxide detectors with alarm and battery back-up may be installed on the next adjacent floor level.
 - b. In the event that the requirements of this subdivision cannot be met at the time of completion of installation, the owner shall have a period of (30) days to comply with the above requirements; provided, however, that during said (30) day period, a battery operated carbon monoxide detector with an alarm shall be installed.
2. **APPROVED CARBON MONOXIDE DETECTORS.** Each carbon monoxide detector, as required in accordance with the above provisions, shall comply with NFPA 720 and be ANSI/UL 2034 listed and IAS certified.
 3. **SIGNAGE.** A metal or plastic identification plate shall be permanently mounted to the exterior of the building at a minimum height of eight (8) feet above grade directly in line with the exhaust vent terminal for the horizontally vented gas fueled heating appliance or equipment. The sign shall read, in print size no less than one-half (1/2) inch in size, "GAS VENT DIRECTLY BELOW. KEEP CLEAR OF ALL OBSTRUCIONS."
 4. **INSPECTION.** The state or local gas inspector of the side wall horizontally vented gas fueled equipment shall not approve the installation unless, upon inspections, the inspector observes carbon monoxide detectors and signage installed in accordance with the provisions of 248 CMR 5.08(2)(a)1 through 4.
 - a. **EXEMPTIONS:** The following equipment is exempt from 248 CMR 5.08(2)(a)1 through 4:
 - i. The equipment listed in chapter 10 entitled "Equipment Not Required To Be Vented" in the most current edition of NFPA 54 as adopted by the Board; and
 - ii. Product Approved side wall horizontally vented fueled equipment installed in a room or structure separate from the dwelling, building or structure used in whole or in part for residential purposes.
 - b. **MANUFACTURER REQUIREMENTS-GAS EQUIPMENT VENTING SYSTEM PROVIDED.** When the manufacturer of Product Approved side wall horizontally vented gas equipment provides a venting system design or venting system components with the equipment, the instructions provided

by manufacturer for installation of the equipment and the venting system shall include:

- i. Detailed instructions for the installation of the venting system design or the venting system components; and
 - ii. A complete parts list for the vent system design or venting system.
- c. **MANUFACTURER REQUIREMENTS-GAS EQUIPMENT VENTING SYSTEM NOT PROVIDED.** When the manufacturer of a Product Approved side wall horizontally vented gas fueled equipment does not provide the parts for venting the flue gases, but identifies “special venting systems”, the following requirements shall be satisfied by the manufacturer:
- i. The referenced “special venting system” instructions shall be included with the appliance or equipment installation instructions; and
 - ii. The “special venting systems” shall be Product Approved by the Board, and the instructions for the system shall include a parts list and detailed installation instructions.
- d. A copy of all installation instructions for all Product Approved side wall horizontally vented gas fueled equipment, all venting instructions, all parts lists for venting instructions, and/or all venting design instructions shall remain with appliance or equipment at the completion of the installation instructions.

3.4.2 Combustion Air and Venting Requirements for Canada

Canadian Standard CAN/CSA-B149.1-05, Natural gas and propane installation code specifies venting systems and air supply for appliances in Section 8. Paragraph 8.1.4 states “Air supply shall be provided in accordance with Clause 8.4 when either an appliance or a combination of appliances has a total input exceeding 400,000 Btuh. Air supply is defined as combustion air, excess air, flue gas dilution air, primary air, secondary air, and ventilation air. The air supply requirements below are a summation of Clause 8.4 specific to this boiler.

3.4.2.1 Air Supply Requirements per CAN/CSA-B149.1-05 for Appliances having an input exceeding 400 MBH.

Ventilation Air: an opening for ventilation air at the highest point that opens to the outdoors shall provide Ventilation of the space. The cross sectional area of this opening shall be at least 10% of the area required for combustion air, but in no case shall the cross-sectional area be less than 10 in² (6500mm²).

Combustion Air: For combustion air where the air supply is provided by natural airflow from outdoors, in addition to the opening for ventilation air, there shall be permanent opening having a total cross-sectional free area of not less than 1 in² for each 30,000 BTU/hr. (70 mm² for each kW) of the total rated input of the boiler(s). The location of the opening(s) shall not interfere with the openings for ventilation air. Please refer to CAN/CSA-B149.1-05, Para. 8.4.4, for combustion air openings if there are natural draft, fan assisted or power draft assisted equipment in the space.

When an air supply duct is used to supply combustion air, its discharge opening shall be

located where there is no possibility of cold air affecting steam or water lines or other temperature sensitive equipment.

3.4.2.2 Combustion Air Supply Dampers, Louvers, and Grilles

The free area of the combustion air supply opening shall be calculated by subtracting the blockage area of all fixed louvers, grilles or screens from the gross area of the opening.

Openings in a fixed louver, grille, or screen shall have no dimension smaller than ¼” (6 mm).

No manually operated damper or manually operated adjustable louvers are permitted.

A motorized damper or louvers shall be interlocked so the burner(s) cannot operate unless the damper or louver is in the fully open position.

3.4.2.3 Mechanical Combustion Air Supply

When combustion air is supplied by mechanical means, an airflow sensing device shall be installed and wired into the safety limit circuit of the primary safety control to shut off the gas in the event of an air supply failure.

3.4.2.4 Appliance Venting per CAN/CSA-B149.1-05

Paragraph 8.9 of CAN/CSA-B149.1-05 addresses “Appliance Venting”. Paragraphs 8.9 through 8.31 address many facets of flue gas vents, many of which do not apply to the this boiler, which is a Category IV listed appliance requiring the use of special venting systems as previously described.

NOTICE

Please note that the information provided in this manual relative to the Canadian Standard is not meant to be all-inclusive. Reading the entire Standard is strongly suggested. The final approval of all system designs must be acceptable to the authority having jurisdiction.

- Venting for Category IV appliances shall be as specified or furnished by the manufacturer of the listed appliance. This boiler is a Category IV appliance requiring the use of special vent that is certified.
- A special venting system shall be installed in accordance with the terms of its listing and the vent manufacturers certified installation manual.
- A flue gas vent or a vent connector shall not be installed in either a duct or a shaft used for return air, hot air, ventilating air, or combustion air.
- An appliance that operates at a positive vent pressure shall not be connected to a venting system serving any other appliance. This boiler operates at a positive vent pressure.
- A factory-built chimney used for venting an appliance shall be certified.

3.5 Requirements

3.5.1 Electrical

WARNING

All electrical connections must conform to the National Electrical Code, ANSI / NFPA 70 and / or CSA C22.1 Electrical Code and all other State and Local codes.

A separate electrical circuit must be run from the main electrical service with an over-current device/disconnect in the circuit. A service switch is recommended and may be required by some local jurisdictions. Locate the service switch such that the appliance can be shut off without exposing personnel to danger in the event of an emergency. See Table 3 for available voltages.

Table 3: Electrical Requirements				
ARC1000				
Voltage	FLA	CCA	MHP	MA
120/1/60	6.6	2.6	.46	4
ARC1500				
Voltage	FLA	CCA	MHP	MA
208-240/1/60	6.9	2.6	1.1	4.3
ARC2000 to ARC3000				
Voltage	FLA	CCA	MHP	MA
208-240/1/60	8.3	2.6	1.5	5.7
208-240/3/60	9.5	2.6	3	6.9
480/3/60	6.6	2.6	3.2	4
FLA = Full Load Amps : CCA = Control Circuit Amps : MHP = Motor Horse Power : MA = Motor Amps				

Connect field supplied safety limits or devices using proper terminals provided in boiler electrical cabinet. Refer to wiring diagram supplied with boiler for wiring information.

See Appendix G for sample-wiring diagrams. An as-built wiring diagram is included with every boiler when it ships. Contact a Thermal Solutions Representative or visit the website (www.thermalsolutions.com) for current wiring options.

3.5.2 Gas Supply Requirements

Refer to Table 4 for minimum and maximum gas supply pressure. When the gas supply pressure exceeds the maximum, an additional field supplied regulator will be required to reduce the supply pressure. For proper gas supply sizing refer to Appendix A.

Model	Capacity (SCFH)	Inlet (nps)	Min. (iwc)	Max. (iwc)
ARC1000	1000	1	4	14
ARC1500	1500	2	4	14
ARC2000	2000	2	4	14
ARC2500	2500	2	4	14
ARC3000	3000	2	4	14

Table 4: Gas Supply Requirements

3.5.3 Sound Pressure Levels

Sound pressure levels were measured at 4-1/2' above the floor and 3' from the boiler at the front, rear and two sides. See Table 5 for decibel readings.

Table 5 Sound Pressure Levels				
Model	Decibel Levels			
	Front	Rear	Tube Side	Right Side
ARC1000				
ARC1500	67	60	61	63
ARC2000	67	60	61	63
ARC2500	62	62	66	61
ARC3000	62	62	66	61

3.5.4 Pump and Piping Requirements

Pump piping and system piping must meet the requirements of local codes and jurisdictions. Good engineering practices should be followed and considered for each piping system used.

It is advised that the circulating pump for each boiler be installed as close to the boiler as possible in the line to the return connection such that system water is pumped towards the boiler.

Installing circulating pumps so that the water is pumped away from the boiler is rarely recommended.

Means to eliminate air from the boiler/piping systems is a must. It is advised that an air separator be installed as close as practical to each boiler in the outlet pipe. Further, an air vent should be installed at all high points throughout the piping system.

It is recommended that a water meter be installed in the make-up water system to the boiler system. Scheduled recording of the water meter register will show an indication of a potential slow system leak in addition to providing insight into any system problems. Also, make-up water as well as water for the initial system fill should be provided through a water softener. Additionally, chemical treatment of the system water is advisable. Contact a qualified boiler water chemical treatment company for their recommendations. See section 3.8 for more information.

See Appendix F for boiler water flow pressure drop data and Appendix E for typical boiler piping arrangements.

3.5.4.1 Water Flow Rates (Variable Primary Pumping Systems)

Variable primary pumping systems shall be capable of delivering no less than the minimum and no more than the maximum specified in Table 6 and Table 7 for each boiler connected in the system.

Model	Minimum Flow Rate		
	gpm	ΔP (ft)	Low Fire ΔT
ARC1000	4	.04	100F
ARC1500	6	.02	100F
ARC2000	8	.03	100F
ARC2500	10	.04	100F
ARC3000	12	.05	100F

Table 6 Minimum Water Flow Rates for Variable Primary Pumping

Model	Maximum Flow Rate		
	gpm	ΔP (ft)	High Fire ΔT
ARC1000	95	12.7	20F
ARC1500	143	9.2	20F
ARC2000	190	16.3	20F
ARC2500	238	20	20F
ARC3000	285	28.7	20F

Table 7 Maximum Water Flow Rates for Variable Primary Pumping

WARNING

Do not use Table 6 or Table 7 to size a constant volume pump.

3.5.4.2 Water Flow Rates (Primary / Secondary Systems)

Each boiler connected to a secondary loop of a primary / secondary pumping system shall have a constant volume pump sized in accordance with Table 8 or Table 9.

Model	20 F ΔT Flow Rate			
	gpm	ΔP (ft)	High Fire ΔT	Low Fire ΔT
ARC1000	95	12.7	20F	4F
ARC1500	143	9.2	20F	4F
ARC2000	190	16.3	20F	4F
ARC2500	238	20	20F	4F
ARC3000	285	28.7	20F	4F

Table 8 Water Flow Rates for Primary / Secondary Pumping 20F ΔT

Model	40 F ΔT Flow Rate			
	gpm	ΔP (ft)	High Fire ΔT	Low Fire ΔT
ARC1000	48	3.18	40F	8F
ARC1500	71	2.3	40F	8F
ARC2000	95	4.08	40F	8F
ARC2500	119	5	40F	8F
ARC3000	143	7.18	40F	8F

Table 9 Water Flow Rates for Primary / Secondary Pumping 40F ΔT

3.5.4.3 Water Flow Rates (Constant Volume Primary Pumping Systems)

A constant volume primary pumping system shall be sized so that the flow rate specified in Table 10 can be maintained through each boiler connected to the system.

Model	Maximum Flow Rate		
	gpm	ΔP (ft)	High Fire ΔT
ARC1000	95	12.7	20F
ARC1500	143	9.2	20F
ARC2000	190	16.3	20F
ARC2500	238	20	20F
ARC3000	285	28.7	20F

Table 10: Water Flow Rates for Constant Volume Primary Pumping

3.5.4.4 Water Flow Rates for Glycol

For glycol systems the gpm in Table 6, Table 7, Table 8, Table 9, and Table 10 will increase as specified in Table 11.

Glycol Concentration	GPM Percent Increase
50%	24%
30%	14%

Table 11 GPM Increase for Glycol Systems

3.6 Before Placing Boiler In Operation

3.6.1 Pre-Boil Out Flushing Of System

Much of the dirt and contamination in a new hot water system can be flushed out before the boil out of the system. First, flush the system of waste with clear water. The boiler and circulating pumps must be isolated through the successive zones of the system to waste, carrying metal shavings, dirt, pipe joint compound, etc. with it. Follow with a chemical flush.

WARNING

Be CERTAIN that the chemicals used to flush and boil-out the boiler and system contain NO CHLORIDES. The boiler is fabricated with austenitic stainless steels that can be severely damaged when exposed to chlorides.

The removal of pipe chips and other debris from the system before opening the isolation valves to the boiler and pumps will help to protect this equipment from damage by such debris.

In combination with system contamination, bacteria from ground water boiler water may produce objectionable odors, sometimes resembling the odorant used in natural gas. It is important to keep these fumes from air intakes that would distribute them throughout the building.

3.6.2 Boil Out Procedure**WARNING**

The boil out procedure outlined must be performed by, or under the direct supervision of, a qualified technician. The chemicals used present a hazard of burns and physical injury if mishandled. Always use a suitable facemask, goggles, protective gloves, and garments when handling caustic chemicals. Do not permit the chemical to come into contact with skin or clothing. Always follow the safety precautions on the container's label. Add chemicals slowly and in small amounts to prevent excessive heat and agitation.

The boil out of the boiler and system is neither difficult nor expensive. The chemicals needed for cleaning are readily available. Tri-sodium phosphate, and sodium hydroxide (lye) are the most commonly used chemicals. Be certain the chemicals used contain NO CHLORIDES. Use only one type of solution in the system. The amount of chemical required will vary according to conditions, but one pound per fifty gallons of water is suggested.

Fill the system with this solution, venting all air. Then, with the circulating pump running, bring the system to design or operating temperature. After circulating water for two to three hours, the system should be drained completely, and refilled with fresh, softened water see section 3.8. Usually enough of the cleaning solution will adhere to the piping to result in an alkaline solution satisfactory for operation. A pH reading between, 8.3 – 10.5 is preferred. If necessary, to increase the pH, a small amount of cleaner may be added.

3.6.3 Replacement Boiler Installations

Clean or replace all system piping and heating units.

Arrange for chemical or mechanical cleaning of the entire system. A chemical treatment company should be consulted for the proper means of any chemical cleaning. Replace any piping that is deteriorated beyond safe or cleanable condition.

Flush the system clean, being certain to isolate the boiler.

WARNING

Do not flush the system through the boiler.

For some old systems, there is a reluctance to clean the piping because of possible leaks occurring in badly corroded lines. Should the customer refuse cleaning, it is necessary to install filtration equipment. Install either a fibrous filter or a centrifugal filter in the boiler return piping. This will collect and remove sediment from the system. A booster pump may be required to overcome the additional pressure drop introduced in the line by the filter. When filling the system, provide chemical treatment as outlined in Section 3.8.

Failure to properly clean the system or to install mechanical sediment removal equipment can result in tube blockage and severe corrosion plus damage to pumps, controls, and air removal devices.

Inspect, repair as necessary, or replace system air control devices.

Install gauge glasses on air expansion tanks and install a tank fitting in the system connection to the tank.

Install a strainer in the boiler return piping.

3.7 Draining and refilling the boiler & system

If the system is drained and then refilled, chemical treatment is essential to treat the raw water. Use only clean, softened water.

3.7.1 Filling The System

WARNING

Use only clean, softened, and treated water. Chemical treatment of the raw water is essential when filling or refilling the system see section 3.8.

3.7.2 Hydrostatic Test Of Boilers And System

After completing the boiler and burner installation, the boiler connections, fittings, attachments and adjacent piping must be inspected for leaks by filling the unit with water. The pressure should be gradually increased to a pressure just below the setting of boiler safety relief valve(s).

Remove the boiler tube access panels (see dimensional drawing in the boiler manual). Inspect the tube to header joints to be certain that all tube fittings are sealed. This is necessary because, although the boiler is hydrostatically tested at the factory, minor leaks in fittings and at attachments can develop from shipping vibration or from installation procedures. Replace tube access panels before proceeding to start boiler.

3.8 Boiler Water Treatment

3.8.1 Purpose of water treatment

Water treatment is required for satisfactory operation of the boiler. It must be devised to prevent depositing of scale and corrosion from acids, oxygen and other such harmful elements that may be in the water supply. A qualified water treatment chemist should be consulted and the water systematically treated.

“Hot water systems must operate with a pH above 8.5. A system that has a pH below 8.5 will usually develop the following problems:

1. Gas formation (air trouble)
2. Pump seal and gland problems
3. Air vents sticking and leaking
4. Frequent relief valve operating
5. Piping leaks at joints

(American Boiler Manufacturers Association [ABMA], 2005. Boiler Water Quality Requirements and Associated Steam Quality for Industrial / Commercial and Institutional Boilers)”

See Table 12 for examples of typical chemical agents found in untreated water along with their potential effects.

3.8.2 Objectives

The basic objectives of water treatment are:

Prevent the accumulation of scale and deposits in the boiler.

1. Remove dissolved gases from the water.
2. Protect the boiler against corrosion.
3. Maintain the highest possible boiler fuel efficiency.
4. Decrease the amount of boiler down time from cleaning.

3.8.3 Water softener

It is highly recommended that a zeolite water softener be used for all make-up to the boiler. It is intended that this be used in addition to the chemical treatment of the boiler. Water softening removes calcium and magnesium, the primary causes of hard boiler scale.

3.8.4 Continuous Monitoring

Water treatment should be checked and maintained according to Table 13 whenever the boiler is operating. The boiler operator should be sure that the boiler is not operating for long periods without proper water treatment.

Water treatment may vary from season to season or over a period of time. Therefore, the water treatment procedure should be checked not less than four times a year, and possibly more frequently as the local water conditions may indicate.

Table 12: Chemical Agents and Effects

Compound	Effect
Calcium Carbonate, (CaCO ₃)	Soft Scale
Calcium Bicarbonate (CaHCO ₃)	Soft scale, CO ₂
Calcium Sulphate (CaSO ₄)	Hard Scale
Calcium Chloride (CaCl ₂)	Corrosion
Magnesium Carbonate (MgCO ₃)	Soft Scale
Magnesium Bicarbonate (MgHCO ₄)	Corrosion, Scale
Magnesium Sulphate (MgSO ₄)	Corrosion
Silicon Dioxide (SiO ₂)	Hard Scale

It should be noted that water boilers may well need chemical treatment for the first filling plus additional periodic chemical treatment, depending on system water losses and the makeup requirements.

All water introduced into the boiler should be softened and should include an oxygen scavenger like sodium sulfite. This is required to remove dissolved oxygen from the water. Dissolved oxygen will cause severe system corrosion.

Dissolved Oxygen	< 0.007 ppm	
Total Iron	≤ 0.1 ppm	
Total Copper	≤ 0.05	
Total Hardness	≤ 9 ppm	≤ 0.5 grains/gal
pH	8.3 – 10.0	
Nonvolatile TOC	< 1 ppm	
Oily Matter	< 1 ppm	

Table 13 Recommended Feed Water Limits

CAUTION
Thermal Solutions Standard Warranty does not cover problems caused by oxygen contamination of boiler water.
Thermal Solutions Standard Warranty does not cover problems caused by scale build-up.
When using Glycol products, all Glycol manufacturers' requirements, including rust inhibitors, must be adhered. Max 50% Glycol.



WARNING
Chemicals used in treating boiler water are toxic and/or harmful. Always use protective clothing and equipment when working with/near chemicals. Contact local authorities to determine if treated boiler water can be discharged into local waste water system.

4 SYSTEM START-UP

WARNING

Completely read, understand and follow all instructions in this manual, Concert Boiler Control manual, and all other component manuals supplied with this boiler before attempting start-up.

4.1 Concert Boiler Control Display Navigation

- This boiler is equipped with a color touch screen display, which presents information and control options in a page manner. Pages are arranged in a tree structure through which the user navigates up and down to arrive at the desired function. The page descriptions and a complete list of the available control parameters are provided in a separate instruction manual for the Concert boiler control (Also supplied with the boiler).
- Most pages have a Home button  in the top-left corner of the screen. The Home button returns the user to the Home page to view real time operation of the boiler.
- The back button  returns the user to the previous page.
- A padlock  icon will be shown on the screens that require the user to enter a password to change the parameter. An unlocked padlock indicates the correct password has been entered to change the parameter.
- The user can access the following icons from the Home screen: Menu,

Info, Status, Adjust, and Help. It is important that the user become familiar in accessing additional icons that are not shown on the home screen page.

NOTICE

Refer to the Concert Boiler Control manual for detailed instructions on the use of the hydronic control and display.

4.2 System Check:

1. Verify that the venting, water piping, gas piping and electrical system are installed properly. Refer to installation instructions contained in this manual.
2. Confirm all electrical, water and gas supplies are turned off at the source and the chimney/vent is clear of obstructions. If boiler is controlled by an external control system, this system must be temporarily disconnected. The local boiler controls should be allowed to operate the boiler.
3. Confirm that all manual shut-off valves between the boiler and gas supply are closed.

4.3 Power the Boiler:

Turn on the electrical supply to the boiler and circulation system at fused disconnect switch. Ensure that the circuit breaker switch is in the "ON" position.

4.4 Power the Circulators:

Turn system circulators on and purge air from the boiler and system piping.

4.5 Pressurize the Fuel System:

1. Open the manual gas shut-off valves located upstream of the field supplied gas

regulator. Do not open manual gas valve directly outside the boiler jacket.

2. Purge gas line of air.
3. Open manual ball valve outside boiler jacket. Confirm that the supply pressure to the manual ball valve tapping outside the boiler jacket conforms to Table 4 for maximum and minimum supply pressure.
4. Repeat steps 2 and 3 for boiler gas train components.
5. Reset low gas pressure safety switch.

4.6 Select Operational Mode:

Refer to the Concert Boiler Control manual to select the desired control features. Allow the boiler to complete its standard startup procedure (pre-purge, pre-ignition, and light-off), and once again using the gas leak detector, inspect the fuel gas train both inside and outside of the boiler for gas leakage.

4.7 Begin Commissioning the Boiler:

Measure gas pressure at tapping on manual gas valve at boiler inlet and confirm that the inlet gas pressure is within the acceptable range found in Table 4 at high and low fire.

1. Confirm that Oxygen (O₂) level in the boiler's flue gas is within 3.8 to 4.2% at high fire and 4.3 to 4.7% at low fire. Refer to Figure 6 for throttle adjustment.

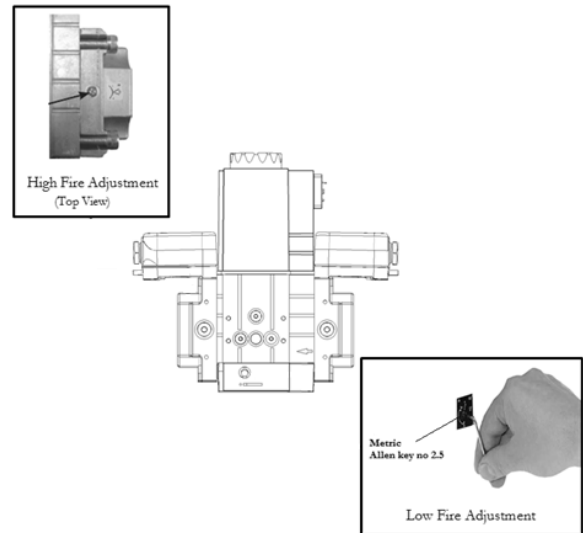

Figure 6: High and Low Fire Adjustments on the Main Gas Valve Regulator

DANGER

Failure to properly adjust excess air will result in unsafe level of carbon monoxide. Variations in venting or combustion air pressure and temperature will change excess air. Adjust excess air levels so that variation in venting or combustion air pressures and temperatures caused by change of seasons, wind conditions, opening or closing of boiler room doors or windows do not cause the boiler to operate with carbon monoxide concentration above 400 parts per million.

- a. Turn throttle clockwise to increase gas.
- b. Turn throttle counter clockwise to decrease gas.
- c. After each adjustment, close all jacket panels and doors and wait until O₂ level has stabilized before making any additional adjustments. This may take approximately 15 minutes.

2. Confirm the high and low gas pressure switches are functioning and are adjusted to prevent over firing or under-firing of the boiler.
3. Verify that all safety and operating limits and flame controls are operating properly.
4. With boiler running, front door closed and all jacket panels attached, measure oxygen (O₂) and carbon monoxide (CO) concentrations in the flue gas and flue gas temperature. Compare results with values given on factory fire test report supplied with boiler.
5. Repeat if necessary.

4.8 Finish Commissioning the Boiler:

Reconnect any wires from the external control system, if applicable.

1. Test function of external control system.
2. Place system control back in normal operation, if necessary.

4.9 Re-Starting After Prolonged Shutdown

Use the following recommendations prior to re-starting the heating system after prolonged shutdown.

1. Perform Pre-Start-Up Inspection by checking all gas, water, air intake and venting connections to ensure proper, leak-free connections and that the water and gas lines has been cleaned completely.
2. Ensure that combustion air piping, vent piping, and terminations are free of obstructions.
3. Inspect the boiler for damage and loose wire connections.
4. Remove all flammable material present in the vicinity of the boiler.

4.10 Testing of Controls and Safety Devices

Prior to placing the boiler in operation, the installing contractor or other responsible personnel must perform safety and control device limit tests to ensure proper operation of the appliance. Refer to Table 14 for recommended method(s) of carrying out these safety limit devices tests.

Component	Test Method(s)	After Lockout Annunciation	Actual Alarm Message
Low Gas Pressure Switch	Increase the setting of the switch until the switch trips.	Manually reset the Concert Boiler Control and switch. Adjust the switch to its normal setting.	Hard Lockout. Gas Pressure Switch
Low Water Cutoff	Push and hold the LWCO test button until the boiler control shuts down the main burner.	Manually reset the Concert Boiler Control and reset the LWCO.	Hard Lockout. Low Water Level
Auto Reset (High Temp) Limit	Lower the setting of the limit so that the boiler control shuts down the main burner.	Adjust the limit to its normal setting.	High Limit Auto Reset
Water Flow Switch	Reduce the water flow rate with a manual shutoff valve until the boiler shuts down.	Adjust manual valve to normal position.	Low Water Flow

4.11 Ignition Failure

After the first ignition failure, the boiler goes into a hard lockout and a manual reset of the Concert Boiler Control is required to restart the boiler. The boiler will then attempt to light off after it has completed its post-purge process.

DANGER

Contact the boiler manufacturer or a qualified heating service technician if the boiler has failed to light consecutively three times after initially resetting the Concert boiler control.

5 Service, Maintenance, and Inspection

5.1 General Maintenance:

1. Follow any checks and/or inspections that may be required as specified in the component manufacturers' instruction manuals.
2. Repair or replace any defective components immediately.
3. The following service procedures are required for proper and safe boiler operation.

DANGER

This boiler uses flammable gas, high voltage electricity, moving parts, and very hot water under high pressure. Assure that all gas and electric power supplies are off and that the water temperature is cool before attempting any disassembly or service.

More than one gas shut-off valve and electrical disconnect switch are used on the boiler. Assure that all gas valves and electrical disconnect switches are off before attempting any disassembly or service.

Do not attempt any service work if gas is present in the air in the vicinity of the boiler. Never modify, removed or tamper with any control device.

Do not use matches, candles, open flames or other ignition source to check for leaks.

WARNING

This boiler must be serviced and repaired by skilled and experienced service technicians only.

If any controls are replaced, they must be replaced with identical models supplied by Thermal Solutions.

Read, understand and follow all the instructions and warnings contained in all the sections of this manual. The instructions and warnings contained in all of the component instruction manuals.

If any electrical wires are disconnected during service, clearly label the wire and ensure that the wires are reconnected properly.

Never jump out or bypass any safety or operating control or components of this boiler.

Assure that all safety and operating controls and components are operating properly before placing boiler back in service.

WARNING

The service instructions contained in this manual are in addition to the instructions provided by the manufacturer of the boiler components. Follow component manufacturer's instructions. Component manufacturer's instructions were provided with the boiler. Contact component manufacturer or Thermal Solutions for replacement if instructions are missing. Do not install, start up, operate, maintain or service this boiler without reading and understanding all of the component instructions. Do not allow the boiler to operate with altered, disconnected or jumpered components. Only use replacement components identical to those originally supplied by Thermal Solutions.

All cover plates, enclosures, and guards must be in place at all times, except during maintenance and servicing.

5.1.1 DAILY:

1. Make visual inspection of gauges, monitors, and indicators and record readings in boiler log.

2. Make visual check of instrument and equipment settings against factory recommended specifications.
3. Check operation of probe type low water cutoff(s) to ensure control is functioning.
4. Check gas train for gas leaks and water piping for any leaks.
5. Confirm boiler area is free of combustible materials and that there is nothing obstructing air intake and vent.

5.1.2 WEEKLY:

1. Check combustion safety controls for flame failure (or other alarm messages).
2. Check all limit controls and low water cutoff as described above.
3. Check condensate drains for any obstructions.
4. Check carbon monoxide level in flue products.

5.1.3 MONTHLY:

1. Check high and low gas pressure interlocks. Refer to manufacturer's instructions for correct procedure.
2. Check proper operation of safety relief valve.
3. Check water quality and correct if needed.
4. Inspect boiler air filter.

5.1.4 ANNUALLY:

1. The flue gas passages and the exterior surfaces of the boiler tubes should be inspected at least once annually. Any accumulation of soot or debris should be thoroughly cleaned out.

2. If inspection of the boiler tube surfaces reveals a build-up of soot (carbon), the tube surfaces should be thoroughly brushed. Failure to do so may result in reduced efficiency, fire and asphyxiation hazards.
3. The boiler pressure vessel and piping should be checked annually.
4. Inspect the ignition rod for carbon build up.
5. Inspect lens of the ultra-violet (uv) scanner and remove any debris with soft cloth and make sure that hole is clear from scanner to burner.
6. Replace air filter.

5.2 Ignition Assembly Cleaning

1. Disconnect power and shut off the external manual gas valve to the boiler prior to removing the ignition assembly.
2. When removing the igniter, extra caution must be taken to prevent damaging the ceramic insulator.
3. Remove any excess oxide deposits from the surface of the igniter with steel wool or emery cloth. Do not use sandpaper.
4. Inspect the ceramic insulator for cracks, and if necessary, replace the igniter. After each inspection of the igniter, replace gasket and apply anti-seize compound to mounting screws prior to reinstalling them.
5. Ensure that igniter electrode spacing is within 1/8 inch.
6. When reinstalling the igniter after inspecting it, make sure there is a 3/8 inch gap between the igniter and the burner surface.

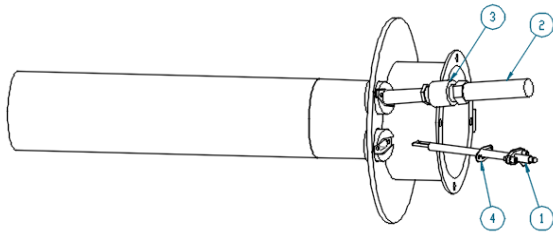

Figure 7: Ignition Assembly

- 1. Igniter
- 2. Ultra-Violet (UV) Scanner
- 3. ½" Heat Insulator
- Igniter Gasket

3. Be careful not to damage or disturb the insulation inside of the heat exchanger.

5.3 Burner Assembly Cleaning

1. After disconnecting power to the boiler, remove the boiler's furnace door. For part identification, refer to the "Repair Parts" section of this manual.
2. Clean around the burner assembly by blowing compressed air over the surface of the burner to remove lint and debris accumulation. Be careful when cleaning the burner assembly, to avoid damaging the metal mesh burner surface.
3. If the burner or the burner gasket shows any visual deterioration or corrosion signs, replace it immediately.
4. After replacing the burner or burner gaskets, check for proper operation by performing combustion analysis, as well as checking for gas leakage around the burner mounting and blower transition pieces.

5.4 Heat Exchanger Cleaning

1. Perform visual inspection of both boiler flue passes, and remove any debris from the surfaces of the heat exchanger.
2. If necessary, brush the tubes of the heat exchanger using non-abrasive, non-metallic bristle brush.

5.5 Tube Replacement Procedure

NOTICE

Performing a regular boiler inspection will prolong the life of the heat exchanger, and ensure optimal function and energy efficiency. For best practices, adhere to the general guidelines outlined in the service and maintenance section of this manual.

1. Inspect the boiler. Use the following steps to identify a potential tube leak and to minimize possible damage to the boiler and other equipment as a result of tube failures:
 1. Shut off power to the boiler immediately from the external, dedicated electrical disconnect.
 2. Confirm that any water leakage is not the result of a blocked condensate drain line.
 3. Remove the boiler's left side jacket panels and flue collector access panels as shown in Figure 8.
 4. Visually inspect the burner and furnace pass insulation for water damage. If significant water damage to the insulation or burner is observed, contact the manufacturer.
 5. Identify any leaking tubes.
 6. Isolate and drain the boiler completely.
2. Use the proper tools. Use the following tools to remove and replace leaking boiler tubes:
 1. Tube Puller (P/N 106019-02)
 2. Tube Driver (P/N 106019-01)
 3. Sledgehammer (steel head, approximately 3 lb)

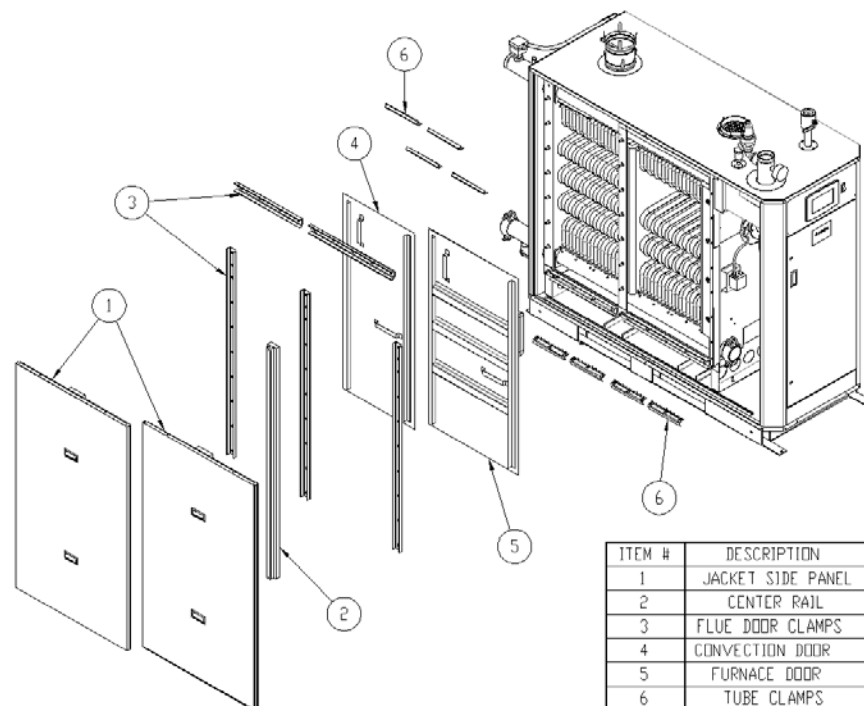

Figure 8: Panel Removal in Preparation for Tube Inspection

3. Loosen tube-ends. Insert tube puller between the tube-end and header. Apply pressure to the puller and strike the side of the tube two or three times with a hammer to help loosen the tube-end in the upper and lower header.
4. Pull lower tube end. Wedge the tube puller under the flange of the tube. Drive the tube puller with several blows with a hammer on the end of the handle. Alternate with downward blows to lift tube-end.
5. Clear tube-end from the header. Continue driving wedge under and leveraging flange up until it pops the end of the tube free from the hole in the header.
6. Pull upper tube-end. Repeat the procedure to the pull the tube-end of the same tube from the upper header.

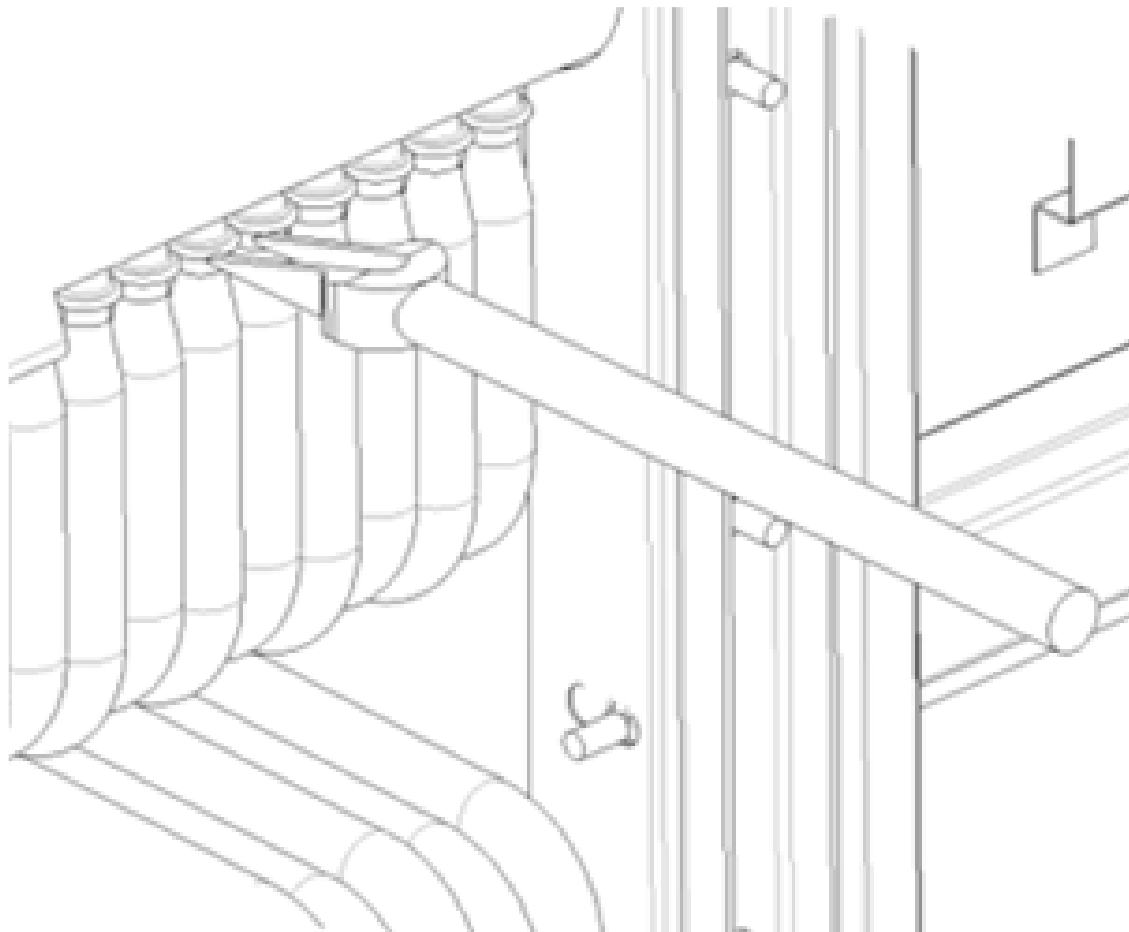

Figure 9: Tube Puller Insertion

7. Prepare the headers and replacement tubes. Before placing a new tube into the header, clean the holes by wiping gently with emery cloth to be sure that there are no burrs. Clean the replacement tube-ends of any rust or debris. With a small brush, apply a thin coating of gray pipe dope around the inside of the hole. Pipe dope may also be applied to the tube-end. Cutting oil may be mixed with the pipe dope for easier application.

8. Insert both ends of the tubes into the headers. Insert the lower tube-end into the bottom header first. Then insert the top tube-end into the top header. Insert all replacement tubes before driving them.
9. Drive the upper and lower tube-ends. DO NOT drive the tube-ends down to the flange. With the driver tool positioned on the flange, strike the end of the driver with hammer. After a few hits, the feel of the strike will become solid. The tone will also change from a “ting” sound to more of a “tong” sound. This indicates the tube has seated.

CAUTION

Do Not Overdrive Tubes! Overdriving tubes can cause damage to the tubes and boiler header holes. Use only approved Thermal Solutions tube driver and specified hammer. The end-formed tube fitting is designed to deform if overdriven to minimize damage to the vessel tube holes.

10. Reinstall the tube clamps. Replace the nuts and flat washers if damaged in any way. Use brass nuts only! Tighten the nuts until snug. Do not try to compress the tube-ends into the holes with the clamps, because the clamps might break or the stud might shear.
11. Refill the boiler. Fill the unit with water and ensure that there is no leakage at the replacement tube-ends before reinstalling the flue collector panels.

WARNING

If a leak is detected after a replacement tube has been installed, pressure in the boiler must be reduced to zero before adjusting tube(s). Adjusting tubes under pressure could result in serious personal injury.

12. Reinstall all flue access doors, door clamps, and jacket panels.
13. Perform startup check prior to putting boiler back into operation.

5.6 Safety and Operating Controls

All of the safety control devices listed in Table 15 are logically linked to the Concert Boiler Control that supervises the sequence of operation of the boiler for safe and efficient operation. It does so by ensuring proper light off and firing of the main burner and if need be, will immediately cut-off gas supply to the main burner when gas pressure, water temperature, water flow or another critical attribute is outside of the operational settings. It also varies the combustion rate in real time to meet the desired load of the system.

WARNING

Do not install, operate, service or repair any components of this equipment unless you are qualified and fully understand all requirements and procedures. Trained personnel should refer to those who have completed Thermal Solutions Service School training specific to this product.

Table 15: Safety and Operating Controls

Component	Function
Power Switch	If this switch is in the off position, power is interrupted to the control circuit of the boiler, which prevents the boiler from operating. If the switch is in the on position, power is supplied to the control circuit.
Automatic Reset Operating Aquastat	If the boiler water temperature exceeds the adjustable set point, power is interrupted to the control circuit of the boiler, which prevents the boiler from operating. When the boiler water temperature drops below the set point minus the adjustable differential setting, power is again supplied to the control circuit.
Manual Reset High Limit Aquastat	If the boiler water temperature exceeds the adjustable set point, power is interrupted to the control circuit of the boiler, which prevents the boiler from operating. Power is interrupted until the control is manually reset pressing the control's reset button. When the button is pressed, power will again be supplied to the control circuit, assuming that the boiler water temperature has dropped below the setpoint minus the differential setting.
Water Flow Switch	If the water flow through the boiler drops below the fixed flow rate required to move the control's paddle enough to close the control's contacts, power is interrupted to the control circuit, which prevents the boiler from operating. When the water flow rate increased, the paddle closes the control's contacts and power is supplied to the control circuit.
Pressure / Safety Relief Valve	If the pressure inside the boiler exceeds the fixed set point, the valve opens mechanically and discharges water. The valve remains open until the pressure inside the boiler drops below the set point.
High and Low Gas Pressure Switches	If the gas pressure reaches a point above or below the adjustable set point, the contacts of the switch open and power is interrupted to the control circuit that prevents the boiler from operating. Power is interrupted until gas pressure is between the high and low gas pressure set points and the control is manually reset moving the switch to the reset position. The switches will not reset until the gas pressure is within the set point parameters.
Minimum Air Pressure Switch	If the differential air pressure drops below the fixed set point, the contacts of the switch open and power is interrupted to the control circuit, which prevents the boiler from operating. Power is interrupted until air flow/pressure increases so that contacts close.

Maximum Air Pressure Switch	If the differential air pressure exceeds the fixed set point, the contacts of the switch open and power is interrupted to the control circuit, which prevents the boiler from operating. Power is interrupted until air flow/pressure decreases below the setting so that the contacts close.
-----------------------------	---

5.7 Troubleshooting

Refer to the troubleshooting section in the Concert Boiler Control manual on how to navigate the Limit String Status screen that shows an active safety limit status and for an in-depth guide to all the possible lockouts as well as recommended corrective actions for restore boiler operation.

INDICATION	POSSIBLE CAUSE	CORRECTIVE ACTION
Boiler is not responding to a call for heat, "Status" and "Priority" show "Standby".	Boiler is not seeing Enable/Disable of Domestic Demand Input.	Check wiring for loose connections or wiring errors. If Domestic Demand is expected check the DHW Demand/Modulation is selected properly.
Boiler is not responding to call for heat, "Status" shows "Standby" and "Priority" shows Central Heat or Domestic Hot Water.	Boiler is not firing, or temperature is greater than setpoint.	Select display Help icon and review Limit String Status.
Boiler is Running but System or Boiler Circulator is not running.	Pump Not Running.	<ol style="list-style-type: none"> 1. Check wiring for loose connections or wiring errors. 2. When there is a Domestic Hot Water Heat Request the System or Boiler Pump will be forced "off" when their "Run Pump for" parameter is set to "Central heat, off DHW demand" or "Central Heat, Optional Priority". This has been set to allow all of the heat to be provided for fast indirect water heater recovery. After "Priority protection" time or the end of the Domestic Hot Water Heat Request the system and boiler pumps will be free to run.

Table 16: General Troubleshooting

INDICATION	POSSIBLE CAUSE	CORRECTIVE ACTION
Display Completely Dark Fun off, LWCO lights off, no green power light on Control.	No 120 Vac Power at Boiler due to blown high voltage fuse or circuit breaker trip.	<ol style="list-style-type: none"> 1. Check breaker and wiring between breaker and boiler. 2. Replace blown high voltage fuse. 3. Reset tripped breaker.
Display Completely Dar, Fun running.	No 120 Vac Power at Control; No 24 Vdc to Display.	<ol style="list-style-type: none"> 4. Check loose 120 Vac connection wiring between boiler J-Box and transformer or 24 Vdc power supply. 5. Check for loose 24 Vac connection wiring between transformer and Control. 6. Check blown low voltage fuse: Replace in necessary. 7. Check for bad transformer or bad 24 Vdc power supply: Replace if necessary.
Blinking Green power light on Control.	Control Fault.	The green light is connected to internal power supply. The power supply is repeatedly starting and stopping (not normal) making the light flash. The microprocessors are not running. Try disconnecting all terminals except 24 Vac to power the control. The green light should be steady. If it is not, then the control is defective. If steady, start plugging in all the connectors while watching the green light. When the faulty wiring reconnected, green light will begin to flash.
Blank Screen with “Reading” shown.	Display lost communication with Control.	Failure to establish Communication upon boot-up once you establish communication, reboot display to read controller and setup display properly.
Communication Error 2.	Un-configured control, or control has a memory failure.	The display-write attempt has failed. The controller is un-configured or has a memory failure. Lockout 20 Safety Data Verification will also be displayed. Replace Control.
Communication Error 3.	Communication Fault.	<p>Display has lost communication with controller.</p> <ol style="list-style-type: none"> 1. Check for loose or defective display harness, defective display or defective control. 2. Refer to Concert Boiler Control manual for more details.

Table 16: General Troubleshooting

INDICATION	POSSIBLE CAUSE	CORRECTIVE ACTION
Short Cycling	Oversized Boiler	6.Examine system and boiler operational settings to determine what adjustments may be made to reduce boiler cycling. 7.Contact Manufacturer.
Poor Combustion	Incorrect Gas Valve Settings	If combustion is too lean or rich as a result of improper gas valve settings, adjust air-fuel ratio to match factory O2 settings.
	Dirty Heat Exchanger	Inspect heat exchanger tubes for damage and carbon build-up. Inspect and clean the burner assembly. Refer to the Service, Maintenance and Inspection section of the manual for guidance.
	Leakage	Remove the boiler's side panels and check for flue gas leakage around the heat exchanger, burner mounting plate, and blower transition piece.

Appendix A Sizing Gas Piping

Design the gas piping system to provide an adequate gas supply to the boiler. Refer to Table 4 for minimum and maximum gas supply pressures and boiler capacities. Also consider existing and expected future gas utilizing equipment (i.e., water heater, cooling equipment). Refer to Table 17 for maximum capacity of schedule 40 pipe. Table 18 lists equivalent pipe length for standard fittings. Given the specific gravity of gas at the boiler's location, a correction factor can be found on Table 19 and multiplied by the "Capacity in Cubic Feet of Gas Per Hour" on Table 17. For gas piping material other than schedule 40 pipes, refer to the National Fuel Gas Code, NFPA 54/ANSI Z223.1 and/or CAN/CGA B149 Installation codes. Use methods and materials in accordance with Local Codes and requirements of gas supplier. In the absence of such requirement follow National Fuel Gas Codes, NFPA /ANSI Z 223.1 and/or CAN/CGA B149 Installation Codes.

Table 17: Maximum Gas Capacity Of Schedule 40 Pipe

Pipe Length in Equivalent Feet	Pipe Size (nps)							
	¾	1	1-1/4	1-1/2	2	2-1/2	3	4
10	273	514	1060	1580	3050	4860	8580	17500
20	188	353	726	1090	2090	3340	5900	12000
30	151	284	583	873	1680	2680	4740	9660
40	129	243	499	747	1440	2290	4050	8270
50	114	215	442	662	1280	2030	3590	7330
60	104	195	400	600	1160	1840	3260	6640
70	95	179	368	552	1060	1690	3000	6110
80	89	167	343	514	989	1580	2790	5680
90	83	157	322	482	928	1480	2610	5330
100	79	148	304	455	877	1400	2470	5040
125	70	131	269	403	777	1240	2190	4460
150	63	119	244	366	704	1120	1980	4050
175	58	109	224	336	648	1030	1820	3720
200	54	102	209	313	602	960	1700	3460

Based on gas pressures less than 2 psig and a pressure drop of 3.0 iwc and 0.6 specific gravity.

Table 18: Equivalent Lengths Of Standard Pipe Fittings And Valves

Pipe Size (nps)	ID (in.)	Valves Fully Open (Screwed, Flanged, Welded)				Schedule 40, Screwed Fittings		
		Gate	Globe	Angle	Swing Check	90 deg. Elbow (threaded)	45 deg. Elbow (threaded)	90 deg. Tee, Flow Through Branch (threaded)
1/2	.622	.36	17.3	8.65	4.32	1.55	.73	3.1
3/4	.824	.48	22.9	11.4	5.72	2.06	.96	4.12
1	1.049	.61	29.1	14.6	7.27	2.62	1.22	5.24
1-1/4	1.38	.81	38.3	19.1	9.58	3.45	1.61	6.9
1-1/2	1.61	.94	44.7	22.4	11.2	4.02	1.88	8.04
2	2.067	1.21	57.4	28.7	14.4	5.17	2.41	10.3
2-1/2	2.469	1.44	68.5	34.36	17.1	6.16	2.88	12.3

3	3.068	1.79	85.2	42.6	21.3	7.67	3.58	15.3
4	4.026	2.35	112	56	28	10.1	4.7	20.2
6	6.065	3.54	168	84.1	42.1	15.2	7.07	30.4
Equivalent lengths are for standard screwed fittings and for screwed, flanged, and welded valves relative to schedule 40 steel.								

Specific Gravity	Correction Factor	Specific Gravity	Correction Factor
.5	1.1	1.2	.71
.55	1.04	1.3	.68
.6	1.0	1.4	.66
.65	.96	Propane	
.7	.93	1.5	.63
.75	.9	1.6	.61
.8	.87	1.7	.59
.85	.84	1.8	.58
.9	.82	1.9	.56
1.0	.78	Butane	
1.1	.74	2.0	.55

Appendix B Vent and Combustion Air Pressure Drop Data

The combined pressure drop through the vent and combustion air duct shall not exceed 100 equivalent feet. Use the tables below to calculate the pressure drop in the vent / combustion air system.

ARC1000 Pressure Drop in Equivalent Feet (Flue Vent)				
Flue Vent Diameter (in.)	Straight Length (eq ft/ft)	90° Elbow (eq ft)	45° Elbow (eq ft)	Velocity (fpm)
6	1	10	5	1534
8	.22	2.22	1.11	863
ARC1500 Pressure Drop in Equivalent Feet (Flue Vent)				
8	.56	5.88	2.86	1296
10	.174	1.75	.87	829
ARC2000 Pressure Drop in Equivalent Feet (Flue Vent)				
8	1	10	5	1728
10	.31	3.125	1.56	1106
12	.12	1.19	.59	768
ARC2500 Pressure Drop in Equivalent Feet (Flue Vent)				
8	1.563	16.67	8.33	2158
10	.478	5	2.44	1381
12	.183	1.852	.92	959
ARC3000 Pressure Drop in Equivalent Feet (Flue Vent)				
8	2.22	25	11.11	2591
10	.68	7.14	3.57	1650
12	.267	2.7	1.35	1152

ARC1000 Pressure Drop in Equivalent Feet (Combustion Air Duct)				
Air Duct Diameter (in.)	Straight Length (eq ft/ft)	90° Elbow (eq ft)	45° Elbow (eq ft)	Velocity (fpm)
6	.6	6.25	3.13	1121
8	.13	1.32	.658	631
ARC1500 Pressure Drop in Equivalent Feet (Combustion Air Duct)				
8	.3	3.03	1.49	946
10	.09	.92	.46	605

ARC2000 Pressure Drop in Equivalent Feet (Combustion Air Duct)				
8	.53	5.26	2.63	1264
10	.164	1.64	.82	809
12	.063	.63	.314	562
ARC2500 Pressure Drop in Equivalent Feet (Combustion Air Duct)				
8	.83	8.3	4.17	1576
10	.26	2.56	1.28	1009
12	.1	.98	.49	701
ARC3000 Pressure Drop in Equivalent Feet (Combustion Air Duct)				
8	1.19	12.5	5.9	1895
10	.37	3.7	1.85	1213
12	.14	1.41	.7	842

Appendix C Venting Diagrams

Appendix C.1 Typical Horizontal Vent Piping

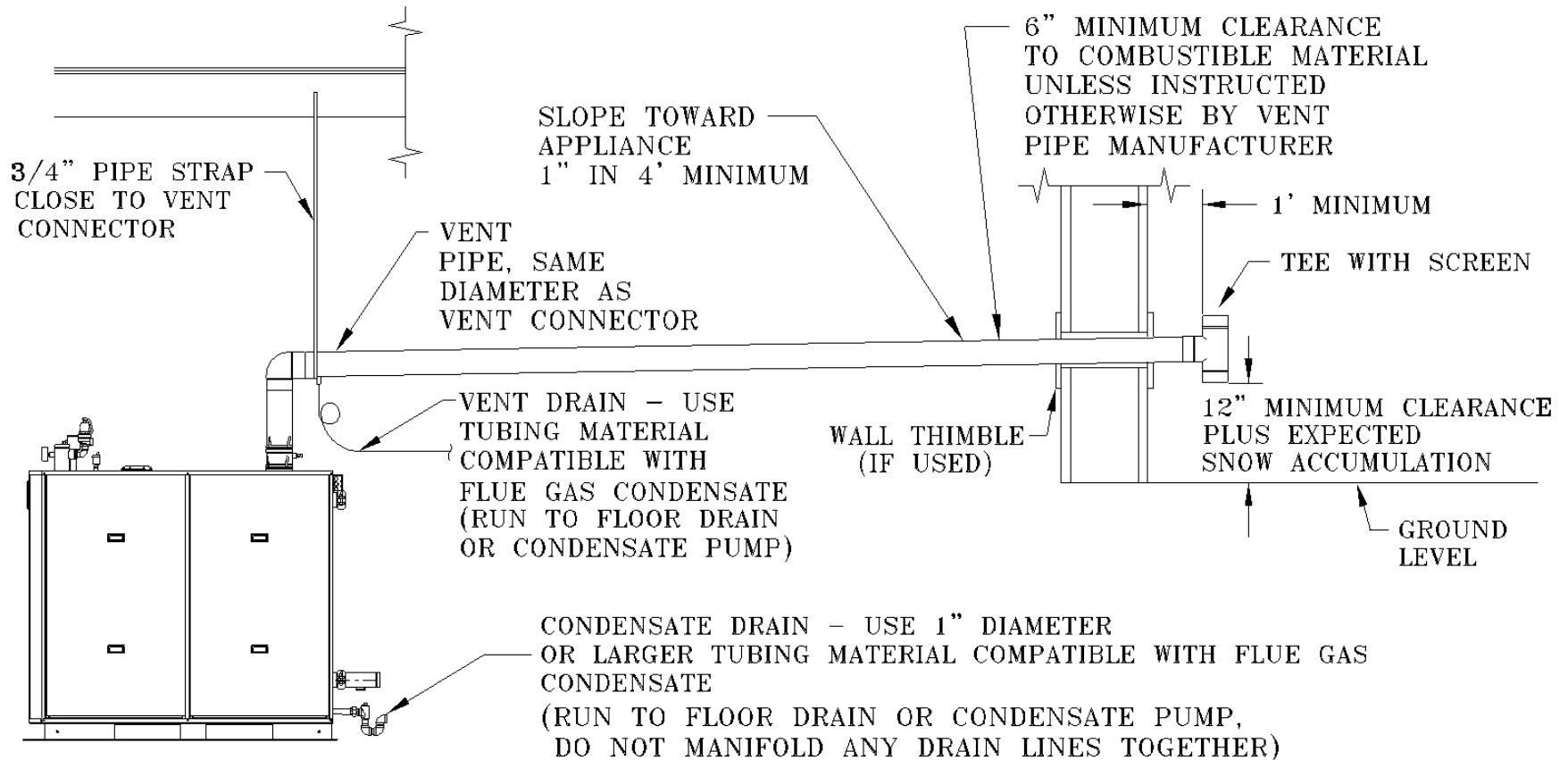

Appendix C.2 Typical Vertical Pressurized Venting

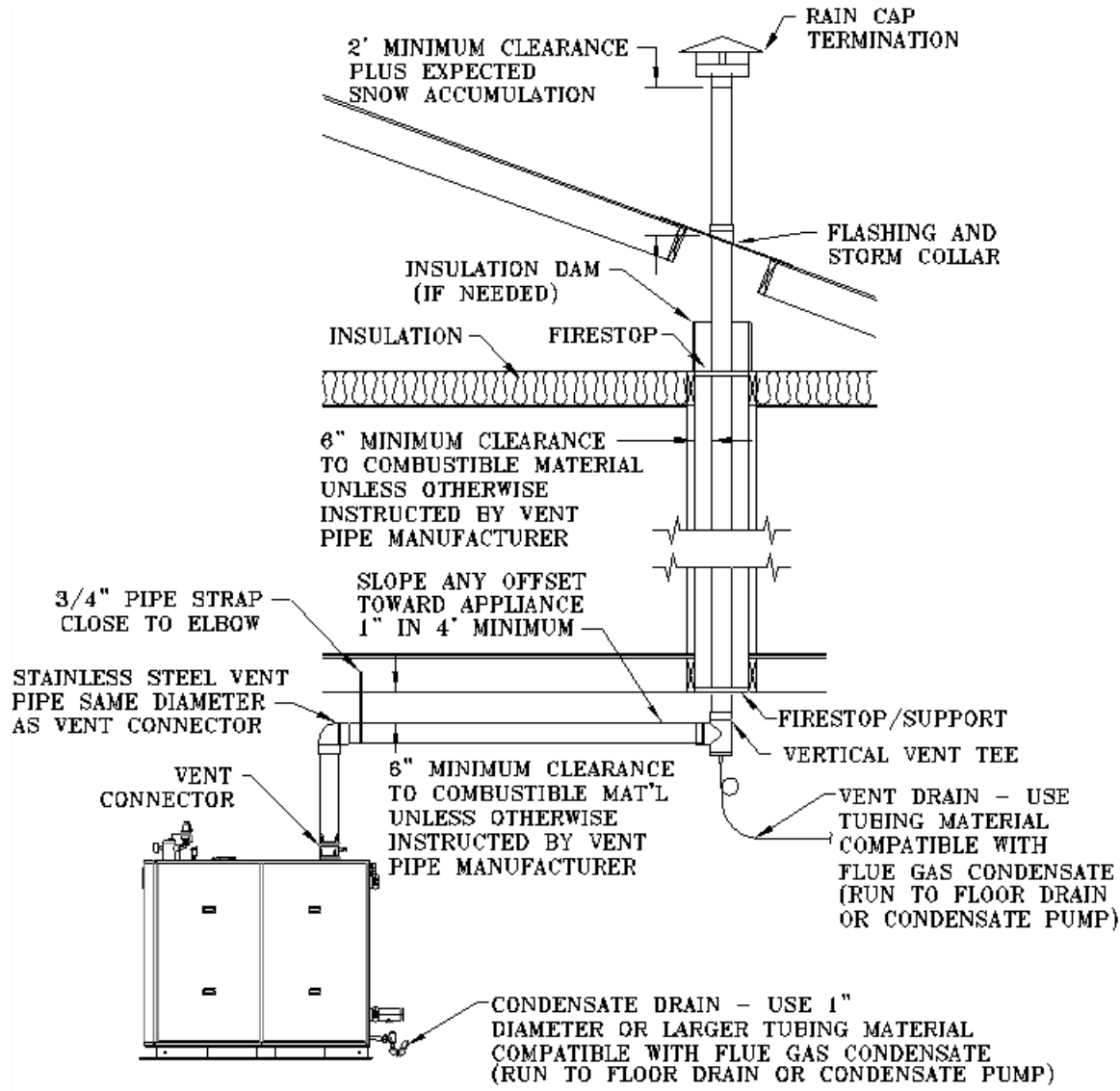

Appendix D Combustion Air Diagrams

Appendix D.1 Typical Horizontal Air Intake Piping

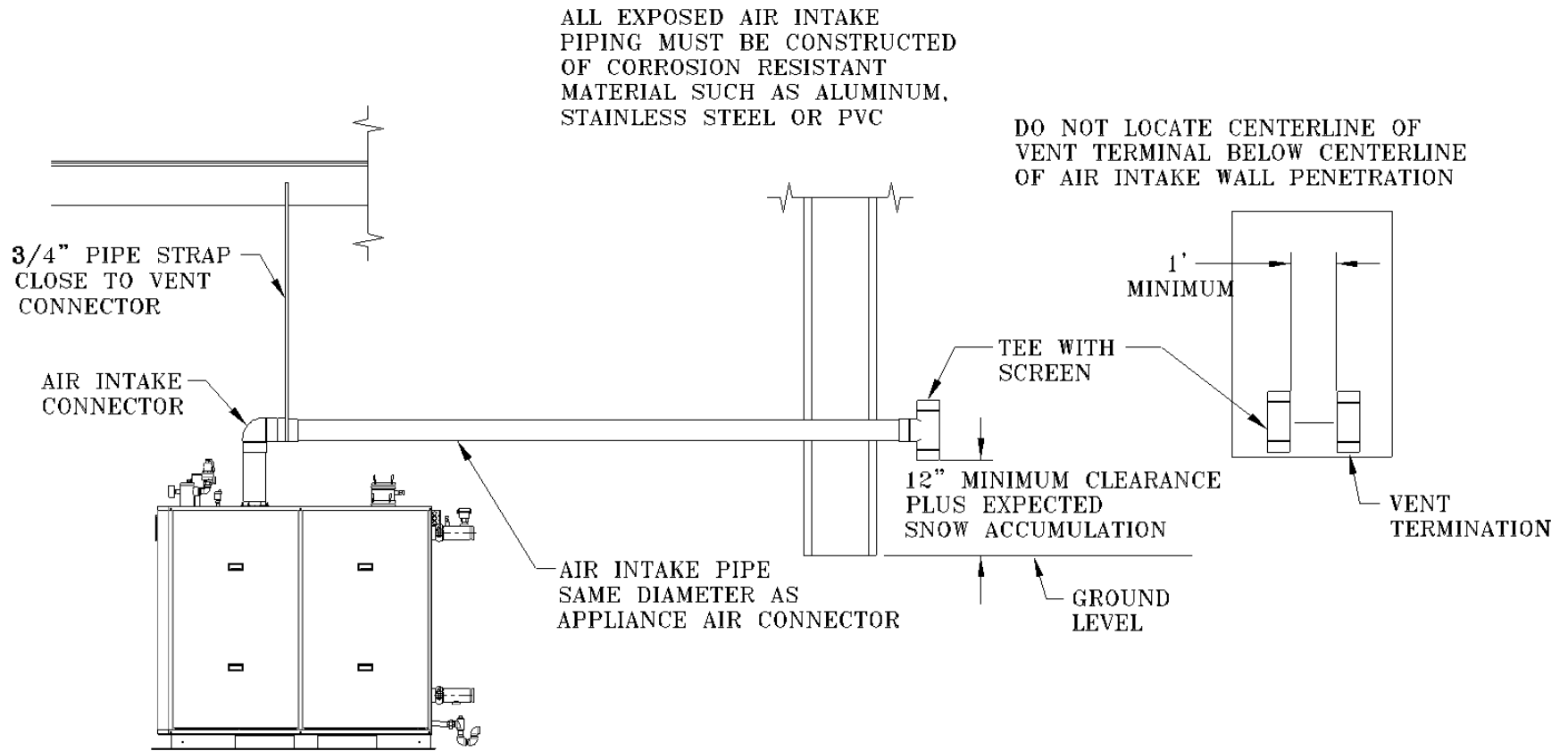

Appendix D.2 Typical Vertical Air Intake Piping

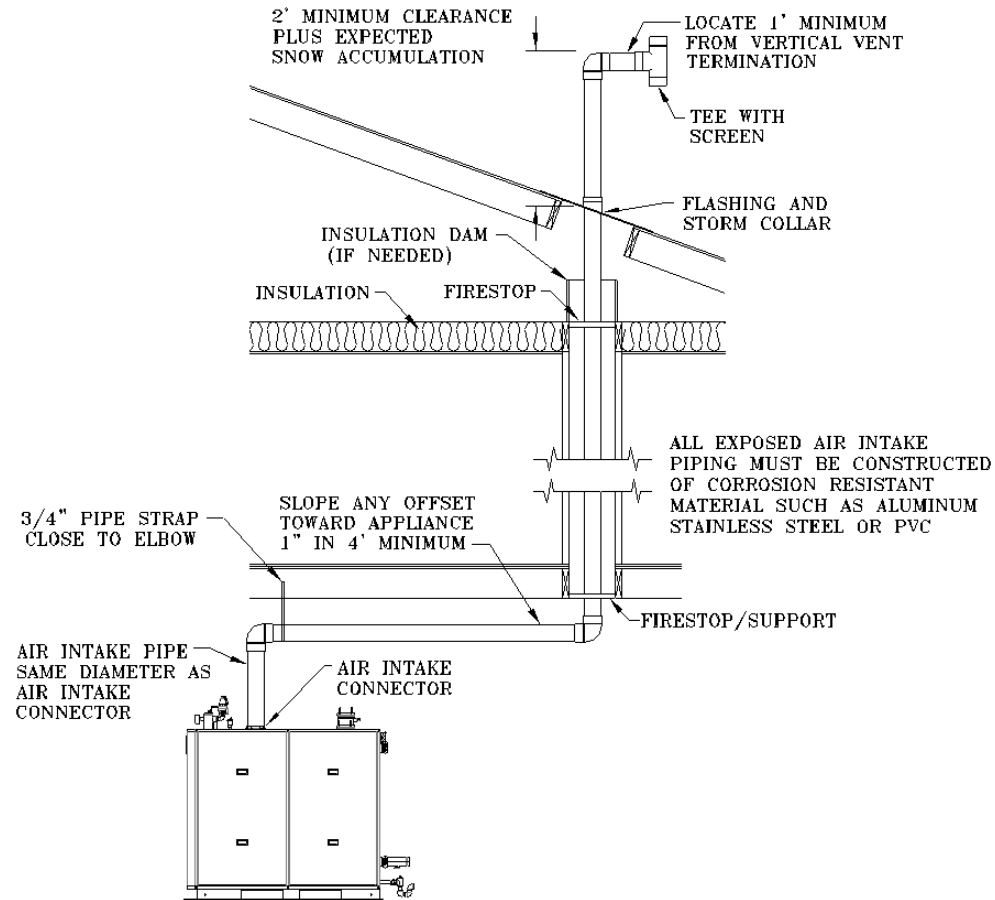

Appendix E Boiler Piping Diagrams

Appendix E.1 Single Boiler, Primary / Secondary

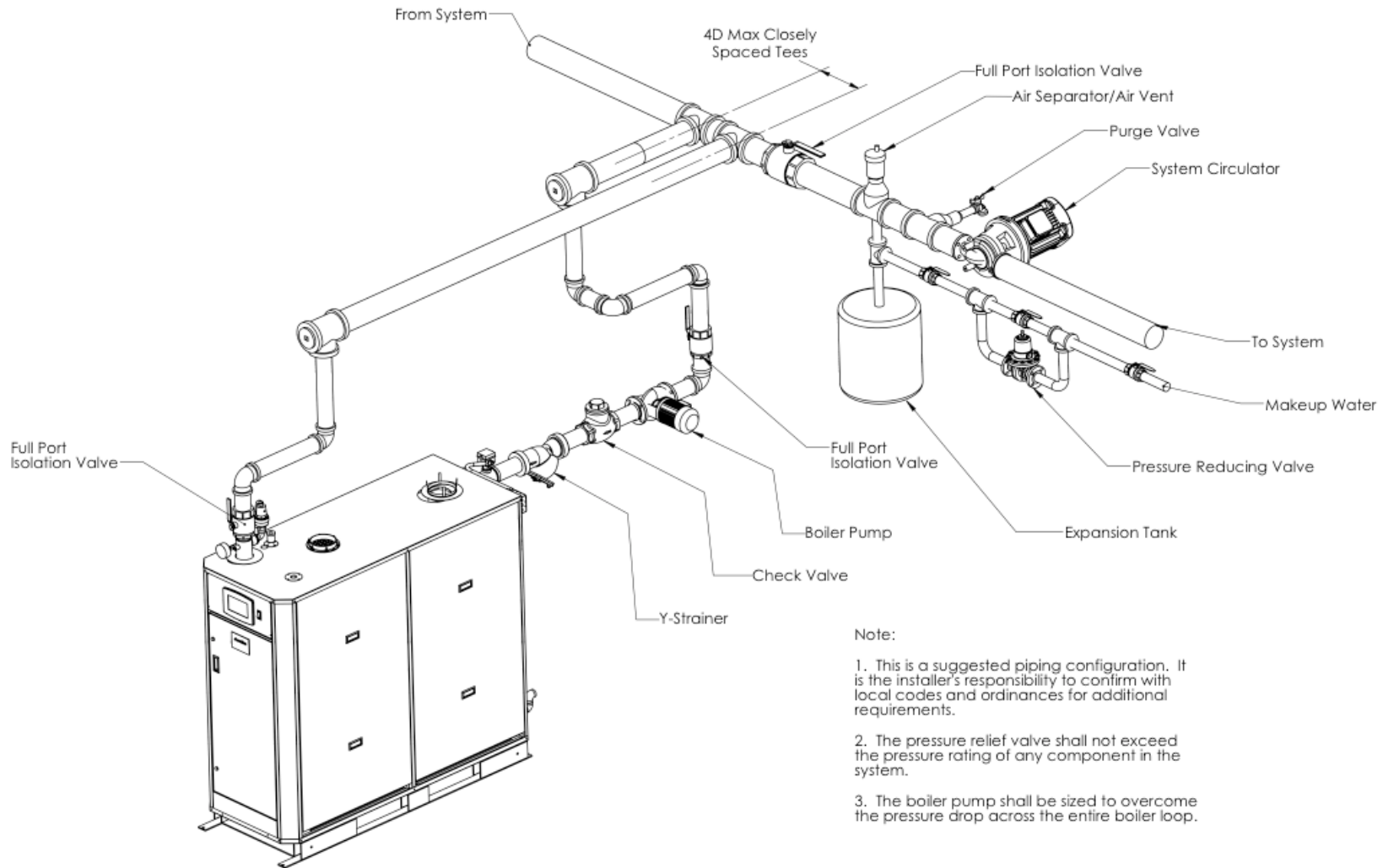

Appendix E.2 Multiple Boilers, Primary Reverse-Return Piping

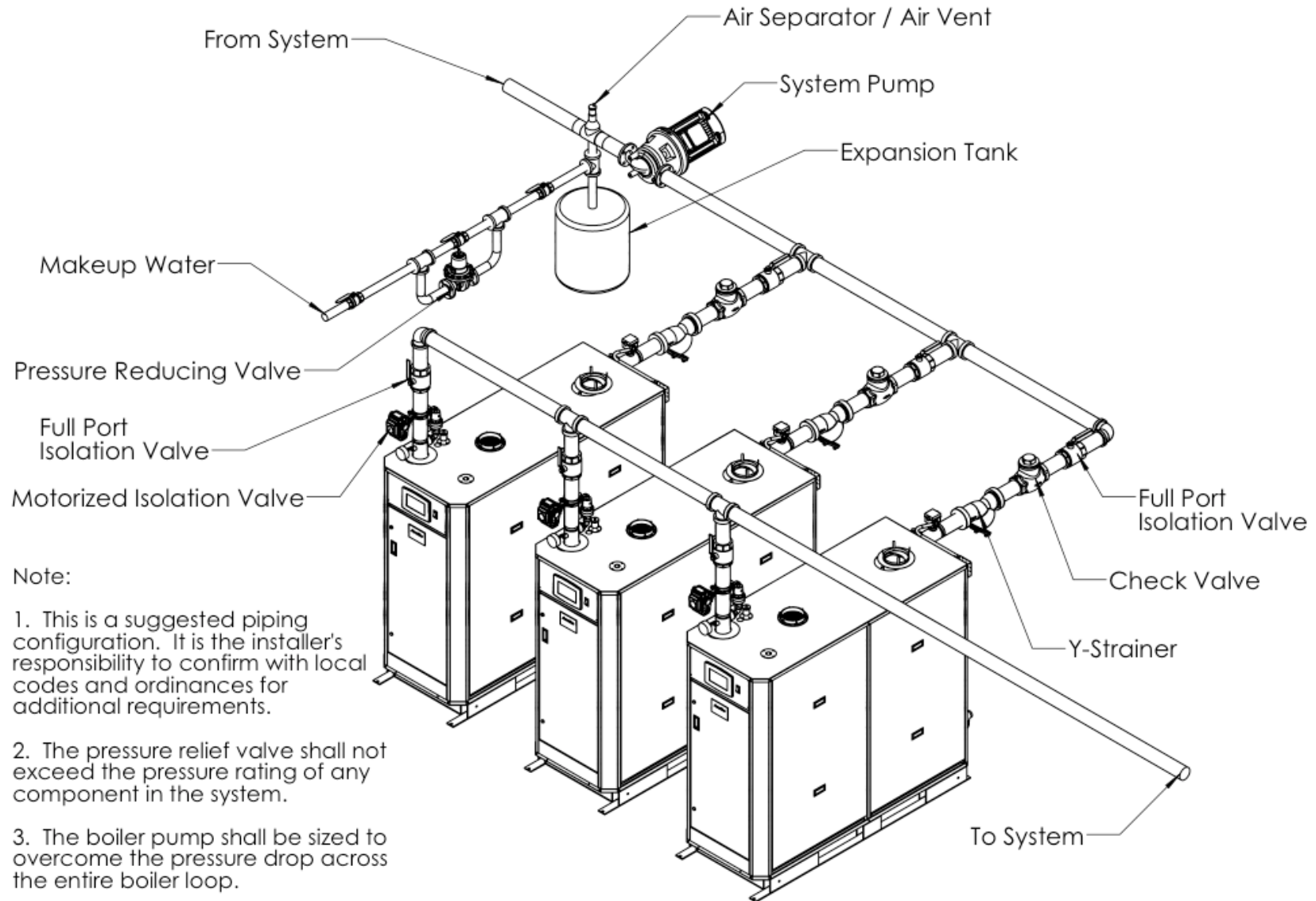

Appendix E.3 Multiple Boilers, Primary / Secondary Reverse Return Piping

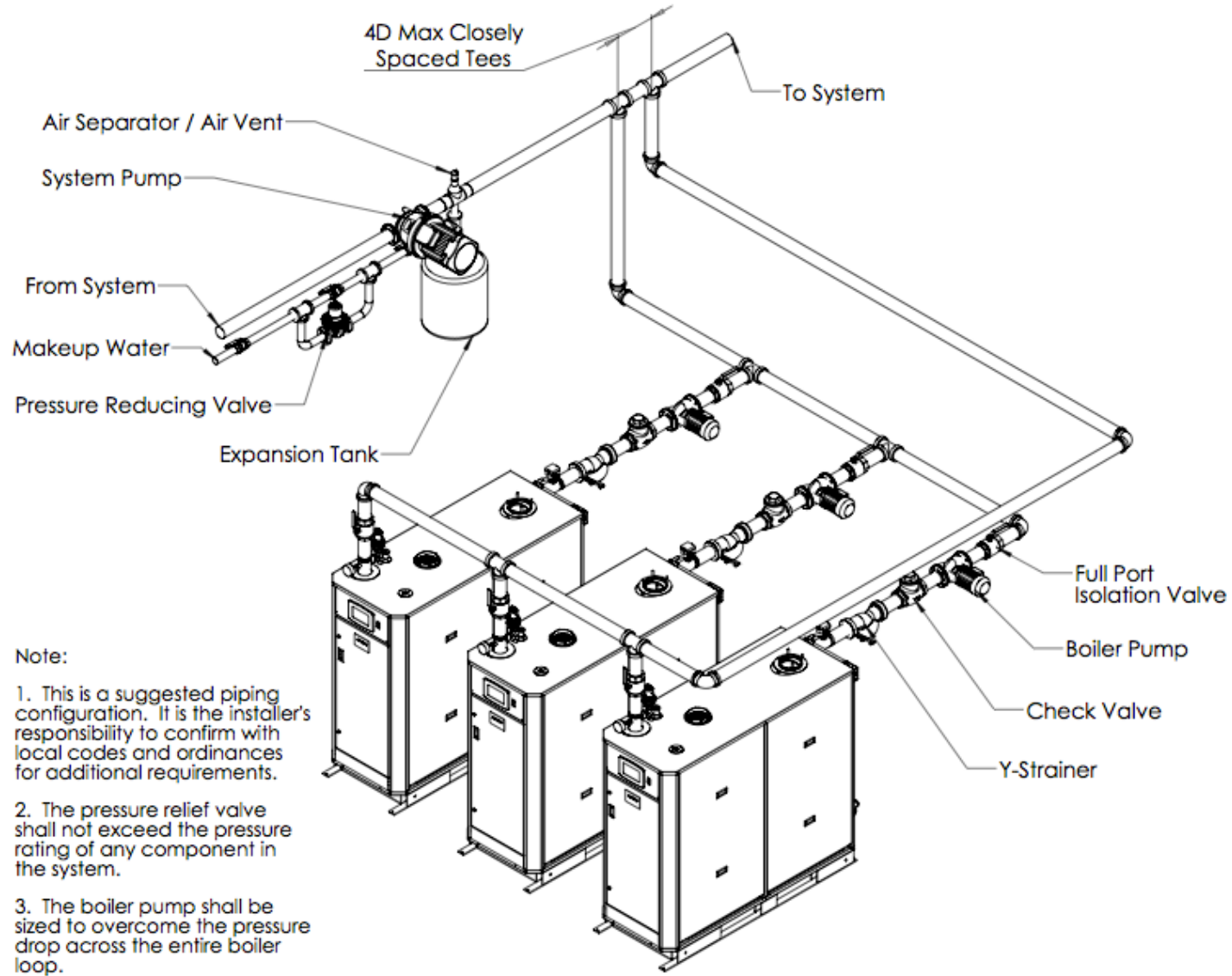

Appendix E.4 Multiple Boilers, Primary / Secondary Piping

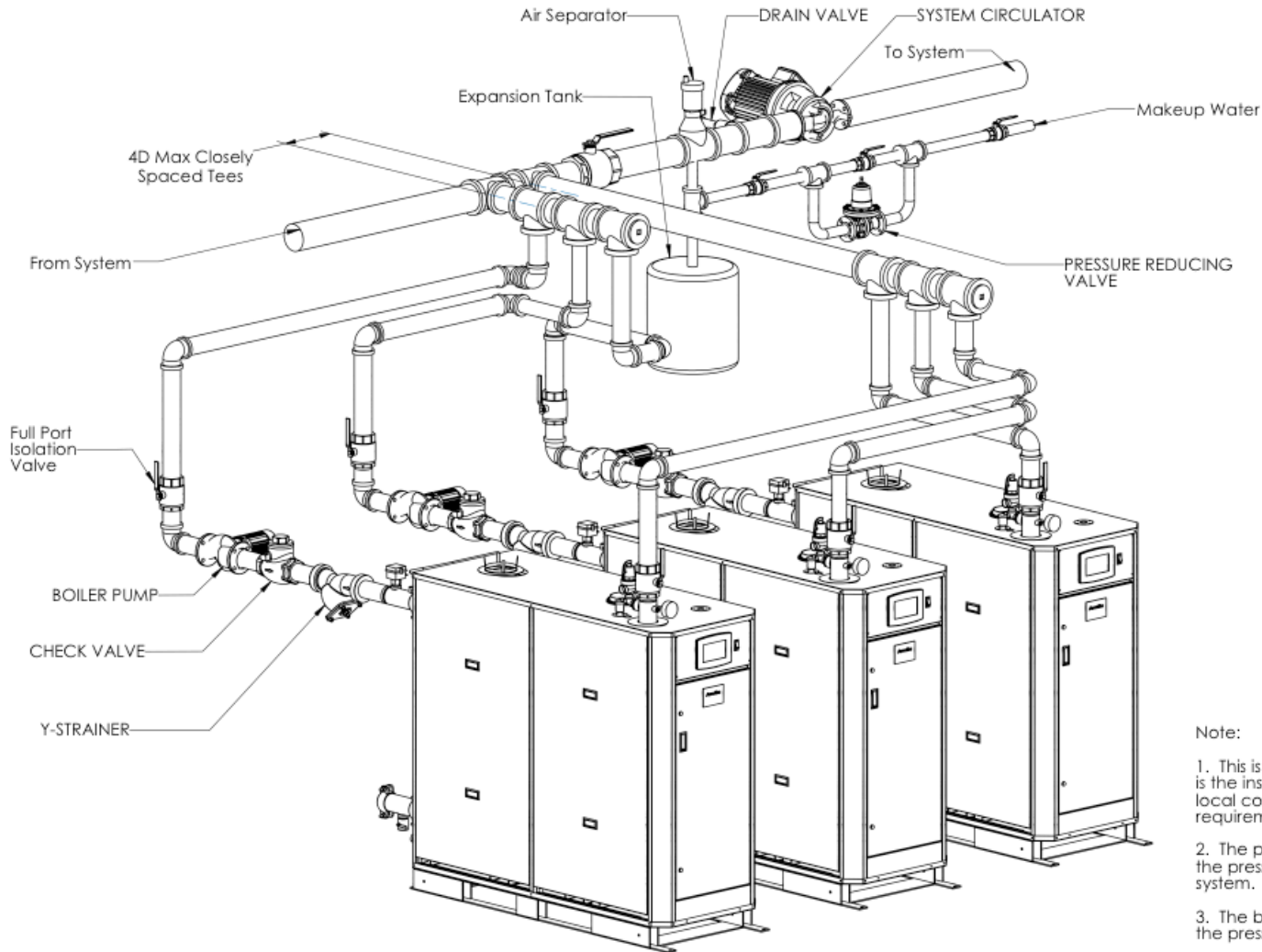

Note:

1. This is a suggested piping configuration. It is the installer's responsibility to confirm with local codes and ordinances for additional requirements.
2. The pressure relief valve shall not exceed the pressure rating of any component in the system.
3. The boiler pump shall be sized to overcome the pressure drop across the entire boiler loop.

Appendix E.5 Multiple Boilers, Primary / Secondary Piping, Heating with Domestic Hot Water

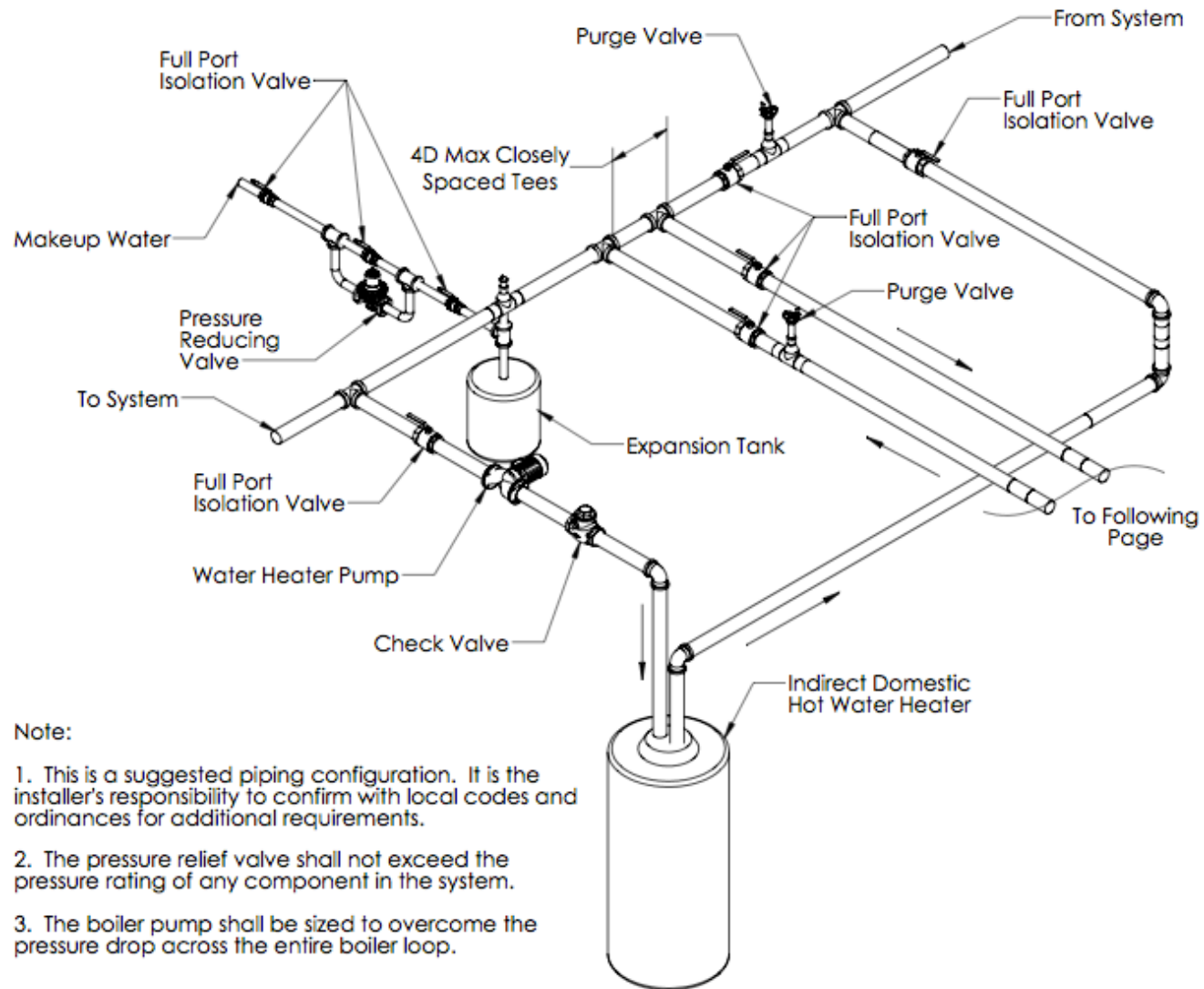

Note:

1. This is a suggested piping configuration. It is the installer's responsibility to confirm with local codes and ordinances for additional requirements.
2. The pressure relief valve shall not exceed the pressure rating of any component in the system.
3. The boiler pump shall be sized to overcome the pressure drop across the entire boiler loop.

Appendix E.6 Multiple Boilers, Primary / Secondary Piping, Heating with Domestic Hot Water (continued)

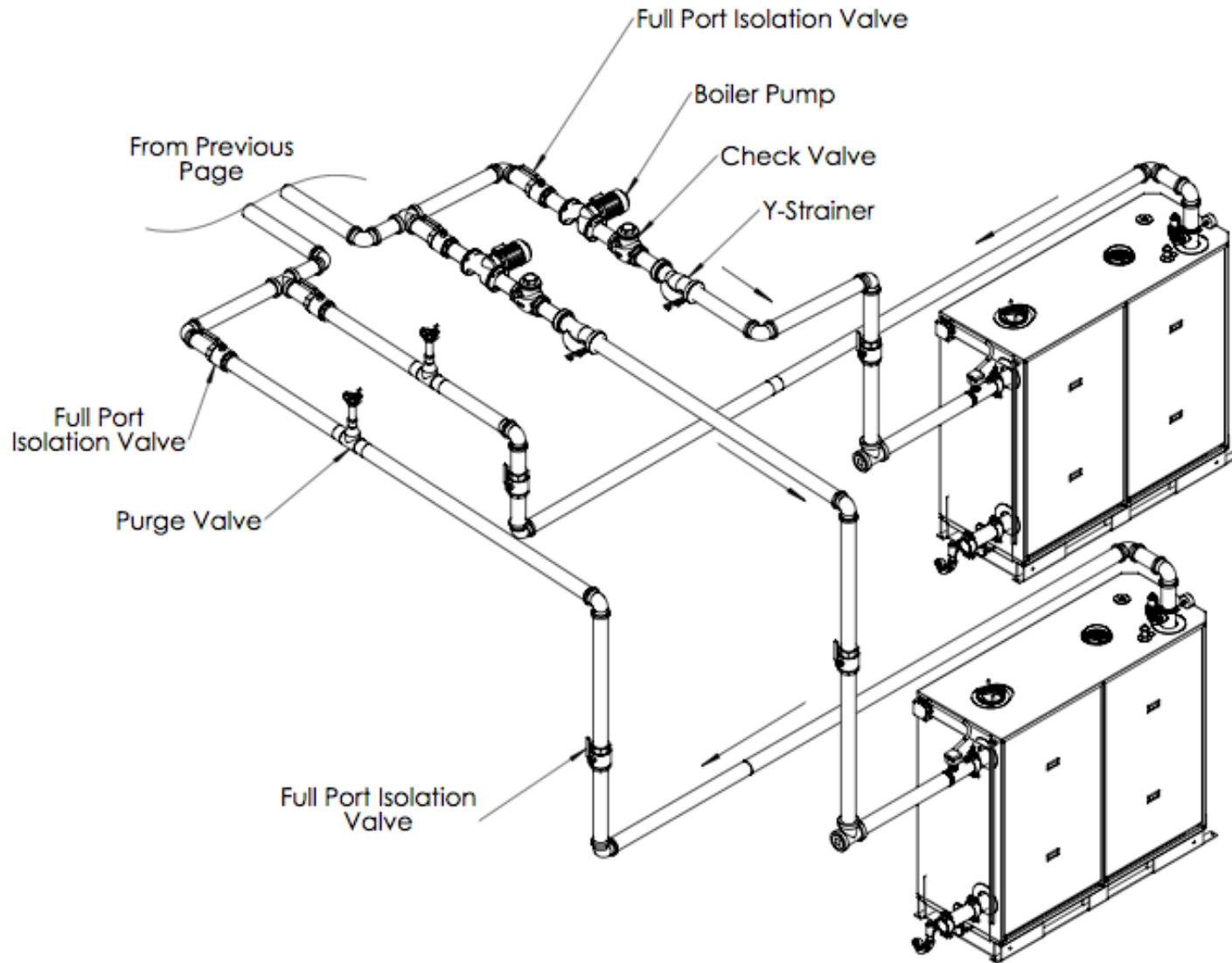

Appendix F Water Flow Pressure Drops

ARCTIC 1000			ARCTIC 1500			ARCTIC 2000		
Delta T	GPM	Ft. Hd.	Delta T	GPM	Ft. Hd.	Delta T	GPM	Ft. Hd.
100F	19	0.51	100F	29	0.37	100F	38	0.65
90F	21	0.63	90F	32	0.45	90F	42	0.80
80F	24	0.79	80F	36	0.58	80F	48	1.02
70F	27	1.04	70F	41	0.75	70F	54	1.33
60F	32	1.41	60F	48	1.02	60F	63	1.81
50F	38	2.03	50F	57	1.47	50F	76	2.61
45F	42	2.51	45F	63	1.82	45F	84	3.22
40F	48	3.18	40F	71	2.30	40F	95	4.08
35F	54	4.15	35F	81	3.00	35F	109	5.32
30F	63	5.64	30F	95	4.09	30F	127	7.24
25F	76	8.13	25F	114	5.89	25F	152	10.43
20F	95	12.70	20F	143	9.20	20F	190	16.30
ARCTIC 2500			ARCTIC 3000					
Delta T	GPM	Ft. Hd.	Delta T	GPM	Ft. Hd.			
100F	48	0.80	100F	57	1.15			
90F	53	0.99	90F	63	1.42			
80F	59	1.25	80F	71	1.79			
70F	68	1.63	70F	81	2.34			
60F	79	2.22	60F	95	3.19			
50F	95	3.20	50F	114	4.59			
45F	106	3.95	45F	127	5.67			
40F	119	5.00	40F	143	7.18			
35F	136	6.53	35F	163	9.37			
30F	158	8.89	30F	190	12.76			
25F	190	12.80	25F	228	18.37			
20F	238	20.00	20F	285	28.70			

Delta T's are based on the maximum output with a nominal boiler efficiency of 95%.

Appendix G Wiring Diagrams

Appendix G.1 ARC1000 Wiring Diagram

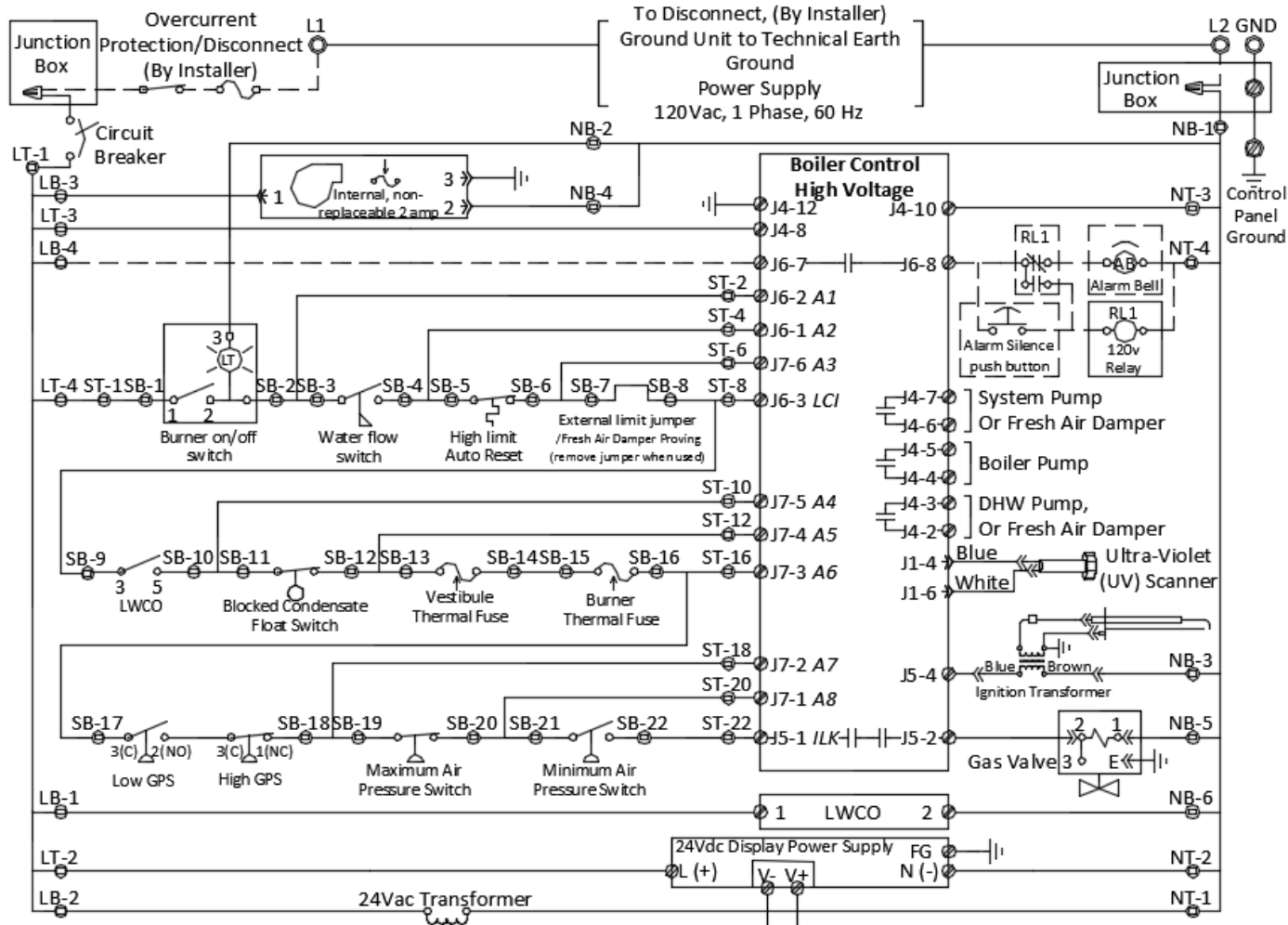

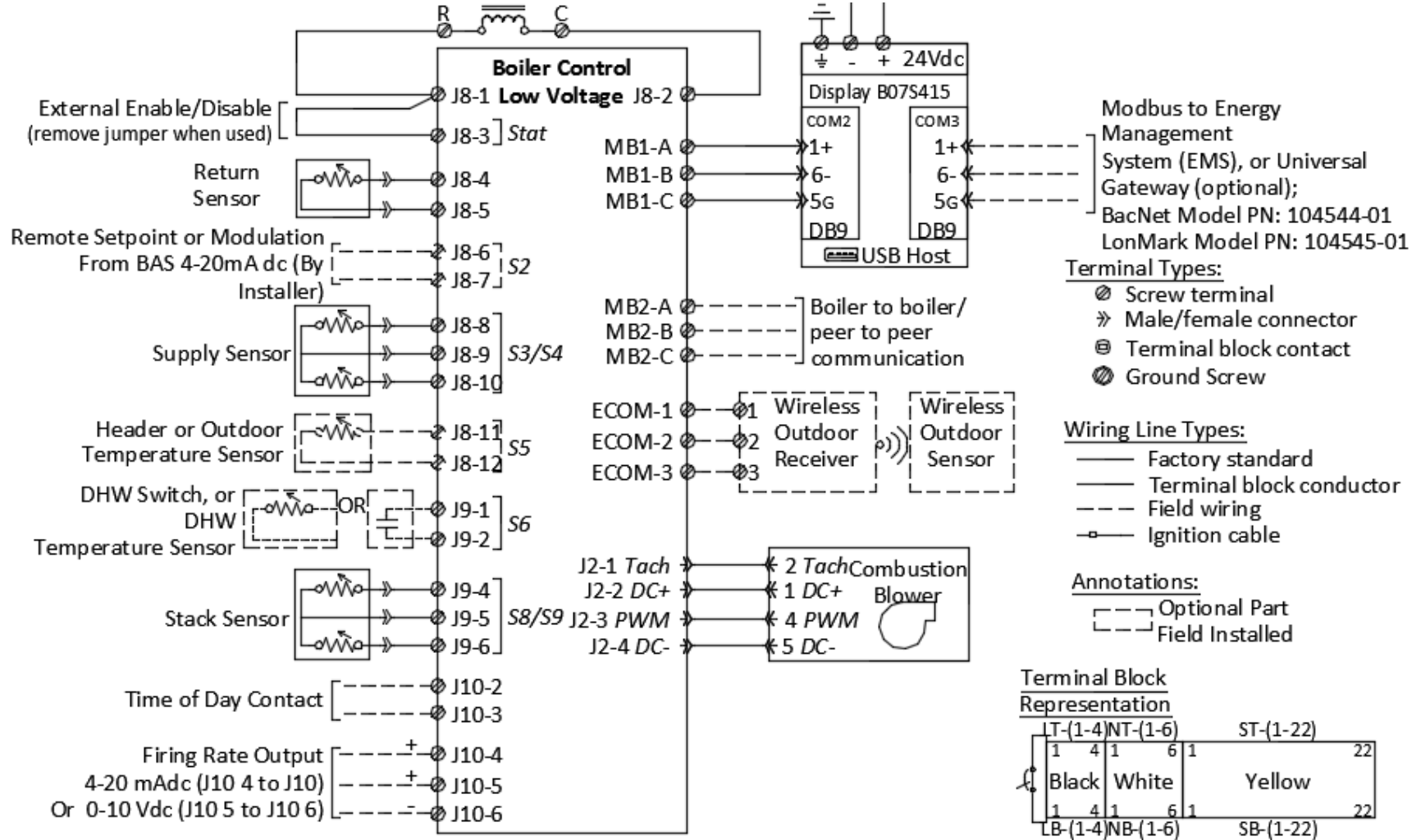

Appendix H Repair Parts

All boiler Repair Parts may be obtained through your local authorized Thermal Solutions Representative. Should you require assistance in locating a Thermal Solutions representative in your area, or have questions regarding the availability of Thermal Solutions products or repair parts, please contact Thermal Solutions Customer Service at (717)-239-7642 or Fax (877)-501-5212.

Appendix H.1 ARC1000 Heat Exchanger

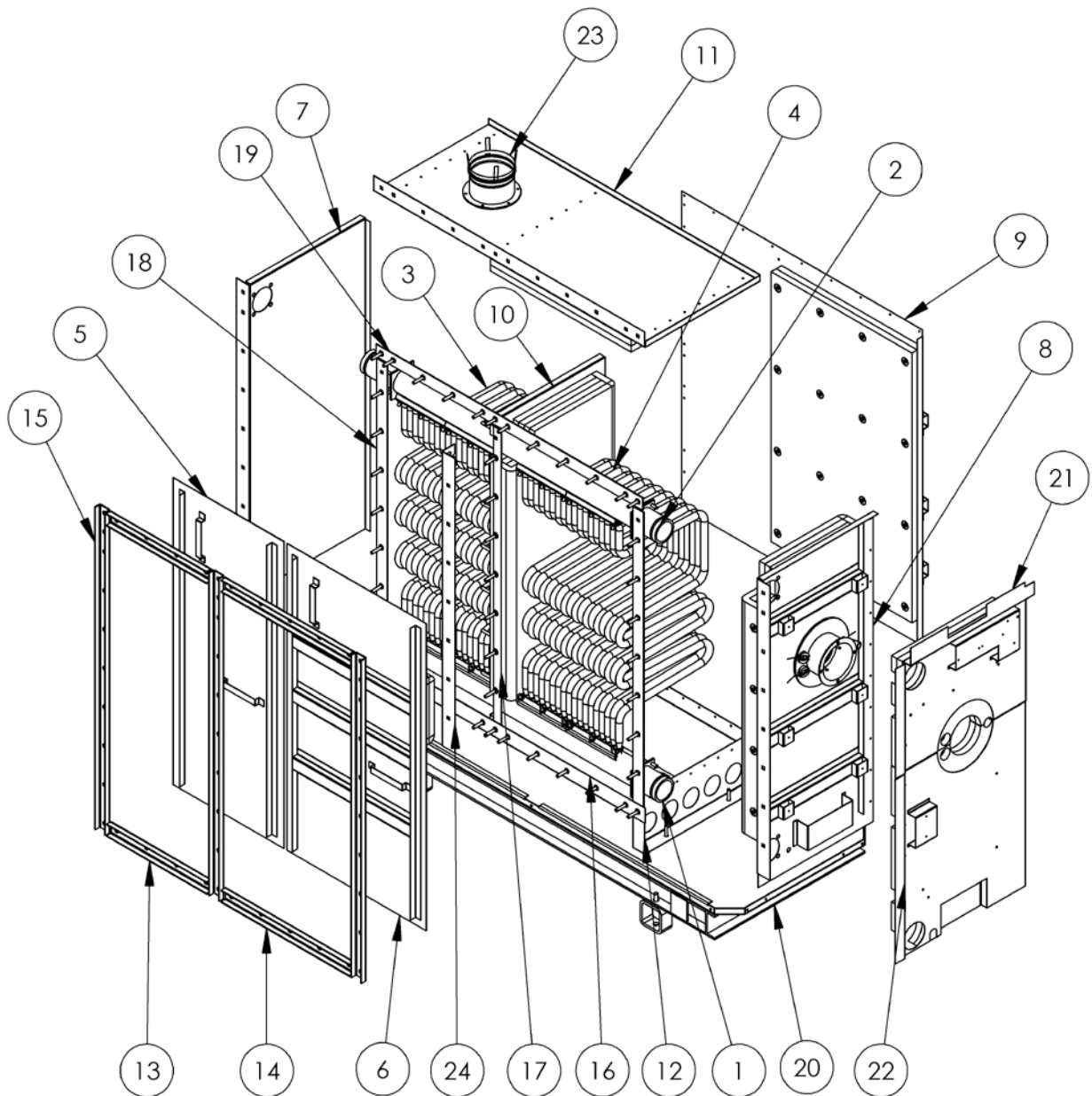

Table 20: Heat Exchanger Parts

Item Number	Description	Quantity	Part Number
1	Lower Header	1	105670-01
2	Upper Header	1	105669-01
3	Convection Tubes Long Return (Yellow Paint)	9	105696-01
	Convection Tubes Short Return (Black Paint)	9	105696-04
4	Furnace Tubes Long Return	9	105696-02
	Furnace Tubes Short Return	9	105696-03
5	Convection Tube Access Door	1	(1) 105276-06
6	Furnace Tube Access Door	1	(1) 105539-01
7	Flue Collector Rear Panel	1	(1) 105277-01
8	Flue Collector Front Panel	1	(1) 105538-01
9	Flue Collector Side Panel	1	(1) 105540-01
10	Flue Collector Center Panel	1	(1) 105537-01
11	Flue Collector Top Panel	1	(1) 105541-01
12	Condensate Pan	1	(1) 105260-01
13	Horz. Convection tube Access Door Clamp	2	(2) 105263-01
14	Horz. Furnace Tube Access Door Clamp	2	(2) 105262-01
15	Vert. Tube Access Door Clamp	3	(3) 105261-01
16	Bottom Reinforcement Plate	1	(1) 105281-01
17	Vertical Center Reinforcement Plate	1	(1) 105284-01
18	Vertical Side Reinforcement Plates	2	(2) 105283-01
19	Top Reinforcement Plate	1	(1) 105282-01
20	Boiler Base Frame	1	(1) T40010
21	Top Vestibule Panel	1	(1) 105343-01
22	Bottom Vestibule Panel	1	(1) 105343-02
23	E-Z Tab Stack Adapter	1	811EVC006
24	Center Panel Brace	1	(1) 105264-01
Not Shown	Black Impregnated Gasket 2-1/2" Wide (Tube Access Doors)	20.5 ft	(20.5 LF) 105668-02
Not Shown	Black Impregnated Gasket 1" Wide (Flue Collector)	37 ft	(37 LF) 102178-01

Appendix H.2 ARC1000 Burner Assembly

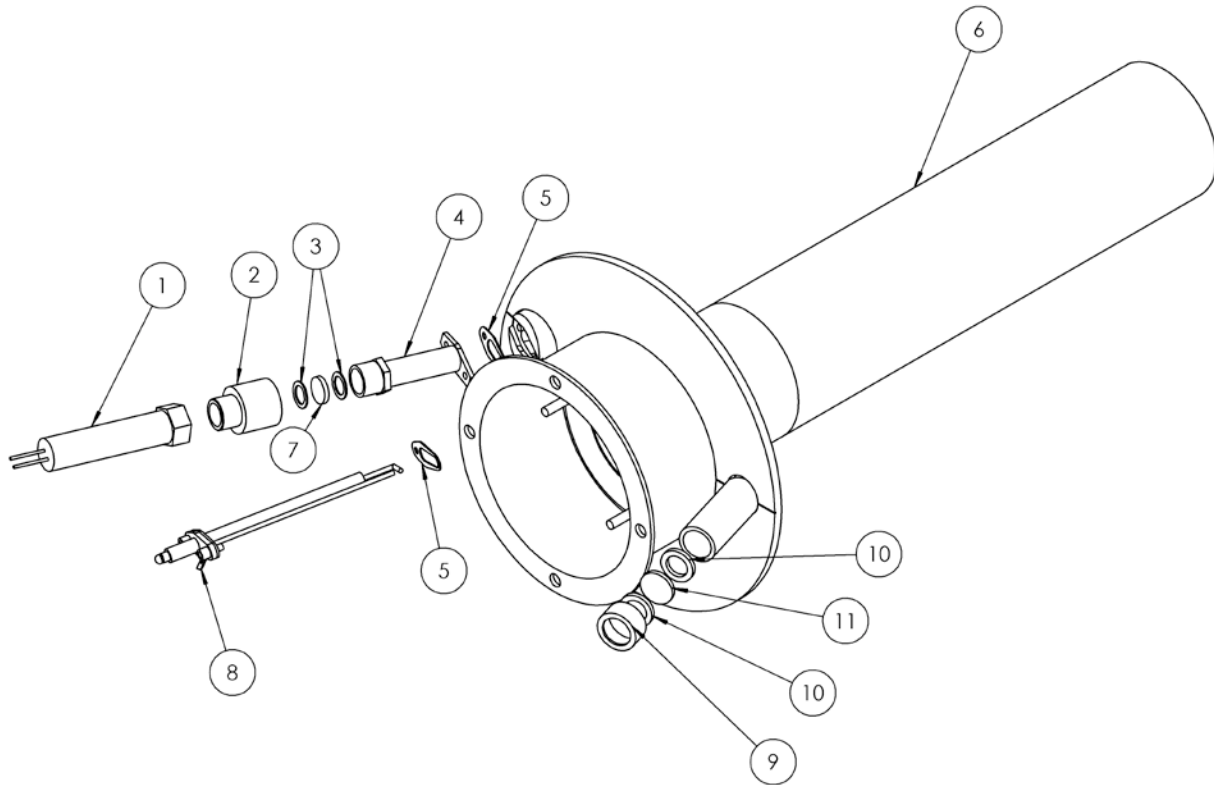

Table 21: Burner Assembly

Item Number	Description	Quantity	Part Number
1	Ultra-Violet (UV) Scanner	1	106684-01
2	Heat Insulator	1	8026217
3	Ultra-Violet (UV) Lens Gasket	2	107031-01
4	Ultra-Violet (UV) Scanner Bracket	1	106685-01
5	Igniter/Scanner Gasket	1	105246-02
6	Burner	1	105618-01
7	Ultra-Violet (UV) Lens	1	107032-01
8	Igniter	1	105678-01
9	Site Glass Bushing	1	105657-01
10	Site Glass Gasket	2	105490-01
11	Site Glass Lens	1	105656-01

Appendix H.3 Gas Train and Upper Vestibule Controls

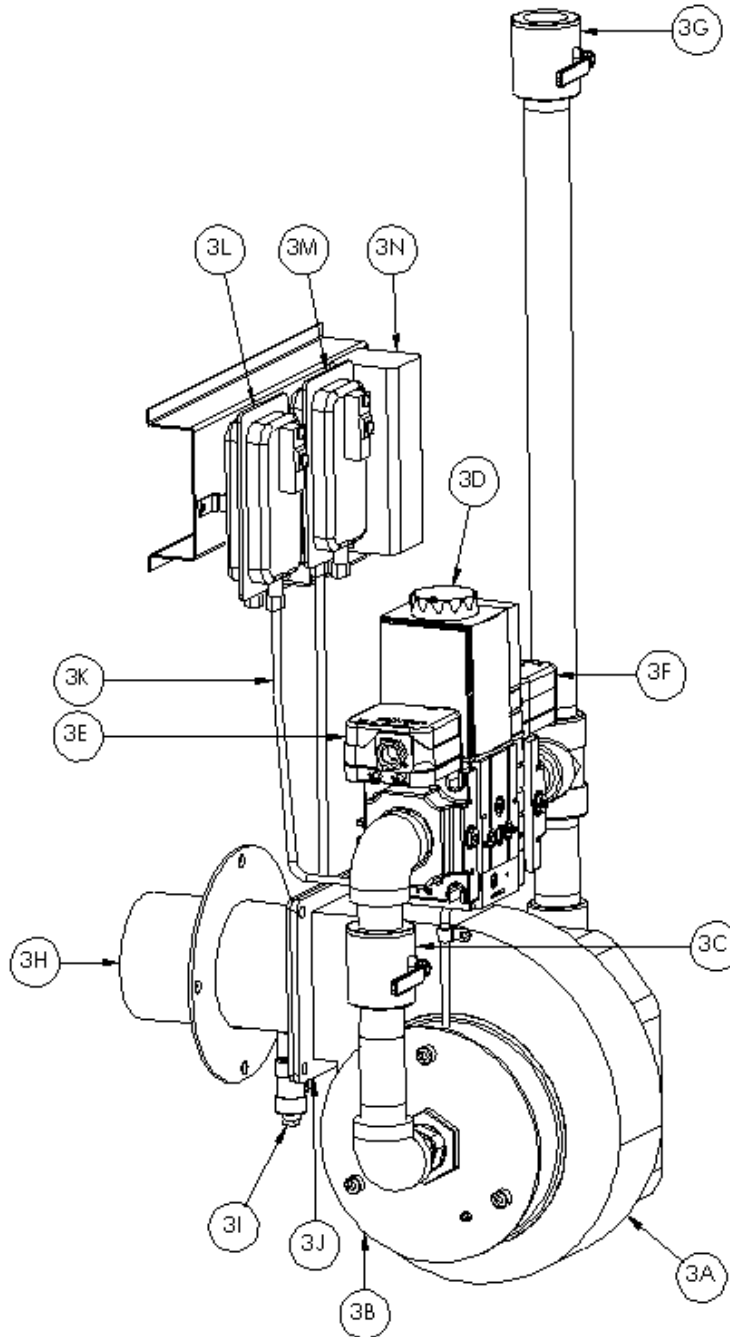

Table 22: Gas Train and Upper Vestibule Controls		
Key No.	Description	(Quantity) Part Number
3A	Blower	(1) 105326-01
3B	Swirl Plate	(1) 105327-01
3C	Manual Shut-Off Ball Valve	(1) 105325-01
3D	Main Gas Valve	(1) 105330-01
3E	High Gas Pressure Switch	(1) 105328-01
3F	Low Gas Pressure Switch	(1) 105329-01
3G	Ball Valve, 1-1/8" Tapping	(1) 105324-01
3H	Blower Adapter	(1) 105259-01
3I	1/4"NPT Plug	(2) 806603599
3J	1/4"NPTx1/4" Tube Compression Fitting	(2) 822658
3K	Pressure Switch Tubing	(3FT) 92465560
3L	Minimum Air Pressure Switch (Combustion Air)	(1) 106239-01
3M	Maximum Air Pressure Switch (Blocked Vent)	(1) 105691-01
3N	Auto-Reset High Limit	(1) 80160626

Appendix H.4 Jacket

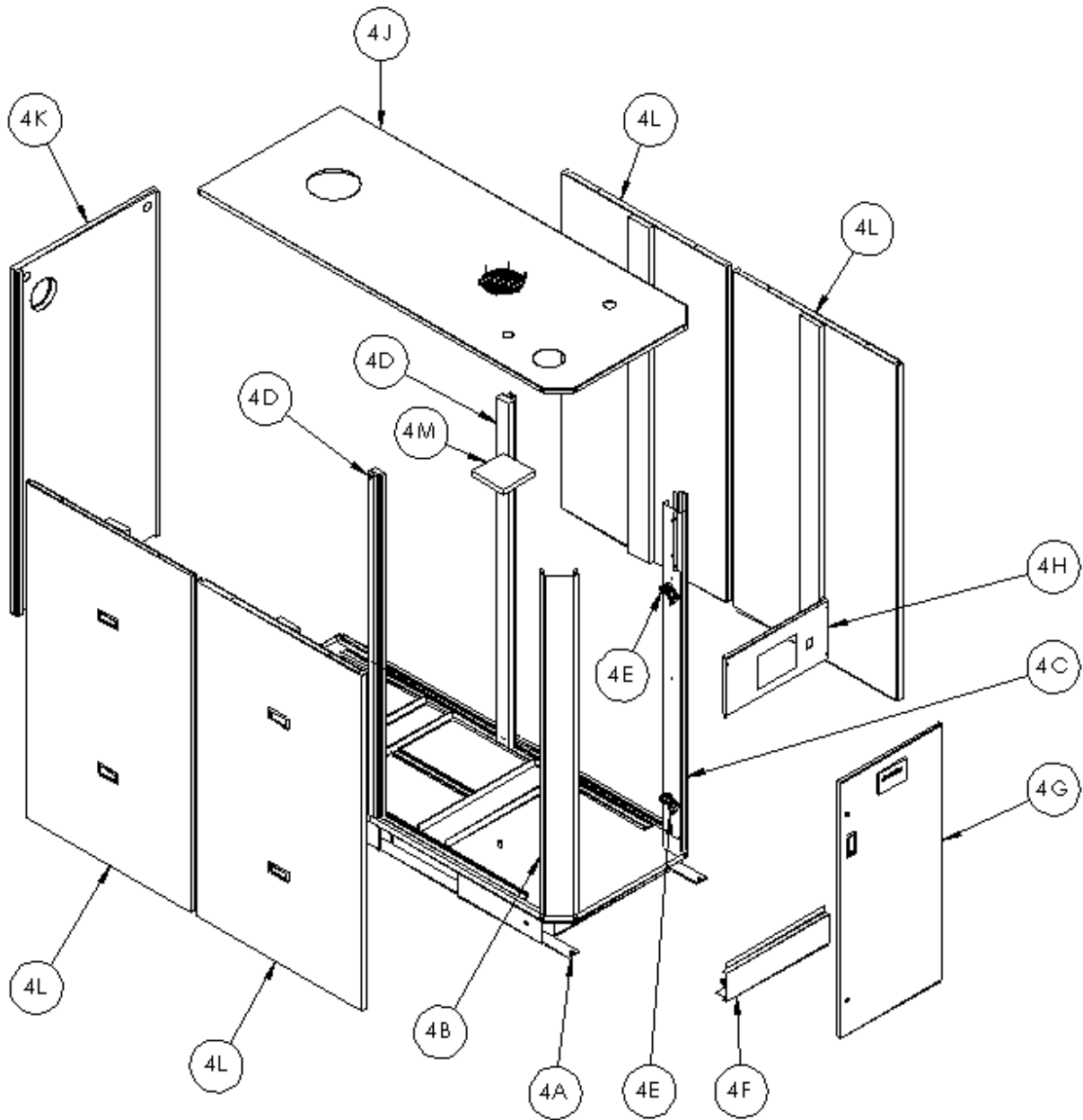

Table 23: Jacket		
Key No.	Description	(Quantity) Part Number
4A	Base	(1) 105124-01
4B	Front Left Corner	(1) 105172-01
4C	Front Right Corner	(1) 105172-04
4D	Center Rail	(1) 105176-01
4E	Hinges	(2) 105714-01
4F	Front Lower Panel	(1) 105177-01
4G	Front Door	(1) 105170-04
4H	Front Upper Panel	(1) 105169-01
4J	Top Panel	(1) 105174-04
4K	Rear Panel	(1) 105173-02
4L	Side Door	(1) 105178-02
4M	Air Intake Filter	(1) 811SOL0020
Not Shown	Black Strip Gasket	(67.5 LF) 105476-01

Appendix H.5 Outlet Manifold

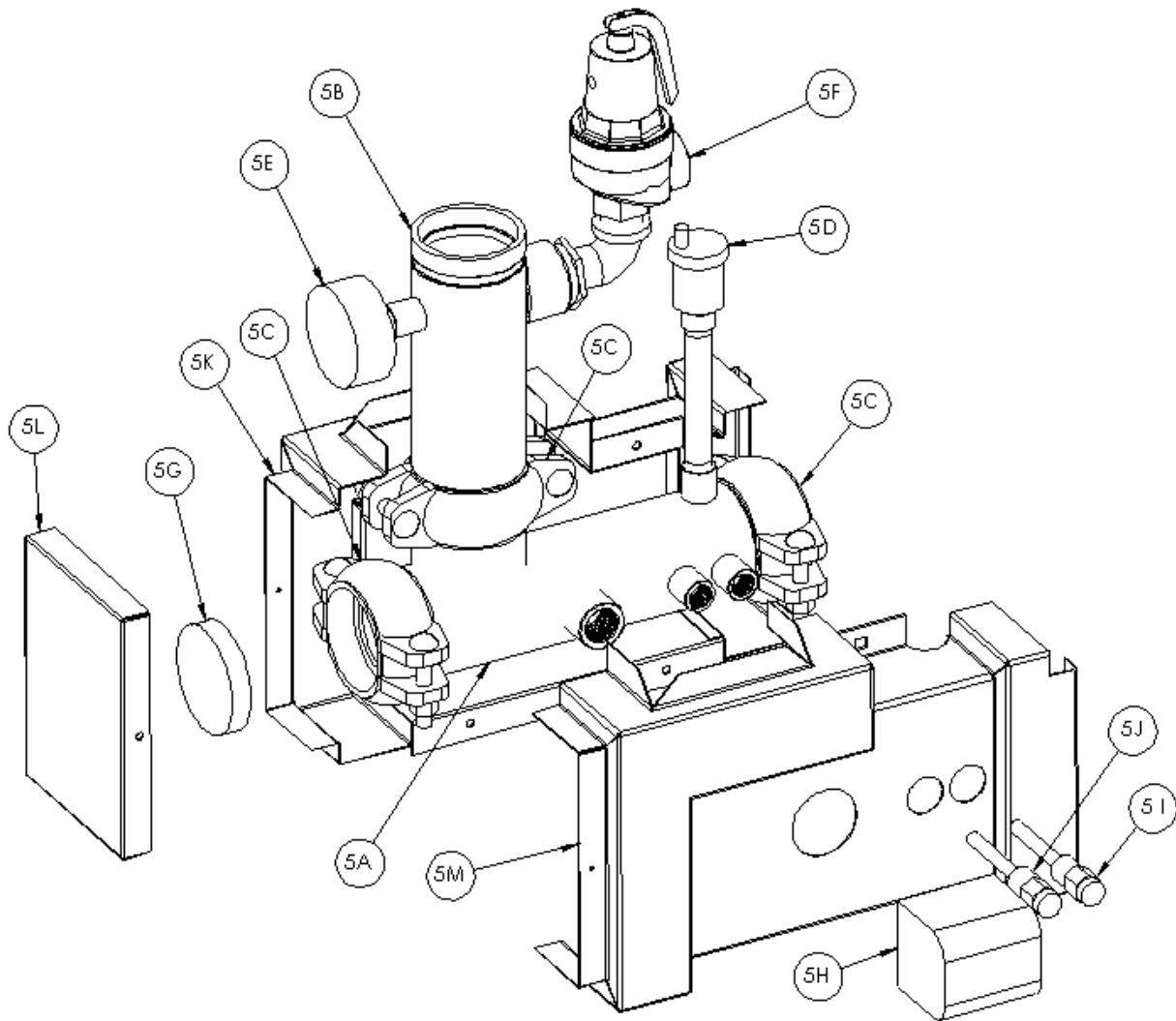

Table 24: Outlet Manifold								
Key No.	Description	(Quantity) Part Number						
		30 PSI RV Setting	50 PSI RV Setting	60 PSI RV Setting	75 PSI RV Setting	100 PSI RV Setting	125 PSI RV Setting	150 PSI RV Setting
5A	Upper Water Outlet Manifold	(1) 105381-01						
5B	Top Panel Water Outlet Manifold	(1) 105382-01						
5C	3" Victaulic Coupling	(3) 104035-02						
5D	1/2"NPT Air Vent	(1) 102260-01						
5E	Temperature/Pressure Gauge	(1) 103470-01			(1) 103470-02			(1) 103470-03
5F	Pressure Relief Valve	(1) 81660338	(1) 81660359	(1) 81660375	(1) 81660374	(1) 81660377	(1) 81660373	(1) 81660378
5G	3" Cap	(1) 104035-03						
5H	LWCO Probe	(1) 80160592						
5I	Immersion Well For Auto-Reset High Limit	(1) 105684-01						
5J	Brass Immersion Well, Outlet Water Sensor (10Kohm)	(1) 105684-01, (1) 105686-01						
5K	Manifold Cover Left Side Assy.	(1) 105480-02						
5L	Manifold Cover Cap Assy.	(1) 105480-03						
5M	Manifold Cover Right Side Assy.	(1) 105480-01						
N/A	Optional Remote Header sensor, Immersion Well	(1) 105685-01, 105684-01						

Appendix H.6 Miscellaneous External Components

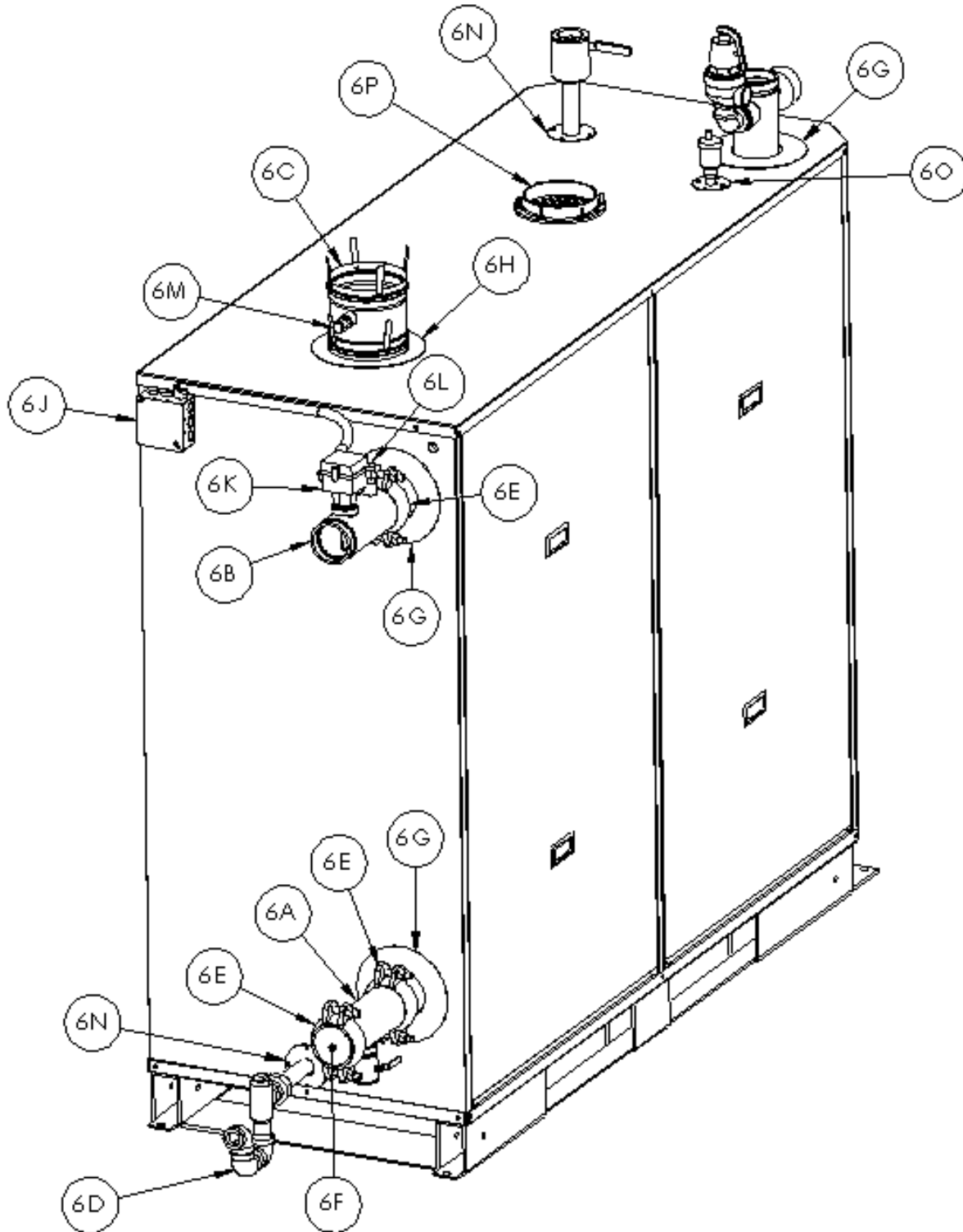

Table 25: Miscellaneous External Components

Key No.	Description	(Quantity) Part Number
6A	Lower Rear Manifold	(1) 105384-01
6B	Water Inlet Manifold	(1) 105383-01
6C	Exhaust Stack	(1) 105697-01
6D	Condensate Trap	(1) 105432-01
6E	3" Victaulic Coupling	(3) 104035-02
6F	3" Cap	(1) 104035-03
6G	Water Inlet/Outlet Manifold Trim Ring and Gasket	(3) 105211-02, (3) 8205644
6H	Vent Outlet Trim Ring and Gasket	(1) 105211-01, (1) 105486-01
6J	J-box and J-box Cover	(1) 8136056, (1) 8136027
6K	Water Flow Switch	(1) 105687-01
6L	Brass Immersion Well, Inlet Temperature Sensor 10Kohm	(1) 105684-01, (1) 105685-01
6M	St Steel Immersion Well, Stack Temperature Sensor	(1) 105683-01, (1) 105686-01
6N	1" Pipe Trim Ring and Gasket	(2) 105211-04, (2) 8205652
6O	Air Vent Trim Ring and Gasket	(1) 105211-05, (1) 105693-01
6P	Air Intake Ring and Gasket	(1) 81156106, (1) 82056106

Appendix H.7 Controls

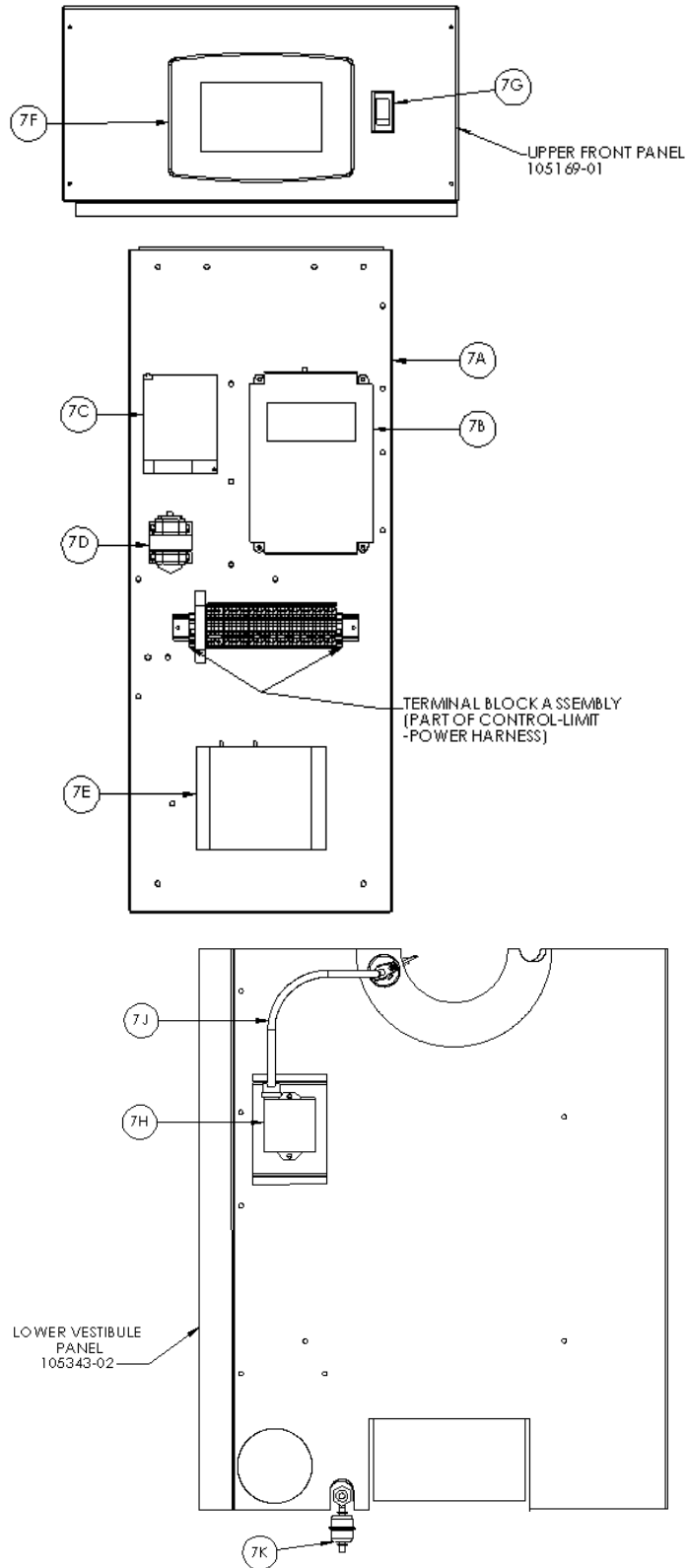

Table 26: Controls

Key No.	Description	(Quantity) Part Number
7A	Control Panel	(1) 105171-01
7B	Concert Boiler Control	(1) 105681-01
7C	24VDC Transformer	(1) 105680-01
7D	120/24V Step-down Transformer	(1) 801600502
7E	Low Water Cut-Off Reset Box	(1) 80160591
7F	Display	(1) 105682-01
7G	On/Off Switch	(1) 105658-01
7H	Ignition Transformer	(1) 80160208
7J	Ignition Cable	(1) 105218-01
7K	Blocked Condensate Switch	(1) 105659-01
Not Shown	Control-Limit-Power Harness	(1) 105660-01
Not Shown	Communication-Sensing Harness	(1) 105661-01
Not Shown	Line-Flow Harness	(1) 105662-01
Not Shown	Display Power Harness	(1) 105663-01

Thermal Solutions

("seller")

LIMITED WARRANTY

LIFETIME THERMAL SHOCK WARRANTY

Subject to the terms and conditions herein, Seller warrants to the original owner at the original installation site that the boiler pressure vessel is covered against failure due to "Thermal Shock" for the lifetime of the boiler as described below:

- This warranty is only valid if the boiler is installed and operated in accordance with our Installation and Operation Manual.
- This warranty shall cover leaks in pressure vessel (boiler tubes, upper and lower drums) when upon inspection by seller, such damage is attributed to unequal expansion, often described as "thermal shock."
- This warranty does not cover damages or failures that can be attributed to corrosion, scale, dirt or sludge accumulation in the boiler, low water conditions, failure of any safety devices or any other improper service, operation or neglect.

LIFETIME PRESSURE VESSEL WARRANTY

Subject to the terms and conditions herein, Seller warrants to the original owner at the original installation site that the boiler pressure vessel is covered against leaks (boiler tubes, upper and lower drums) for the lifetime of the boiler as described below:

- This warranty is only valid if the boiler is installed and operated in accordance with our Installation and Operation Manual.
- This warranty shall cover leaks in pressure vessel (as described above) when upon inspection by seller, such damage is attributed to unequal expansion, often described as "thermal shock."
- This warranty does not cover damages or failures that can be attributed to corrosion, scale, dirt or sludge accumulation in the boiler, low water conditions, failure of any safety devices or any other improper service, operation or neglect.

FLUE GAS CORROSION WARRANTY

Subject to the terms and conditions herein, Seller warrants to the original owner at the original installation site that the pressure vessel and flue collector are covered against failure due to fireside flue gas corrosion per the schedule as follows:

- A. Upper and Lower Pressure Vessel Headers - 10 years from date of shipment.
- B. Flexible Boiler Tubes - 5 years from date of shipment.
- C. Flue Collector Sides, Top and Bottom - 5 years from date of shipment.

BURNER HEAD WARRANTY

Subject to the terms and conditions herein, Seller warrants to the original owner at the original installation site that the burner head will be free from defects in materials and workmanship for a period of one year after the date of shipment.

LIMITED WARRANTY

Subject to the terms and conditions herein, Seller warrants to the original owner at the original installation site those products manufactured by Seller ("Products") comply, at the time of manufacture, with recognized hydronics industry regulatory agency standards and requirements then in effect and will be free from defects in materials and workmanship for a period of one year after the date of shipment.

REMEDY

- A. The sole remedy for breach of this warranty is expressly limited to the repair or replacement of any part found to be defective under conditions of normal use within the Warranty Period. Labor for removal and /or installation is not included.
- B. Warranty – The owner must notify the original installer of the Product and Seller (Attention: Thermal Solutions, P.O. Box 3244, Lancaster, PA 17604-3244), in writing, within the Warranty Period, providing a detailed description of all claimed defects. Transportation to a factory or other designated facility for repairs of any products or items alleged defective shall, in all events, be the responsibility and at the cost of the owner.

Exclusions

Seller shall have no liability for and this warranty does not cover:

- A. Incidental, special or consequential damages, such as loss of the use of products, facilities or production,

inconvenience, loss of time or labor expense involved in repairing or replacing the alleged defective Product.

B. The performance of any Product under conditions varying materially from those under which such Product is usually tested under industry standards as of the time of shipment

C. Any damage to the Product due to abrasion, erosion, corrosion, deterioration, abnormal temperatures or the influence of foreign matter or energy.

D. The design or operation of owner's plant or equipment or of any facility or system of which any Product may be made a part.

E. The suitability of any Product for any particular application.

F. Any failure resulting from misuse, modification not authorized by Seller in writing, improper installation or lack of or improper maintenance.

G. Equipment furnished by the owner, either mounted or un-mounted, or when contracted for by the owner to be installed or handled.

H. Leakage or other malfunction caused by:

1. Defective installations in general and specifically, any installation, which is made:
 - a. In violation of applicable state or local plumbing housing or building codes,
 - b. Without a certified ASME, pressure relief valve, or
 - c. Contrary to the written instructions furnished with the unit.
2. Adverse local conditions in general and, specifically, sediment or lime precipitation in the tubes and/or headers or corrosive elements in the atmosphere.
3. Misuse in general and, specifically, operation and maintenance contrary to the written instructions furnished with the unit, disconnection, alteration or addition of

components or apparatus, not approved by Seller, operation with fuels or settings other than those set forth on the rating plate or accidental or exterior damage.

I. Production of noise, orders, discoloration or rusty water.

J. Damage to surrounding area or property caused by leakage or malfunction.

K. Costs associated with the replacement and/or repair of the unit including: any freight, shipping or delivery charges, and removal, installation or reinstallation charges, any material and/or permits required for installation, reinstallation or repair, charges to return the boiler and or components.

Seller's liability under this warranty shall not in any case exceed the amount paid for the Product found to be defective.

Third-Party Warranties

For goods or components not manufactured by Seller, the warranty obligations of Seller shall, in all respects, conform and be limited to one year from the date of shipment.

Severability

To the extent that any provisions shall of this warranty would be void or prohibited under applicable law, such provisions shall be limited in effect to the minimum extent necessary to render the remaining provisions hereof enforceable.